

# INSTRUCTION MANUAL

Serial Number \_\_\_\_\_

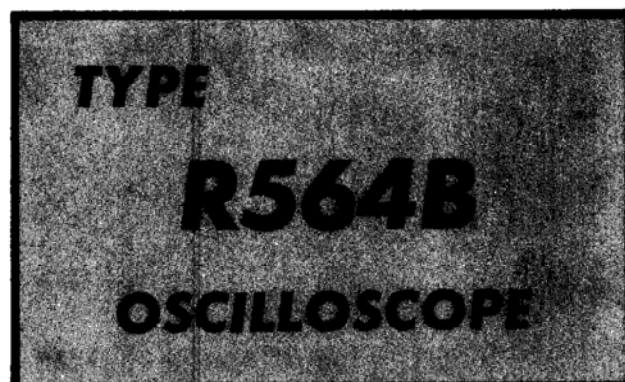

*Tektronix, Inc.*

S.W. Millikan Way • P. O. Box 500 • Beaverton, Oregon 97005 • Phone 644-0161 • Cables: Tektronix  
070-0805-00



## WARRANTY

All Tektronix instruments are warranted against defective materials and workmanship for one year. Tektronix transformers, manufactured in our plant, are warranted for the life of the instrument.

Any questions with respect to the warranty mentioned above should be taken up with your Tektronix Field Engineer.

Tektronix repair and replacement-part service is geared directly to the field, therefore all requests for repairs and replacement parts should be directed to the Tektronix Field Office or representative in your area. This procedure will assure you the fastest possible service. Please include the instrument Type and Serial or Model Number with all requests for parts or service.

Specifications and price change privileges reserved.

Copyright © 1968 by Tektronix, Inc., Beaverton, Oregon. Printed in the United States of America. All rights reserved. Contents of this publication may not be reproduced in any form without permission of the copyright owner.

# CONTENTS

- Section 1 Specification
- Section 2 Operating Instructions
- Section 3 Circuit Description
- Section 4 Maintenance
- Section 5 Performance Check/Calibration
- Abbreviations and Symbols
- Parts Ordering Information
- Section 6 Electrical Parts List
- Section 7 Mechanical Parts List Information
- Section 8 Mechanical Parts List
- Diagrams
- Section 9 Mechanical Parts List Illustrations
- Accessories
- Rackmounting

Abbreviations and symbols used in this manual are based on or taken directly from IEEE Standard 260 "Standard Symbols for Units", MIL-STD-12B and other standards of the electronics industry. Change information, if any, is located at the rear of this manual.

SEE PARTS LIST FOR SEMICONDUCTOR TYPES

SER/PS M MODEL 112.3

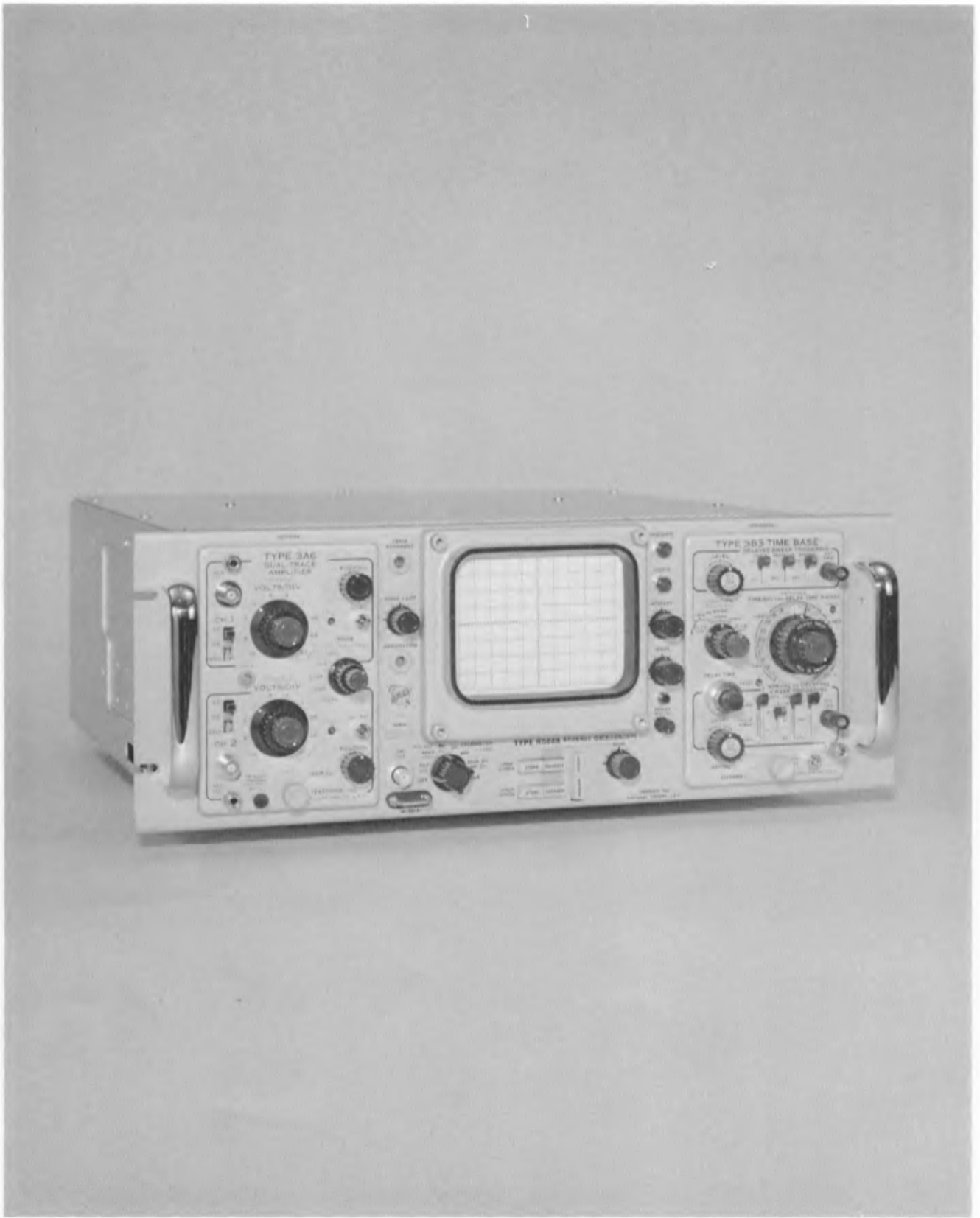

Fig. 1-1. Type R564B Oscilloscope.

# SECTION 1

## TYPE R564B SPECIFICATION

Change information, if any, affecting this section will be found at the rear of the manual.

### Introduction

The Type R564B Storage Oscilloscope is designed to store cathode-ray tube displays for viewing or photographing up to an hour after application of the input signal. In addition, the instrument can be operated as a conventional oscilloscope. The Type R564B is compatible with Tektronix 2-Series and 3-Series plug-in units (see following table and Section 2 for exceptions), thus it can be used in a variety of applications including differential, multi-trace, wide-band, delayed sweep, sampling and spectrum analysis.

The cathode-ray tube used in the Type R564B is a direct view, bistable storage tube having an 8 X 10 centimeter display area, divided into two 4 X 10 cm storage screens. The storage screens are independently controlled for split screen applications. An additional area which does not store is provided to the left of the targets to function as a locate zone in the single-sweep store mode.

This instrument will perform to the specifications listed in this section in a laboratory environment with ambient temperature range between 0° C and +50° C, except as indicated. Warmup time for rated accuracies is 5 minutes (certain plug-ins may require additional warmup time). The Performance Check instructions outlined in Section 5 provide a convenient method of checking the performance of this instrument.

### ELECTRICAL CHARACTERISTICS

#### CRT

Characteristic	Performance
Plug-in compatibility	2- and 3-Series plug-ins, except the 3S6, 3T6; 3B5 (horizontal only)
CRT Type	Electrostatic deflection
Graticule Area	8 X 10 cm
Phosphor	Storage (similar to P1)
Typical CRT Accelerating Voltage	3.5 kV

#### Storage Display

	T5641-200	T5641-201
Writing Speed		
Basic (Initial)	At least 25 cm/ms	At least 100 cm/ms
Enhanced	At least 250 cm/ms	At least 500 cm/ms
Luminance		
Initial	At least 6 fL	At least 2 fL
Constrast Ratio		
Initial	2:1	2:1

Storage Time (Recommended)	One hour or less
Erase Time	250 ms or less
Locate	Displaces dot to preview area (left of graticule) and at the vertical position of the next sweep when sweep start is positioned to first graticule line

#### External Outputs

Calibrator	
Output Voltage	
Into High Impedance (1 M $\Omega$ or greater)	+4 mV, +40 mV, +0.4 V, +4 V, +40 V (ground to peak) square wave and 40 VDC; (within 1½%, +20° C to +30° C; within 2%, 0° C to +50° C)
Into 50.0 $\Omega$	+2 mV, +20 mV, +0.2 V (ground to peak) square wave; (within 1½%, +20° C to +30° C; within 2%, 0° C to +50° C)
Current Loop	10 mA DC or 10 mA (P-P) square wave (within 1½%, +20° C to +30° C; within 2%, 0° C to +50° C)
Frequency	1 kHz, within 1%
Duty Factor	48% to 52%
Risetime and Fall-time	1 $\mu$ s or less at all voltages with load capacitance of 100 pF or less, except 40 V. 2.5 $\mu$ s or less at 40 V with load capacitance of 100 pF or less

#### External Inputs

CRT Cathode (AC Coupled)	
Low -3 dB Frequency	1.8 kHz or less
Z Axis Modulation	10 V or less (P-P) gives useful intensity variation
Maximum Input Voltage	150 V
Remote (Storage) Control Input	
Half Screen Erase	
Pulse Initiated Erase	Negative pulse of 5 V to 100 V. Rate of change at least 0.1 V/ $\mu$ s
Impedance Change Initiated Erase	From 1 M $\Omega$ to 50 k $\Omega$ in 10 $\mu$ s or less

**Specification—Type R564B**

**Power Supply**

Line Voltage Ranges	115 VAC	230 VAC	
	Low	90 V to 110 V	180 V to 220 V
	Medium	104 V to 126 V	208 V to 252 V
	High	112 V to 136 V	224 V to 272 V
Line Frequency Range	48 to 66 Hz		
Maximum Power Consumption at 115 V, 60 Hz	204 W, 2.18 A		

**ENVIRONMENTAL CHARACTERISTICS**

Characteristic	Performance
Temperature	
Non-operating	-40° C to +65° C
Operating	0° C to +50° C

Altitude	
Non-operating	To 50,000 feet
Operating	To 15,000 feet

**PHYSICAL**

Finish	Lacquered aluminum panels. Anodized aluminum front panel.
Dimensions	
Height	≈ 7 inches
Width	≈ 19 inches
Length	≈ 20½ inches

**Accessories**

Standard accessories supplied with the Type R564B are listed on the last pullout page of the Mechanical Parts List illustrations. For optional accessories available for use with this instrument, see the current Tektronix, Inc. catalog.

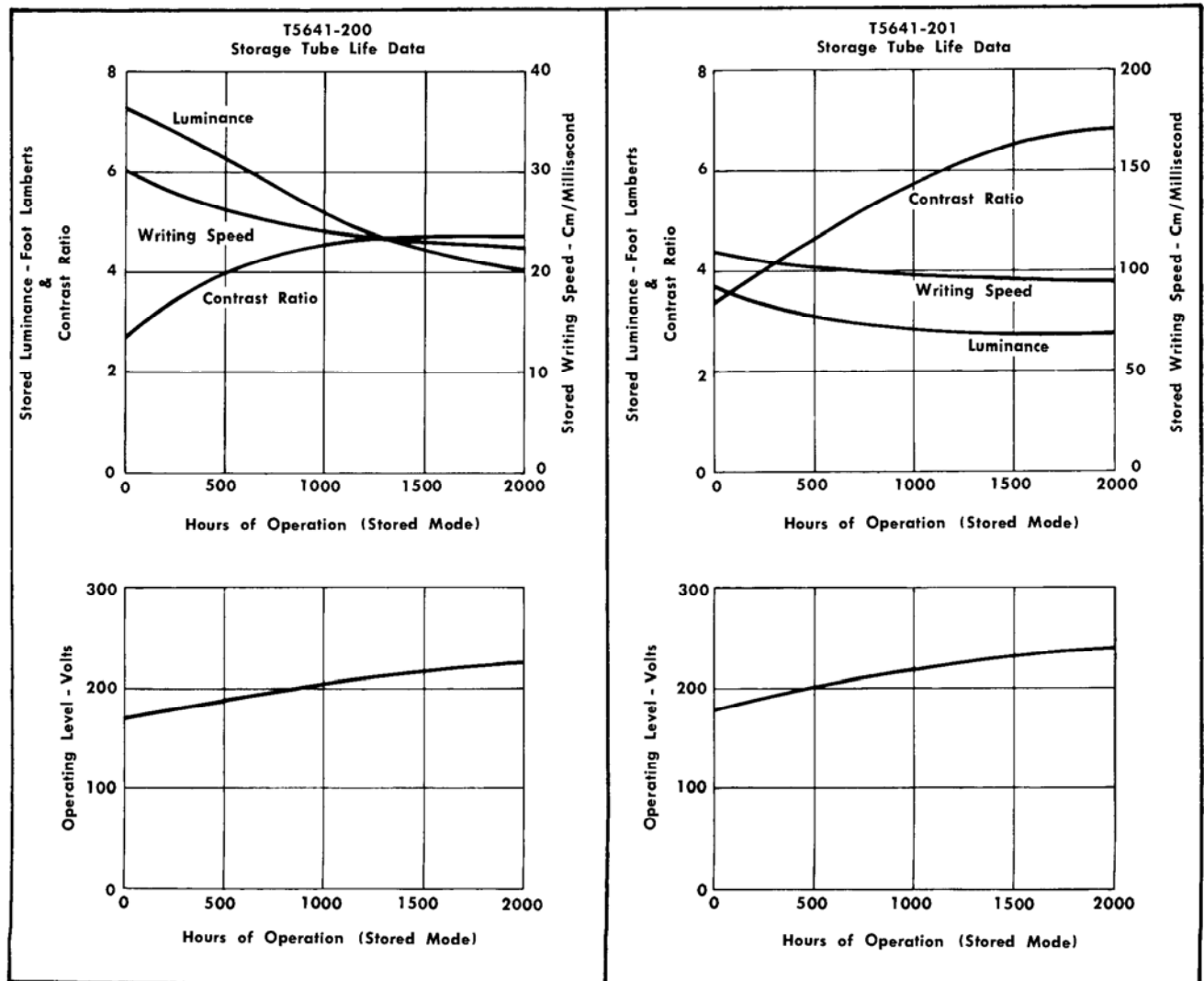

Fig. 1-2. Life data graphs of T5641-200 and T5641-201 storage tubes.

## SECTION 2

# OPERATING INSTRUCTIONS

Change information, if any, affecting this section will be found at the rear of the manual.

### Introduction

To effectively use the Type R564B, the operation and capabilities of the instrument must be understood. This section of the manual describes the operation of the front- and rear-panel controls and connectors, and gives the first time and general operating information.

### Rackmounting

Complete information for rackmounting installation of the Type R564B is given on the Rackmounting fold-out pages at the rear of this manual.

### Line Voltage

The Type R564B can be operated from either a 115-volt or a 230-volt nominal line-voltage source. The Line Voltage Selector assembly on the rear panel converts the instrument from one operating range to the other. In addition, this assembly changes the primary connections of the power transformer to allow selection of one of three regulating ranges. The assembly includes two fuses to provide the correct protection for the instrument; both fuses are connected for 230-volt nominal operation, and only one fuse is connected for 115-volt nominal operation. Use the following procedure to obtain the proper line voltage and regulating range settings of the Line Voltage Selector:

1. Disconnect the instrument from the power source.
2. Loosen the two captive screws which hold the cover onto the voltage selector assembly; then pull to remove the cover.

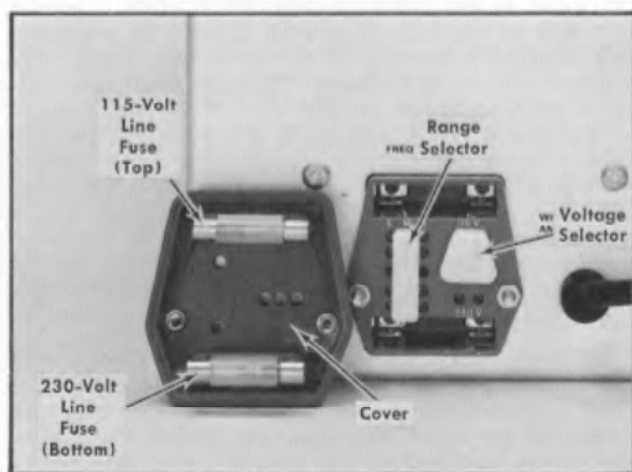

Fig. 2-1. Line Voltage Selector assembly on the rear panel (shown with cover removed).

3. To convert from 115 volts nominal to 230 volts nominal line voltage, pull out the Voltage Selector switch bar (see Fig. 2-1); turn it around 180° and plug it back into the remaining holes. Change the line-cord power plug to match the power-source receptacle or use a 115- to 230-volt adapter.

4. To change regulating ranges, pull out the Range Selector switch bar (see Fig. 2-1); slide it to the desired position and plug it back in. Select a range centered about the average line voltage to which the instrument is to be connected (see Table 2-1).

5. Re-install the cover and tighten the two captive screws.

6. Before applying power to the instrument, check that the indicating tabs on the switch bars are protruding through the correct holes for the desired nominal line voltage and regulating range.

### CAUTION

Damage to the instrument may result from incorrect Line Voltage Selector settings.

**TABLE 2-1**  
Regulating Ranges

Range Selector Switch Position	Regulating Range	
	115-Volts Nominal	230-Volts Nominal
LO (switch bar in left holes)	90 to 110 volts	180 to 220 volts
M (switch bar in middle holes)	104 to 126 volts	208 to 252 volts
HI (switch bar in right holes)	112 to 136 volts	224 to 272 volts

### Operating Temperature

The Type R564B can be operated where the ambient air temperature is between 0° C and +50° C. The instrument can be stored in ambient temperatures between -40° C and +65° C. After storage at a temperature beyond the operating limits, allow the chassis temperature to come within the operating limits before power is applied.

A fan at the rear of the Type R564B provides forced-air cooling of the instrument. For proper circulation of air, the instrument should normally be operated with the top and bottom covers in place. Do not block or restrict the air flow through the instrument.

A thermal cutout in this instrument provides thermal protection and disconnects the power to the instrument if the

## Operating Instructions—Type R564B

internal temperature exceeds a safe operating level. This device will automatically re-apply power when the temperature returns to a safe level.

### SELECTION OF PLUG-IN UNITS

#### General Information

The Type R564B is designed to use Tektronix 2-series and 3-series amplifier and time-base plug-in units for amplifying the vertical input signal and producing the time-base sweep. The use of plug-in units permits the selection of display modes, bandwidth, sensitivity and number of inputs so that the oscilloscope performance can be changed to meet changing measurement needs.

#### NOTE

Programmable plug-in Types 3S6 and 3T6 are not compatible with the Type R564B; however, the capability of these plug-ins is available (without programmability) with Types 3S5 and 3T5. Use the 3B5 in the right-hand (horizontal) compartment only. Refer to the instruction manual of the plug-in unit for specific information.

To install a plug-in unit in the Type R564B, push it all the way into the plug-in compartment, then turn the locking knob (at the bottom of the front panel) clockwise until it is tight. To remove the unit, turn the knob counterclockwise until the latch releases, then pull the unit out.

The accuracy of measurements made with the Type R564B depends on the calibration of the plug-in units used. Since the plug-in units drive the deflection plates directly, each unit must be adjusted to match the deflection sensitivity of the particular CRT it drives. Therefore, the gain or sweep timing adjustment must be checked each time a plug-in unit is changed. On most units, gain or timing calibration is made with a front-panel screwdriver adjustment. (Sampling units require special adjustment procedures.) Refer to the plug-in unit instruction manual for the required procedure. Since the various plug-in units present different output voltage levels to the deflection plates, the FOCUS and ASTIGMATISM controls will also require readjustment.

Plug-in units can be changed without turning off the instrument power, but it is recommended that the power be turned off while the change is made. When the deflection and blanking voltage from the plug-in unit are disconnected from the oscilloscope (and during plug-in unit warmup), the spot that appears on the CRT screen may burn the storage target, even at normal intensity.

#### CAUTION

Always turn the INTENSITY control fully counterclockwise while exchanging a plug-in unit, whether the power is left on or turned off. Increase the intensity only after the plug-in unit has had about ½ minute to warm up.

Either or both of the plug-in units can be operated on special extension cables for troubleshooting. For normal operation, however, the units must be installed in the oscilloscope. If the instrument is operated with the plug-in units

on extension cables, the high-frequency response and fast sweep rates will be affected.

#### Display Combinations

The plug-in unit in the left plug-in compartment controls the vertical (Y-axis) deflection of the CRT beam and the unit in the right plug-in compartment controls the horizontal (X-axis) deflection. The following paragraphs discuss some of the display combinations that can be obtained.

**Time-Base Displays.** To produce a conventional time-base, or Y-T display, an amplifier plug-in unit is used in the vertical (left) plug-in compartment and a time-base plug-in unit is used in the horizontal (right) plug-in compartment.

If a vertical sweep is desired with the input signal displayed horizontally, the time-base unit is inserted in the left compartment and the amplifier unit in the right compartment. However, if a vertical sweep is used, there is no retrace blanking, no chopped blanking for multi-trace displays, the delaying-sweep intensification does not operate and the LOCATE pushbutton serves no useful function because these circuits are associated with the horizontal (right) plug-in compartment.

**X-Y Displays.** Two amplifier units may be used to produce either a single or a multiple X-Y display (for example, for phase comparison measurement). Plug-in units with equal phase shift will produce an accurate X-Y display; however, for high frequency X-Y operation, use of two units of the same type is recommended. Careful factory adjustment of deflection-circuit capacitance to a standard value in the Type R564B minimizes high-frequency phase-shift between two plug-in units of the same type. For multiple X-Y displays, both synchronization and automatic pairings are provided for some amplifier units. Refer to the instruction manual of the plug-in unit to be used.

**Multi-Trace Displays.** The use of a dual-trace or multi-trace amplifier unit permits almost simultaneous viewing of two or more signals. For a multi-trace amplifier unit with single-channel trigger capability ("Channel 1 Trigger"), the trigger signal is applied through the Type R564B to the trigger circuit in the time-base unit. This permits triggering from a single input signal and the CRT display shows the time relationship between the various signals. When using a plug-in without single-channel triggering, an external trigger is recommended to establish time relationship in multi-trace displays. In chopped mode, the multi-trace blanking pulses from the amplifier unit are applied internally through the Type R564B to the CRT cathode, to blank the CRT beam while it is switched from one channel to another. This is accomplished with the amplifier unit in the left compartment, the time-base unit in the right compartment, and the rear panel CRT CATHODE SELECTOR switch in the CHOPPED BLANKING position.

**Delayed Sweep.** A delayed-sweep time-base unit is convenient for detailed viewing of pulse-train segments that occur a relatively long time after the maximum-amplitude (triggering) portion of the signal. The portion of the pulse train to be displayed by the delayed sweep may be intensified on the delaying-sweep display. A delayed-sweep unit that has a calibrated time delay can also be used for making very accurate (within 1%) time measurements.



**Raster Generation.** A raster display can be presented by using two time-base units, one in each compartment. Intensity modulation can be achieved through the Z-axis of the CRT by applying the signal to the EXT INPUT connector on the rear panel and setting the CRT CATHODE SELECTOR to the EXT INPUT position.

**Sampling.** The apparent bandwidth of the oscilloscope can be increased to as much as one gigahertz through the use of sampling plug-in units. A sampling time-base unit must be used with a sampling amplifier unit in the Type R564B in order to produce the sampling display (even for X-Y operation). Generally, sampling and conventional plug-in units cannot be used together in the oscilloscope. However, Types 3S1 and 3S2 sampling amplifiers do have limited compatibility with conventional time-base units and the Type 3T5 sampling time-base unit can generate a real-time staircase sweep usable with conventional amplifiers.

**Spectrum Analysis.** Spectrum analyzer plug-in units can be used in conjunction with conventional time-base units to produce a spectral display (a graph of the relative amplitude distribution as a function of frequency).

**Custom Plug-In Units**

Blank-chassis plug-in units can be purchased through your local Tektronix Field Office as Modification Kit number 040-0245-00. These blank chassis permit one to build his own plug-in circuitry for use in the Type R564B.

**Heat dissipation and power consumption.** The power dissipated by the custom plug-in unit should not exceed 40 watts DC. The maximum total power that can be dissipated is 52 watts AC and DC. Maximum plug-in unit load is normally 75 mA on the +300-volt supply, 75 mA on the +125-volt supply, 750 mA on the -12.2-volt supply and 65 mA on the -100-volt supply.

**FUNCTION OF CONTROLS AND CONNECTORS**

A brief description of the function or operation of the front- and rear-panel controls and connectors follows. See Fig. 2-2 for locations.

**Front Panel**

ASTIGMATISM (Screwdriver Adjustment)	Used in conjunction with FOCUS control to obtain a well-defined display.
FOCUS Control	Used to optimize focus.
INTENSITY Control	Controls display brightness.
TRACE ALIGNMENT (Screwdriver Adjustment)	Permits alignment of the trace with respect to the horizontal graticule lines.
STORE Pushbuttons (Both Upper and Lower Screen)	When pushed in, the CRT is shifted to the storage mode; the button is released when pushed again, permitting conventional (non-store) operation.
ENHANCE Pushbuttons (Both Upper and Lower Screen)	When pushed in, permits increasing (with the LEVEL control) the writing speed capability for

ERASE Pushbutton (Both Upper and Lower Screen)	Provides a manual method of erasing a stored display; spring-loaded momentary-contact action.
LEVEL Control	Provides a selectable increase in writing speed capability for single-shot displays. Effective only when either or both ENHANCE pushbuttons are depressed.
INTEGRATE Pushbutton	Permits storage of very fast repetitive signals, by allowing the writing-gun beam to accumulate charges on the target while the flood-gun beams are turned off.
LOCATE Pushbutton	Displays a dot or vertical line in the non-storing area at left edge of screen to locate vertical position of signal while sweep is held off, provided that the sweep start has been positioned to left edge of the graticule. This permits display to be positioned before storing.
SCALE ILLUM Control	Varies illumination of the graticule grid lines.
POWER Switch	Used to apply or remove instrument input power.
POWER Indicator	Lamp bulb to indicate that AC power is applied to the instrument.
CALIBRATOR Switch	Provides selection of one of several values of square wave voltage or a calibrated DC voltage. A calibrated DC or square wave current can also be selected.
CAL OUT Connector	BNC connector at which calibrator output voltage is available.
10 mA Current Loop	Convenient means for calibrating current probes.

**Rear Panel**

CRT CATHODE SELECTOR Switch	Permits selection of normal CRT operation, chopped blanking (blanking of the between-channel switching transients when using multi-channel plug-in units in the chopped mode) and external CRT cathode input (permitting intensity modulation of the CRT by an external signal).
EXT INPUT Connector	BNC connector by which an external signal can be applied to the CRT cathode.

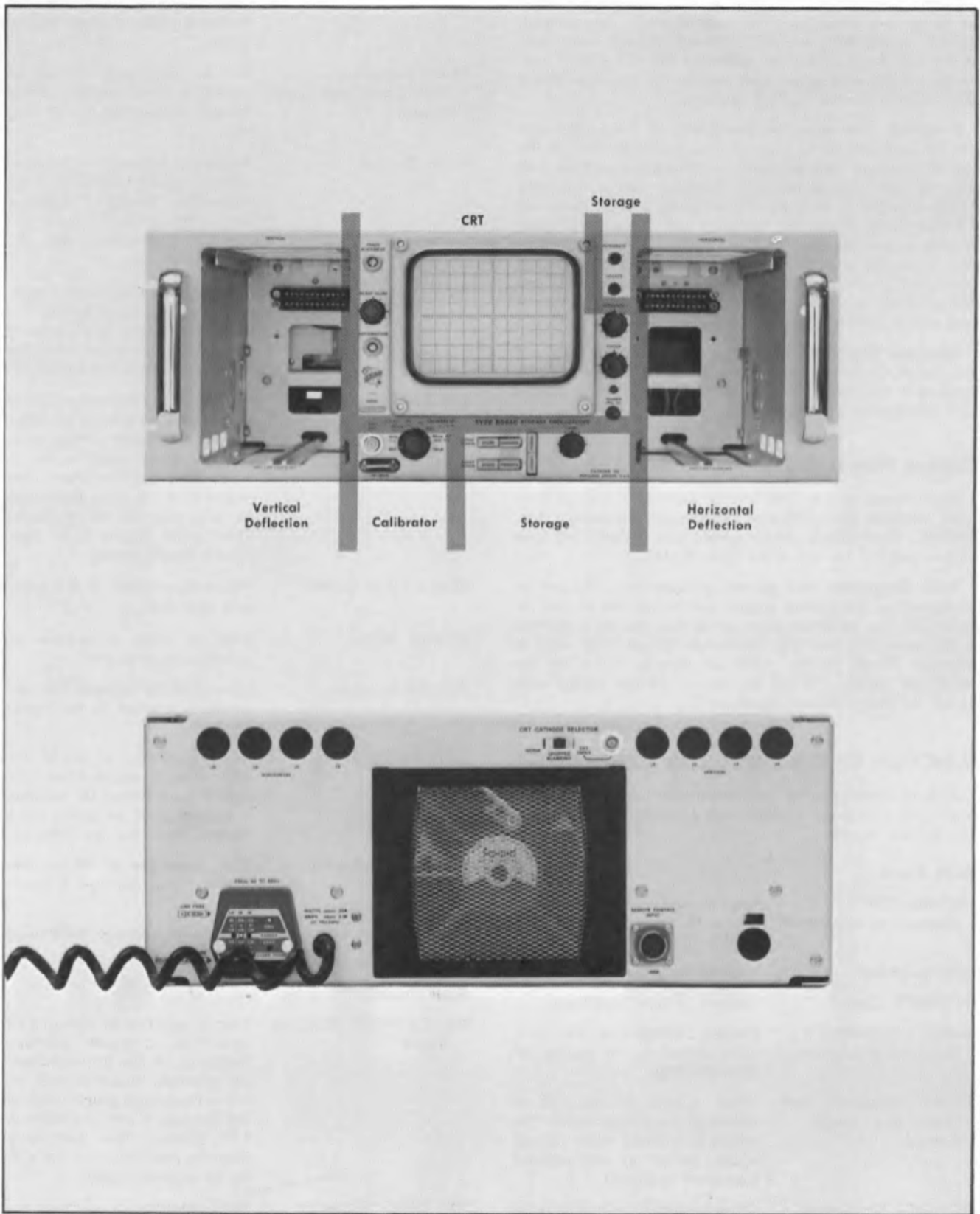

Fig. 2-2. Front- and rear-panel controls and connectors.

REMOTE CONTROL INPUT Connector	Permits remote erasure of each target.
Line Voltage Selector	Provides quick method of changing transformer taps to allow instrument to operate over a wide range of line voltages.
Horizontal and Vertical Connector Holes	Permit installation of auxiliary inputs and outputs through rear panel.

Time/Div	.5 ms
Variable (Time/Div)	Calibrated
Magnifier	Off
Sweep Mode	Normal
Normal-Single Sweep	Normal
Level	Free Run (clockwise)
Triggering Source	Internal
Slope	+
Coupling	Auto

### FIRST TIME OPERATION

The following procedure, using normal single-channel time-base mode, will demonstrate the basic operation of this instrument and its plug-in units.

1. Install a 2-Series or 3-Series amplifier plug-in unit in the vertical (left) plug-in compartment and a 2-Series or 3-Series time-base plug-in unit in the horizontal (right) plug-in compartment. Lock the plug-in units in place with their locking screws.

2. Set the POWER switch to the off position (pushed in).

3. Connect the power cord from the Type R564B to the proper line voltage.

#### NOTE

The LINE VOLTAGE SELECTOR assembly on the rear panel should be checked to be sure the Voltage Selector and Range Selector switch bars are in the proper positions for the line voltage applied.

4. Set the instrument controls as follows:

#### Type R564B

INTENSITY	Counterclockwise
FOCUS	Centered
SCALE ILLUM	Counterclockwise
ASTIGMATISM (screwdriver adjustment)	Centered
CALIBRATOR	4 V
STORE (both)	Non-store (out)
ENHANCE (both)	Off (out)
LEVEL	Counterclockwise
CRT CATHODE SELECTOR (rear panel)	NORM

#### Amplifier Unit (For example, Type 3A6)

Position	Centered
Mode	Normal (Channel 1)
Volts/Div	2
Variable (Volts/Div)	Calibrated
Input Coupling	DC

#### Time-Base Unit (For example, Type 3B3)

Position	Centered
----------	----------

5. Connect a patch cord from the CAL OUT connector to the Channel 1 input connector of the amplifier plug-in unit.

6. Set the POWER switch to ON (pulled out) and allow a few minutes for warmup.

7. Adjust the INTENSITY control to obtain a display of moderate brightness. The amplifier unit Position control may have to be adjusted to position the free running trace on the CRT screen. Do not turn the intensity higher than is necessary for adequate observation of the display.

8. Trigger the display by adjusting the time-base Level control.

9. Set the SCALE ILLUM control so the graticule illumination is approximately equal to the intensity of the display.

10. Adjust the time-base Position control to position the start of the trace at the left edge of the graticule.

11. Adjust the FOCUS and ASTIGMATISM controls for a sharp, well-defined display over the entire trace length. (If a focused display cannot be obtained, see Astigmatism Adjustment later in this section under General Operating Information.)

12. Adjust the TRACE ALIGNMENT screwdriver adjustment to align the display with the graticule lines.

13. Check the gain and DC balance of the amplifier unit and the timing adjustment (Sweep Cal) of the time-base unit as given in the instruction manuals for those units before making any voltage or time measurements. (In this demonstration, the calibrator waveform should be displayed as two divisions per cycle and two divisions in amplitude.)

### STORAGE OPERATION

In the storage mode, the writing-gun and deflection circuits operate the same as in the non-store mode. However, the storage circuits and storage controls are unique and require operating information not given in the plug-in unit manuals. The following demonstrations are intended to illustrate the various types of stored displays that are possible and the techniques required to obtain them.

#### Slow and Medium Sweep Rates

**Repetitive-Sweep Storage.** This method of storage is used for repetitive waveforms that produce normally bright displays on the CRT screen.

1. Set up a calibrator waveform display as described in "First Time Operation."

## Operating Instructions—Type R564B

2. Center the waveform display vertically on the CRT screen so that part of the waveform is above horizontal centerline and part of it is below the centerline.

3. Turn the INTENSITY control fully counterclockwise.

4. Press in both STORE buttons. The normal storage-mode background light level will be present on the storage screens.

5. Advance the INTENSITY control slowly in the clockwise direction to produce a waveform display of normal intensity, then return the control to the minimum (counterclockwise) position. A stored waveform of moderate brightness should remain.

6. Press the upper ERASE button and release it. Note that only the portion of the stored image on the upper storage screen (upper half of the CRT screen) has been erased.

7. Press the upper STORE button and then release it to set the switch to non store. The image on the lower screen will not be affected when the upper screen is switched to non-store mode.

8. Press the lower ERASE button and release it. The remainder of the stored display is now erased.

9. Set the lower STORE switch to non store.

10. Increase the intensity to produce a normal display, vertically position the entire waveform on the upper screen, then rotate the INTENSITY control counterclockwise.

11. Press in only the upper STORE button.

12. Increase the intensity to the normal display level, then return the INTENSITY control to the counterclockwise position. The waveform is now stored on the upper screen only, operating independently.

13. The demonstration may be repeated using only the lower screen in the storage mode. At the end of the demonstration, set the STORE switches to non store.

**Single-Sweep Storage.** This method is used for single-sweep events that produce adequate stored displays.

1. Set up a normal-intensity non-store calibrator display as in "First Time Operation."

2. Set the time-base Normal-Single Sweep switch to Single Sweep.

3. Press in both STORE buttons.

4. Apply a single sweep of the trace by pressing the Normal-Single Sweep switch down to the Reset position and releasing it. A stored display of the calibrator waveform should remain on the storage screen. If not, repeat the demonstration with the display intensity increased slightly.

5. Simultaneously press both ERASE buttons to clear the storage screens, then continue with the Trace Location demonstration.

**Trace Location.** The LOCATE button permits the trace or display to be located vertically while the sweep is held off, so that it can be positioned to a new level before storing. The intensity of the trace or display during locate is independent of the intensity control.

1. Continuing from the preceding demonstration, press the LOCATE pushbutton and hold it in. Note that two dots

of normal intensity appear at the left edge of the stored waveform.

2. With the LOCATE button still held in, position the two dots to the upper screen with the amplifier Position control.

3. Release the LOCATE button and press the Normal-Single Sweep switch down to the reset position, writing a display on the upper storage screen.

4. Press the LOCATE button and position the two dots to the lower screen (see Fig. 2-3).

5. Release the LOCATE button and press the Normal-Single Sweep switch down to the reset position, writing a display on the lower storage screen. Both screens should now have stored calibrator waveforms.

6. At the end of the demonstration, set both STORE switches to non store.

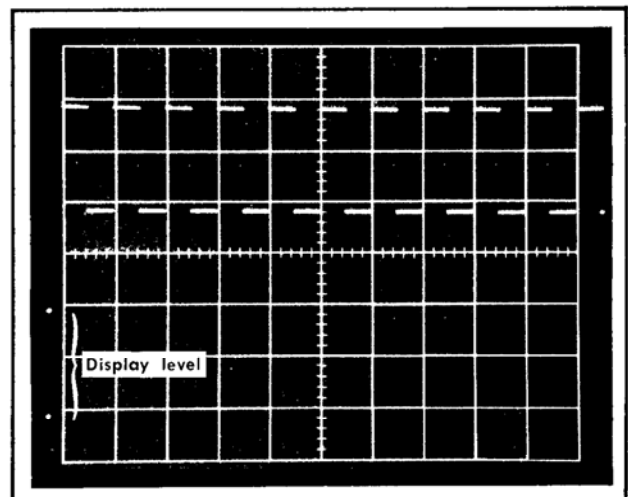

Fig. 2-3. Use of the LOCATE button for positioning the display level while the sweep is held off.

### NOTE

Be sure the waveform is positioned so the sweep starts at the left edge of the graticule for proper operation of the Locate feature. The LOCATE button can be used with sweep magnifier on, but horizontal repositioning is likely to be required.

**Integrated Fast-Rise Waveforms.** The INTEGRATE button, when used in conjunction with the INTENSITY control as described in this demonstration, permits the storage of relatively fast-rising and fast-falling portions of a waveform. This method may also be used for producing a high resolution display of a low-jitter repetitive waveform.

1. Connect a 25-kHz square-wave signal ( $T_r \approx 20$  ns) to the amplifier unit input.

2. Set the controls as given in "First Time Operation," except for the following:

Volts/Div	5
Time/Div	20 $\mu$ s

3. Adjust the INTENSITY control for normal brightness of the free-running trace.
4. Adjust the amplifier Volts/Div switch and the square-wave amplitude to produce about 3 major divisions of vertical deflection on the CRT screen.
5. Trigger the square-wave display and adjust the focus.
6. Press in both STORE buttons and attempt to store the waveform by the previous methods. Note that even though the vertical portions of the waveform are visible when the writing beam is displayed, they cannot be stored well with the methods described previously.
7. Turn the INTENSITY control fully counterclockwise.
8. Simultaneously press both ERASE buttons to clear the CRT screen.
9. Press the INTEGRATE button and hold it in.
10. Advance the INTENSITY control until the vertical positions of the trace are just barely visible.
11. Hold the INTEGRATE button for a few seconds, then turn the INTENSITY control to minimum while the INTEGRATE button is still pressed.
12. Release the INTEGRATE button. Both the horizontal and vertical segments of the display should now be stored (see Fig. 2-4).

13. Repeat this demonstration several times using slightly different intensity levels and integrating for different lengths of time. Best resolution is generally produced by using very low intensity and integrating for a long period (many seconds). However, using this method, only the portions of the trace that can be seen (at least dimly) will be stored.

**CAUTION**

Do not attempt to store extremely fast-rising or fast-falling portions of waveforms viewed at relatively slow sweep rates. The high trace intensity required (due to the intensity difference between the horizontal and the vertical segments) would cause storage target damage.

14. At the end of the demonstration, turn the INTENSITY control fully counterclockwise and set the STORE switches to non store.

**Fast Single-Sweep Enhancement**

The Enhance mode provides a method of storing single-sweep displays that exceed the normal writing speed of the instrument. This mode is not normally used for repetitive sweeps.

1. Apply a 25-kHz square-wave signal ( $T_r \approx 20$  ns) to the amplifier unit input.
2. Set the controls as given in "First Time Operation," except for the following:

Volts/Div	10
Time/Div	10 $\mu$ s

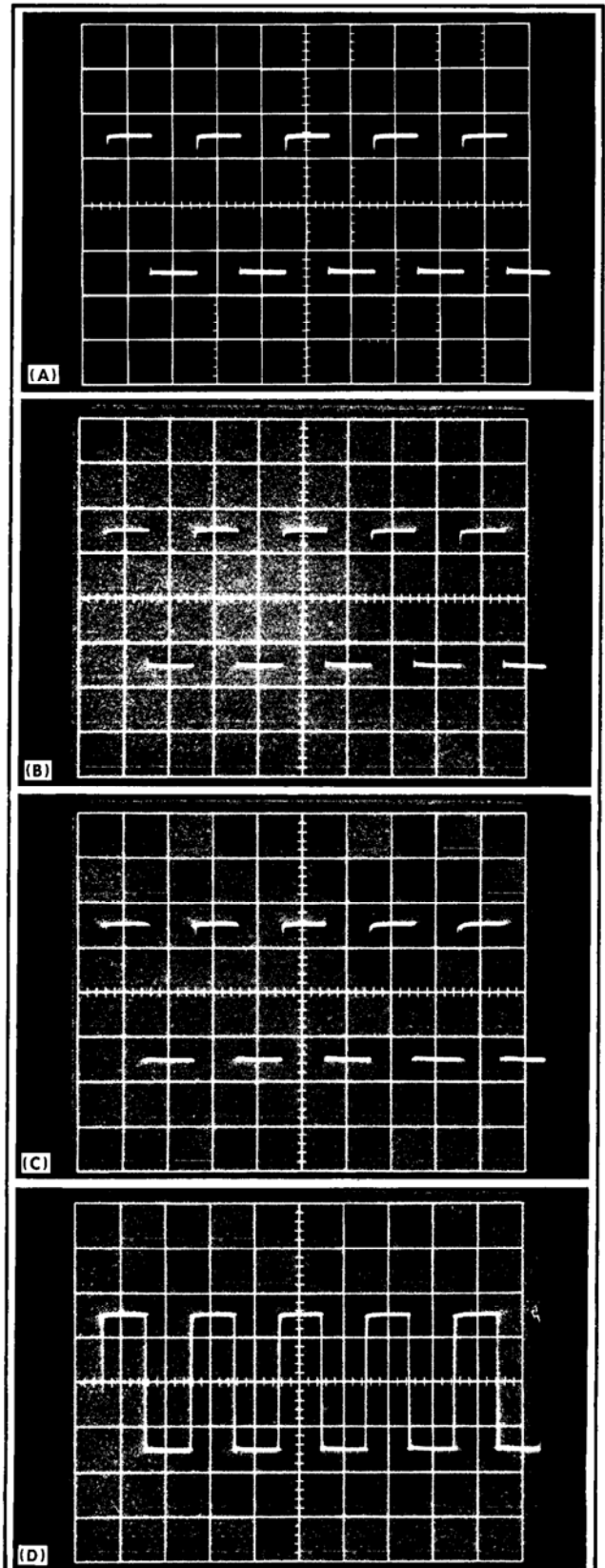

Fig. 2-4. Storage of fast-rise waveform showing difference in storage techniques: (A) non-store display; (B) stored with INTENSITY control alone; (C) stored with INTEGRATE button; (D) stored with INTEGRATE button and INTENSITY control as described in text.

## Operating Instructions—Type R564B

3. Adjust the INTENSITY control to observe the trace.
4. Set the amplifier unit Volts/Div switch and the square-wave amplitude to display about 3 major divisions of deflection.
5. Trigger the display and position it to the upper storage screen.
6. Set the Normal-Single Sweep switch to Single Sweep.
7. Apply several single sweeps of the trace and advance the INTENSITY control to observe the display. Adjust the FOCUS control for a well-defined display.

### CAUTION

Do not allow the time-base Normal-Single Sweep switch to be set to Normal while the intensity is set at a high level.

8. Press in the upper STORE button.
9. Apply a single sweep of the trace. Note that the trace will not store.
10. Push in the upper ENHANCE button.
11. While repeatedly applying single sweeps, adjust the Enhance LEVEL control sufficiently clockwise until the display stores completely.
12. Erase the display and apply a single sweep of the trace. The display should now store.
13. Press the LOCATE button in and position the display to the lower screen.
14. Press in the lower STORE and ENHANCE buttons.
15. Apply a single sweep of the trace. The display should now be stored on both screens.
16. Erase the screens and repeat the demonstration several times using different settings of the LEVEL control.
17. At the end of the demonstration, reset the following controls:

INTENSITY	Counterclockwise
STORE (both)	Off (out)
ENHANCE (both)	Off (out)
Normal-Single Sweep	Normal

## GENERAL OPERATING INFORMATION

### Scale Illumination

The CRT is edge-lighted by three small lamps at the bottom. The lighting can be adjusted to suit the ambient light conditions by means of the SCALE ILLUM control. Rotating the control clockwise increases the brightness of the graticule scale markings.

### Intensity Control

The setting of the INTENSITY control may affect the correct focus of the display. Slight adjustment of the FOCUS control may be necessary when the intensity level is changed.

Do not leave a bright, sharply focused spot on the CRT screen for a prolonged period. An excessively bright stationary spot may damage the CRT phosphor.

### Astigmatism Adjustment

For most displays, the trace can be adequately focused using only the front-panel FOCUS control. However, whenever a large change is made in the beam intensity (to offset large changes in sweep rates or triggering repetition rates), or when plug-in units are changed, adjustment of the ASTIGMATISM control may also be required for a sharp display.

To check for proper setting of the ASTIGMATISM adjustment, slowly turn the FOCUS control through the optimum setting with a signal displayed on the CRT screen. If the ASTIGMATISM adjustment is correctly set, the vertical and horizontal portions of the trace will come into sharpest focus at the same position of the FOCUS control.

To set the ASTIGMATISM adjustment, use the following procedure:

1. Connect a 4 V Calibrator signal to the vertical input and set the corresponding Volts/Div switch to present 2.5 divisions of vertical deflection.
2. Set the Time/Div switch .2 ms.
3. Adjust the INTENSITY control so that the rising portion of the display can be seen.
4. Alternately adjust the FOCUS and ASTIGMATISM controls so that the horizontal and vertical portions of the display are equally focused.

### Graticule

The graticule of the Type R564B is marked with eight vertical and 10 horizontal divisions. Each division is one centimeter square. In addition, each major division is divided into five minor divisions on the center vertical and horizontal lines. With the vertical gain and horizontal timing calibrated to the graticule, accurate measurements can be made from the CRT. The illumination of the graticule lines can be varied with the SCALE ILLUM control.

### Trace Alignment Adjustment

If a free-running trace is not parallel to the horizontal graticule lines, set the TRACE ALIGNMENT adjustment as follows. Position the trace to the center horizontal line. Adjust the TRACE ALIGNMENT adjustment so the trace is parallel with the horizontal graticule lines.

### 1 kHz Calibrator

The 1 kHz Calibrator provides a convenient source of square waves of known amplitude at an accurate frequency of one kilohertz. The output square-wave voltages available at the CAL OUT connector are 4 mV, 40 mV, 0.4 V, 4 V and 40 V. The loading of a terminated 50  $\Omega$  system at the CAL OUT connector will provide output square-wave voltages of 2 mV, 20 mV and 0.2 V. A constant 40-volt DC level is also provided.

The current link provides 10 milliamperes, available as either DC or a square-wave current signal, which can be used to check and calibrate current probe systems. This current signal is obtained by clipping the probe around the current loop. The arrow indicates conventional current (i.e., positive to negative).

### Intensity (Z-Axis) Modulation

Intensity modulation can be used to relate other voltage information to the displayed signal without changing the shape of the waveform. The modulating signal is AC-coupled to the CRT cathode through the rear-panel EXT INPUT connector and the CRT CATHODE SELECTOR switch. With the INTENSITY control set correctly, a positive excursion will dim or blank the CRT beam, and a negative excursion will brighten the beam (see Section 1 for amplitudes).

Time markers may be applied for direct time reference of the display or for establishing the sweep rate when uncalibrated deflection is used. Fast-rise pulses of short duration provide best resolution with respect to time. If the markers are not time-related to the displayed waveform, a single sweep display is required. If sine waves are used for Z-axis modulation, the minimum usable frequency is about 250 hertz, due to AC coupling at the input. Be sure the CRT CATHODE SELECTOR is in the NORMAL position when the EXT INPUT connector is not used, to avoid random intensity modulation from stray signals.

Since there is only one intensity level in a stored display, Z-axis information can be stored only by modifying the display in some manner. The stored waveform may be modified by either dimming portions of the waveform so they do not store, or brightening portions from a dim background so only the brightened portions store. The following demonstrations illustrate these methods of intensity modulation.

**Modulation by Positive Blanking** (For Stored Displays). The best intensity-modulated stored displays are usually produced by applying positive modulation pulses that lower the intensity of the modulated portions below the storage threshold.

1. Apply an approximate 30-volt, one-microsecond positive-going time-mark signal to the CRT cathode EXT INPUT and to the time-base Ext Trig input.

2. Set the controls as in "First Time Operation," except for the following:

Time/Div	2 $\mu$ s
Triggering Source	Ext

3. Adjust the INTENSITY, FOCUS and ASTIGMATISM controls for a well-defined trace.

4. Set the CRT CATHODE SELECTOR to EXT INPUT and adjust the Triggering Level control for a stable display.

5. The display should consist of a horizontal trace with blanked portions occurring every one microsecond.

6. Press in both STORE buttons, then rotate the INTENSITY control clockwise. When the operation is performed correctly, only the unmodulated portions of the display should be stored (see Fig. 2-5A).

7. At the end of the demonstration, set the STORE switches to non store and the CRT CATHODE SELECTOR to NORM.

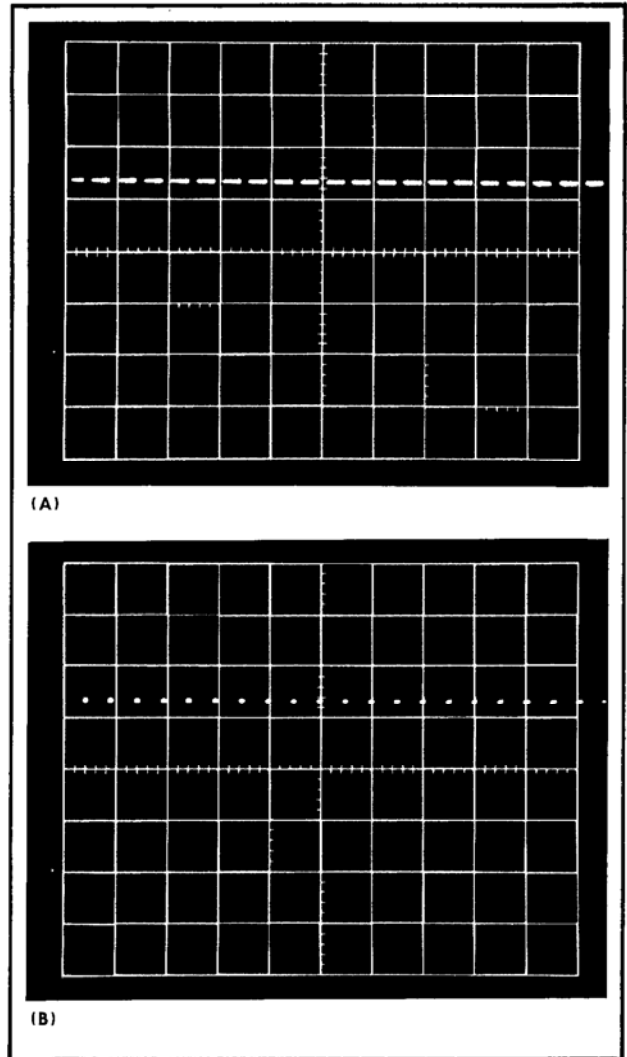

Fig. 2-5. Typical CRT displays showing intensity modulation for stored displays; (A) positive-pulse blanking, and (B) negative-pulse intensification.

**Modulation by Negative Intensification.** The procedure is as follows:

1. Apply an approximate 10-volt, one-microsecond negative-going time-mark signal from the marker amplifier output of the time-mark generator to the CRT cathode EXT INPUT and to the time-base Ext Trig input.

2. Set the controls as in "First Time Operation," except as follows:

Time/Div	2 $\mu$ s
Triggering Slope	—
Triggering Source	Ext

3. Adjust the INTENSITY, FOCUS and ASTIGMATISM controls for a well-defined trace.

4. Set the CRT CATHODE SELECTOR to EXT INPUT and adjust the Triggering Level control for a stable display.

5. The display should consist of a string of dots, spaced one microsecond apart.

## Operating Instructions—Type R564B

6. Press in both STORE buttons, then rotate the INTENSITY control clockwise. When the operation is performed correctly, only the dots should be stored (see Fig. 2-5B).

7. At the end of the demonstration, remove the time-mark signal and set the STORE switches to non store.

### Care of Storage Screens

To prolong the useful life of the storage screens, the following precautions should be observed when operating the Type R564B:

1. Use minimum beam intensity required to produce a clear, well-defined display. Care must be observed in the degree of writing-beam intensity that is used, particularly when using slow sweep rates and sampling displays.

2. Turn the INTENSITY control to minimum when changing plug-in units. An undeflected spot on the CRT screen can burn the storage target, even at normal intensity.

3. Do not increase beam intensity to store fast-changing portions of a waveform. See instructions given earlier in this section for storing fast-rise waveforms.

4. Avoid repeated use of the same area of the screen.

5. Do not leave display on CRT screen (either writing or stored) when the display is not needed.

6. Do not leave STORE switches pushed in when the storage mode is not needed.

### Non-Store Operation

Operation of the Type R564B in the non-store mode is essentially the same as that of a conventional general-purpose oscilloscope; however, a difference in display brightness will be observed (because of the differences in CRT construction, aluminizing, phosphors, etc.) between the CRT's of the Type R564B and a conventional oscilloscope. The

various display modes that are possible with a particular pair of plug-in units are described in the instruction manuals for those units. Refer to the amplifier unit manual for the following: Compensation of probes; selection and use of input cables, coupling and attenuation; measurement of input signal voltage and phase (X-Y). Refer to the time-base unit manual for selection of triggering sources and coupling and for measurements of time intervals, frequency and phase (linear measurement).

### Display Photography

A permanent record of the CRT display may be obtained through the use of a trace-recording camera. When the Type R564B Oscilloscope is operated in non-store mode, trace photography is accomplished in essentially the same manner as with a conventional oscilloscope. Use a normal trace intensity and set the graticule illumination so that it is approximately two-thirds as bright as the trace. See the instructions accompanying the camera for specific techniques.

When the oscilloscope is operated in storage mode, the display may be stored and erased as many times as is necessary to obtain the desired display characteristics before a picture is taken. For non-repetitive waveforms and certain other applications, the ability to compose the display in advance permits the saving of a considerable quantity of film.

Due to the presence of a background glow on the storage screens, special care must be taken in the exposure times and f-stop settings that are used. Of course, these will depend on the type of film used. The graticule illumination should be set to a level slightly less bright than the stored waveform. The trace-to-background contrast in the developed picture is generally improved by allowing the film to overdevelop slightly.

Most of the pictures of storage-mode displays shown in this manual were taken on ASA3000 medium-contrast film at about 1/10th second and f5.6. Greater contrast can be obtained with a high-contrast type of film.



## SECTION 3

# CIRCUIT DESCRIPTION

Change information, if any, affecting this section will be found at the rear of the manual.

### Introduction

This section of the manual contains a description of the circuitry used in the Type R564B Storage Oscilloscope. Each circuit is described in detail, using a detailed block diagram to show the interconnections between the stages in each major circuit and the relationship of the front-panel controls to the individual stages. Complete schematic diagrams are located at the back of this manual.

## LOW-VOLTAGE POWER SUPPLY

### General

The Low-Voltage Power Supply circuit provides the operating power for this instrument from four regulated supplies. Electronic regulation is used to provide stable, low-ripple output voltages. Each regulated supply contains a short-protection circuit to prevent instrument damage if a supply is inadvertently shorted to ground or to another supply. The voltage input stage includes the Voltage Selector Assembly which allows selection of the nominal operating voltage and regulating range for the instrument. Fig. 3-1 shows a detailed block diagram of the Low-Voltage Power Supply.

### Power Input

Power is applied to the primary of transformer T1 through fuse F1, POWER switch SW1, thermal cutout TK1, Voltage Selector switch SW2 and Range Selector switch SW3. SW2 connects the split primaries of T1 in parallel for 115-volt nominal operation, or in series for 230-volt nominal operation. SW3 allows three ranges of regulation by changing the taps on the primary windings to fit different line requirements. A second fuse, F2, is connected into the circuit when SW2 is set to the 230 V position to provide the correct protection for 230-volt operation.

Thermal cutout TK1 provides thermal protection by interrupting the power if the instrument overheats. When the temperature returns to a safe level, TK1 automatically closes to re-apply the power.

### —100-Volt Supply

The —100-Volt Supply provides the reference voltage for the remaining supplies. The output from the secondary of T1 is rectified by bridge rectifier D8A-D. This voltage is filtered by C9, then applied to the —100-Volt Series Regulator stage to provide a stable output voltage. The Series Regulator can be compared to a variable resistance which

is changed to stabilize the output voltage. The conductance of the Series Regulator stage is controlled by the Error Amplifier to provide the correct regulated output voltage.

The Error Amplifier consists of Q12 and Q14, which are connected as a comparator. The output at the collector of Q14 indicates that voltage variations occurred at the base of Q14 relative to the fixed voltage at the base of Q12. Zener diode D10 maintains a fixed 9-volt drop, setting the base of Q12 at about —9 volts. The base level of Q14 is determined by the voltage divider network R18-R19-R20-R21-R23. R23, the —100 Volts adjustment, allows the operating point of the Error Amplifier to be adjusted to set the output voltage of the supply at —100 volts. R13 is the emitter resistor for both comparator transistors and the current through it divides between Q12 and Q14. The output current of the Error Amplifier stage controls the conduction of the Series Regulator stage. This is accomplished as follows: Assume that the output voltage increases (becomes more negative) because of a change in load or an increase in line voltage. This negative-going voltage change at the output is applied to the base of Q14, reducing the conduction of Q14. As current through Q14 is reduced, Q24 base current increases. This results in increased Q24 collector current, increasing the voltage drop across R25 and R26 and pulling the base of Q28 negative. The emitter of Q28 follows the base, hence, the base of Q32 is also pulled negative. Reduced current through the Series Regulator Q32 decreases current through the load, causing the output voltage to decrease (become less negative) to its correct level. These changes occur rapidly, and the effect is to maintain unchanged output voltage. In a similar manner, the Series Regulator and Error Amplifier stages compensate for output changes due to ripple. As will be seen in subsequent paragraphs, R33 determines the limit current for the Series Regulator stage, and thus for the load. Transients beyond the frequency range of the regulator are filtered by C31 to prevent their appearance on the output voltage.

When the power switch is activated, diode D25 provides a base current path for Q28, allowing the —100-Volt Supply to turn on first, since all the other supplies are dependent upon its output. As the —100-Volt Supply output builds up to its correct level, D25 is reverse biased and remains off during normal operation of the instrument.

The Short-Protection Amplifier stage, Q30, protects the —100-Volt Supply if the output is shorted, and also serves to limit the current demanded from the Series Regulator under excessive load. During normal operation, divider R30-R31 sets the base of Q30 to a point below the turn-on level of the transistor. When excess current is demanded from Series Regulator Q32 due to an overload or short circuit, the additional current through R33 raises the emitter of Q32 more positive. This produces a corresponding change at

Circuit Description—Type R564B

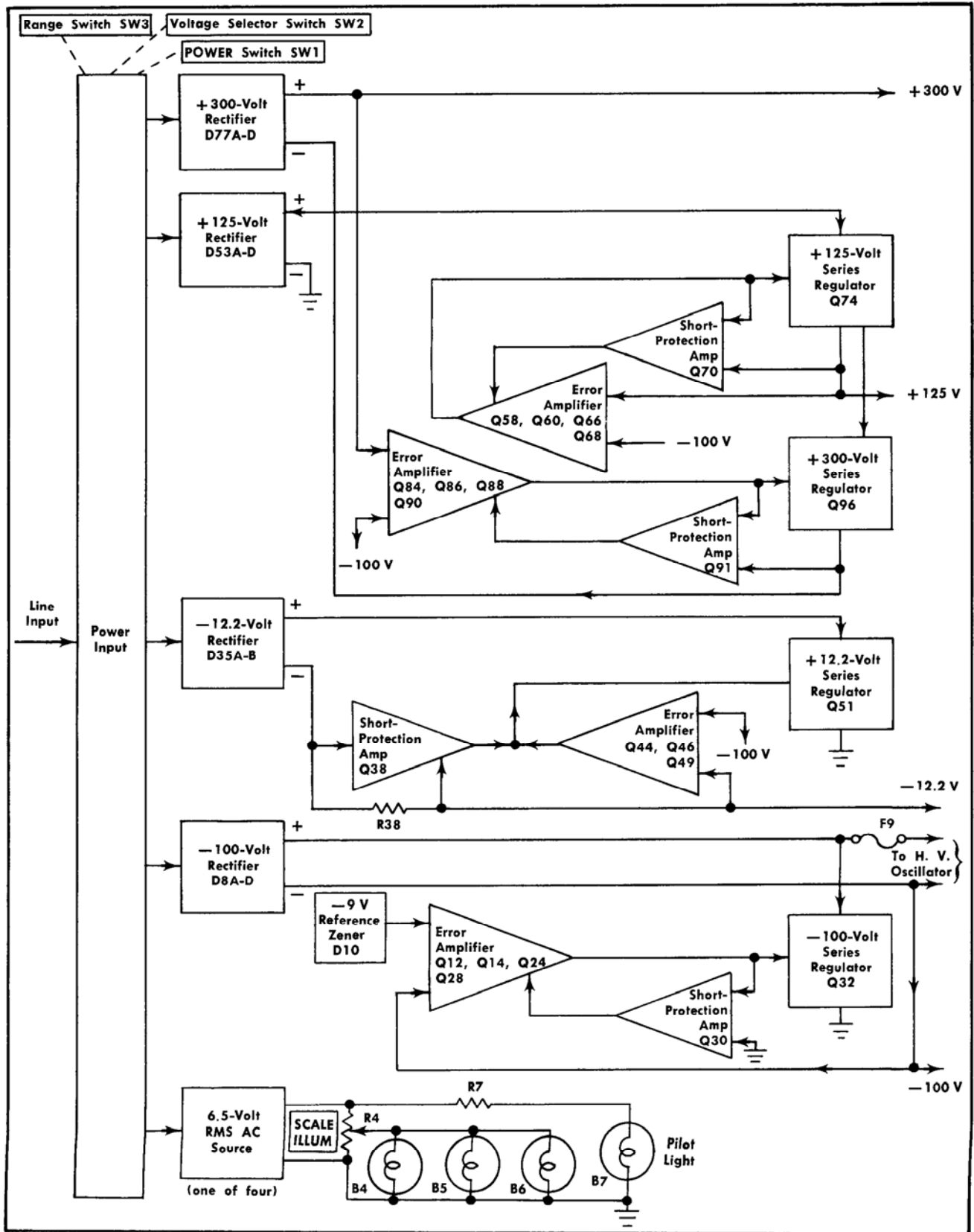

Fig. 3-1. Power Supply detailed block diagram.

the base of Q32, which is connected through R30 to the base of Q30. This positive-going change biases Q30 into conduction. As a result, less current is available to Q28, to Q32 and to the load, thus causing the supply to lose regulation. R31 senses the decrease in load voltage and adds to increasing base current of Q30. As the collector of Q30 goes negative, conduction of Q28 and Q32 is further decreased. Thus the output current is decreased and remains low until the excessive load is removed. D19, together with divider R18-R19-R20, provides protection to the -12.2-Volt Supply in the event the -100-Volt Supply is shorted to the -12.2-Volt Supply. In the event of a short, the -100-Volt supply is caused to lose regulation and therefore lose reference voltage for the -12.2-Volt Supply. D31 protects the -100-Volt Supply from damaging polarity reversal if it is shorted to either the +125-Volt Supply or the +300-Volt Supply.

### -12.2-Volt Supply

Rectified voltage for operation of -12.2-Volt Supply is provided by D35A-B, filtered by C36 and applied to the -12.2-Volt Supply Series Regulator stage. Reference voltage for this supply is provided by voltage divider R42-R43 between the regulated -100-Volt Supply and ground. If the -12.2-volt output changes, a sample of the change appears at the base of Q46 as an error signal. Regulation of the output voltage is controlled by Error Amplifier Q44-Q46-Q49 and Series Regulator Q51 in a manner similar to that described for the -100-Volt Supply. Transients beyond the frequency range of the regulator are filtered by C47.

Short protection is provided by Q38 and R38. For normal operation, the emitter-base voltage of Q38 is not enough to bias it into conduction. However, when the output is shorted, the high current demanded from the -12.2-Volt Supply is drawn through R38, producing a voltage drop sufficient to forward bias Q38. Q38 collector current then produces an increased voltage drop across R40, reducing the conduction of both Q49 and Q51 to limit the output current. R39 protects Q38 from sudden current surges by limiting the base current. D47 protects the -12.2-Volt Supply from damage if it is shorted to either the +125-Volt Supply or the +300-Volt Supply.

### +125-Volt Supply

Rectified voltage for operation of the +125-Volt Supply is provided by D53A-D, filtered by C54 and applied to the +125-Volt Supply Series Regulator stage. The +125-Volt output is summed with the -100-volt reference through divider R62-R63, and the summation is applied through R61 to the base of Q60 and compared to the grounded base of Q58. If the +125-volt output changes, a sample of the change appears at the base of Q60 as an error signal. Regulation of the output voltage is controlled by Error Amplifier Q58-Q60-Q66-Q68 and Series Regulator Q74 in a manner similar to that described for the -100-Volt Supply. Transients beyond the frequency range of the regulator are filtered by C97B-C to prevent their appearance on the output voltage.

Short protection for this supply is provided by the Short-Protection amplifier stage, Q70, which functions in a manner similar to that described for Q30 in the -100-Volt Supply. D62 protects the Error Amplifier from damage if the output

of the +125-Volt Supply collapses or goes negative, causing C62 to rapidly discharge and reverse bias Q60. Diode D75 protects electrolytic capacitor C97B-C and the transistors in the circuit from damaging polarity reversals in the event the +300-volt output is shorted to ground or to one of the negative supplies. D76 causes the +125-Volt Supply to go into current limiting when the +300-Volt Supply is shorted to ground or to one of the negative supplies.

### +300-Volt Supply

Rectified voltage for operation of the +300-Volt Supply is provided by D77A-D, filtered by C78 and applied from the negative side of the rectifier to the +300-Volt Supply Series Regulator stage. The +300-volt output is summed with the -100-volt reference through divider R80-R81, and the summation is applied through R83 to base of Q84 and compared to grounded base of Q86. If the +300-volt output changes, a sample of the change appears at the base of Q84 as an error signal. Regulation of the output voltage is controlled by Error Amplifier Q84-Q86-Q88-Q90 and Series Regulator Q96 in a manner similar to that described for the -100-Volt Supply. Transients beyond the frequency range of the regulator are filtered by C97A. The load current through Series Regulator Q96 also passes through the +125-Volt Supply Series Regulator, Q74. However, this does not affect the limit current of the +125-Volt Supply.

Shorting protection for this supply is provided by the Short-Protection Amplifier stage, Q91, which functions in a manner similar to that described for Q30 in the -100-Volt Supply. D80 protects the Error Amplifier from damage if the output of the +300-Volt Supply collapses or goes negative, and D95 protects the transistors in the circuit from damaging polarity reversals in the event the +125-Volt Supply is shorted to ground or to one of the negative supplies.

### 6.5-Volt RMS AC Source

The four 6.5-volt RMS secondary windings of T1 provide power for the CRT heater, the plug-in heaters via J11 and J21, the pilot light, B7, and the scale illumination lights, B4, B5, and B6. Current through the scale illumination lights is controlled by the SCALE ILLUM control, R4, to change the brightness of the graticule lines.

### DEFLECTION CIRCUITS

Push-pull horizontal and vertical signals for deflecting the writing-gun beam are received through pins 17 and 21 of each plug-in connector (J11 and J21) and applied to the respective deflection plates of the CRT. The effective deflection circuit capacitance encountered by each of these signals at the plug-in connector affects the bandwidth and phase shift of the plug-in unit. Compensating capacitors C102 and C109 (shown on the Plug-In Connectors diagram) are factory adjusted to set the effective capacitance at a standard value of 14.3 picofarads to ensure plug-in compatibility.

When the sweep start is positioned to the left edge of the graticule and the LOCATE button is pushed (see CRT

**Circuit Description—Type R564B**

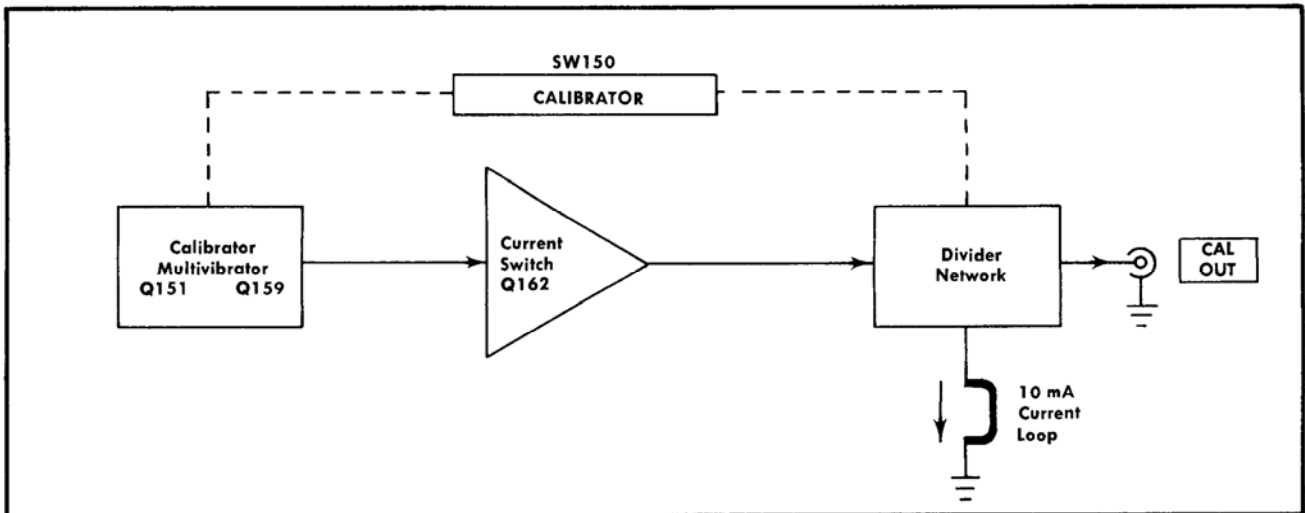

Fig. 3-2. 1 kHz Calibrator detailed block diagram.

Circuit), the writing-gun beam is deflected to the preview area at the left side of the CRT screen, permitting the beam to be located without altering a stored display. This is accomplished by applying a positive voltage via R105 and D105 to the left-hand horizontal deflection plate.

**1 kHz CALIBRATOR**

**General**

The 1 kHz Calibrator circuit produces a square-wave output with accurate amplitude and frequency. This output is available as a square-wave voltage at the CAL OUT connector or as a square-wave current through the 10 mA probe current loop. An accurate +40 volts DC level is also available. The CALIBRATOR switch selects the attenuation of the output signal to provide square-wave voltage outputs between 40 volts and 4 millivolts (between 0.2 volts and 2 millivolts into 50 ohms) peak to peak. Fig. 3-2 shows a detailed block diagram of the 1 kHz Calibrator circuit.

**Calibrator Multivibrator**

The Calibrator Multivibrator is comprised of Q151 and Q159, and is a free-running emitter-coupled multivibrator<sup>1</sup>. The circuit operates in a symmetrical manner and the output is an accurate one-kilohertz square wave. Only an approximate 9-volt change is exhibited at the emitters of Q151 and Q159, so that an essentially constant current of about 0.8 mA is maintained through resistors R150 and R158.

Refer to the waveforms shown in Fig. 3-3 for this discussion. With the CALIBRATOR switch, SW150, in all positions except 10 mA DC and OFF, the emitters of Q151 and Q159 are returned to the +125-Volt Supply through D151-R150 and D159-R158. Assume that the multivibrator has just switched states; Q151 is off and Q159 is on. This is T<sub>0</sub> in Fig. 3-3 the base potential of Q159 is set to about -11.0 volts by voltage divider R153-R154-R156 to ensure that Q159 will not saturate. The voltage at the anode

<sup>1</sup>Jacob Millman and Herbert Taub, "Pulse, Digital, and Switching Waveforms," McGraw-Hill, New York, 1965, pp. 445-451.

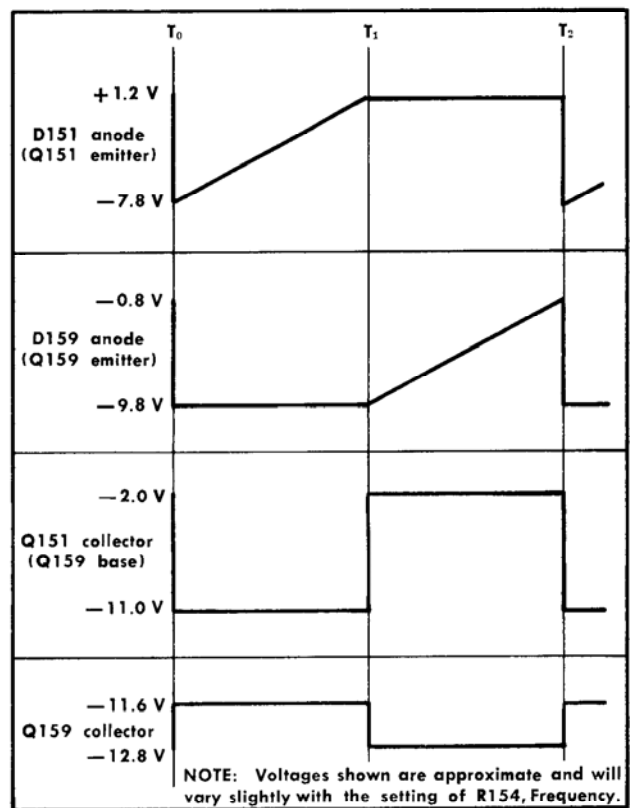

Fig. 3-3. Calibrator Multivibrator waveforms.

of D159 is about -9.8 volts because of the voltage drop across two forward biased junctions. Capacitor C157 has about a 2-volt charge as switching occurs; thus, the voltage at the anode of D151 is about -7.8 volts, cutting off Q151. C157 begins to charge toward the +125-Volt Supply via R150. Total current through Q159 is about 1.6 mA; 0.8 mA through R158 and 0.8 mA through C157 and R150.

After about 0.5 milliseconds (corresponding with  $T_1$  in Fig. 3-3, C157 has charged to the turn-on level of Q151 and D151. At this point, the capacitor has a charge of about 11 volts and the potential at the anode of D151 is about +1.2 volts. The capacitor charging current through Q159 ceases as Q151 and D151 begin to conduct. As the collector of Q151 (hence the base of Q159) rises, Q159 and D159 are switched off and C157 begins to discharge through R158. The C157-R158 current sums with the R150 current through Q151, producing an approximate 9-volt positive-going step at the base of Q159.

C157 continues to discharge, and after 0.5 milliseconds ( $T_2$  in Fig. 3-3), the voltage at the anode of D159 has risen to forward bias Q159 and D159. As Q159 begins to conduct, the anode of D159 is clamped at about -0.8 volts and discharge action of C157 is halted. The current through Q151 decreases, causing its collector to introduce a negative-going step, which is connected through the Q159 base-emitter junction and D159 to C157. Because C157 cannot obtain an instantaneous charge, the anode of D151 is pulled negative to reverse bias D151 and Q151. Q151 turns off, and its collector falls rapidly to about -11.0 volts, resulting in an approximate 9-volt negative-going step applied through Q159 and D159 to C157. The anode of D151 is pulled down to about -7.8 volts, completing the cycle.

The Calibrator Multivibrator circuit has been designed to repeat the preceding sequence at an accurate one-kilohertz frequency. However, since a tolerance range of the passive components does exist, the frequency can be adjusted by varying the amplitude slightly across C157 during the charge-discharge cycle. This is accomplished by adjustment of R154, Frequency, which determines the potential on D159 anode at the instant the diode turns on. For example, with greater amplitude, longer charge and discharge times are required, thus lowering the frequency.

## Output Stage

The output stage consists of the Current Switch, Q162, and the Divider Network. During the half cycle that Q159 is conducting, current is injected into the base of Q162. Q162 saturates and its collector drops to about -12 volts, reverse biasing D168. With D168 off, there is no current through R170 and R171, and the output level at the cathode of D168 drops to zero volts.

When Q159 turns off, Q162 turns off and D161 turns on to protect the Q162 base-emitter junction from reverse-bias breakdown. D164 and D168 turn on, and the output of the circuit (at D168 cathode), is dependent upon voltage divider R166-R167-R170-R171 between +125 volts and ground. This output level is set to exactly +40 volts by adjustment of R166, Amplitude. When this adjustment is made, the current through the divider is an accurate 10 mA which is available at the current probe loop in the 10 mA positions of the CALIBRATOR switch.

The signal voltage available at the CAL OUT connector is determined by the divider network (made up of precision resistors) and the setting of the CALIBRATOR switch. In the 10 mA DC (40 VDC) position, the Calibrator Multivibrator is inoperative so that a +40-volt DC output level is produced. R173 is placed in series with the R166-R167-R170-R171 resistance to obtain an effective resistance of 450 ohms with

4 volts applied, as seen by the CAL OUT connector in the 4 V position of the switch. This effective resistance becomes part of the output voltage divider in the positions of 0.4 V and below (these positions have an accurate 50-ohm output resistance, which when terminated by 50 ohms can further divide the outputs by two, providing outputs of 0.2 V, 20 mV and 2 mV). In the 10 mA position, the CAL OUT connector is grounded.

R183, which is about ten times the resistance of the braid of a 42-inch coaxial cable, cancels any ground loop current that may exist between the CAL OUT connector and some other instrument chassis.

## CRT CIRCUIT

### General

The CRT Circuit provides the high voltage and control circuits necessary for operation of the cathode-ray tube (CRT). Fig. 3-4 shows a detailed block diagram of the CRT Circuit.

### High Voltage Oscillator

Q219 and its associated circuitry comprise a class C oscillator<sup>2</sup> to provide the drive for the high-voltage transformer, T220. When the instrument is turned on, conduction of Q214 provides a base current path for Q219. The collector current of Q219 increases and a voltage is developed across the collector winding of T220. This produces a corresponding voltage increase in the feedback winding of T220 which is connected to the base of Q219, causing it to conduct harder. While Q219 is conducting, C217 charges negatively to the peak to peak voltage of the feedback winding. Eventually the rate of collector current increase in Q219 becomes less than that required to maintain the voltage across the collector winding, and the voltage drops. This turns off Q219 by way of feedback voltage to the base. During the interval that Q219 is not conducting, the negative charge on C217 is partially removed through Q214. Q219 remains off until the feedback voltage on the base is near the peak positive value again. The cycle repeats at a frequency of 40 to 50 kilohertz. The amplitude of sustained oscillation depends upon the average current delivered to the base of Q219, and finally, the average Q219 collector current.

### High Voltage Regulator

Feedback from the secondary of T220 and +125 volts are summed through the voltage divider network consisting of R200, R201, R206, R208 and R233 through R238, and the difference is applied to the gate of Field-Effect Transistor Q211. This sample of the output voltage is compared to the regulated -12.2-volt level at the source of Q211. It is then inverted and amplified by Q211 and applied to the base of Q214. Amplitude of the oscillations at the collector of Q219 is determined by the average collector current of Q214.

Regulation is accomplished as follows: If the output voltage at the -3300 V test point starts to go positive (become

<sup>2</sup>Lloyd P. Hunter (ed.), "Handbook of Semiconductor Electronics," second edition, McGraw-Hill, New York, 1962, pp. 14-19—14-21.

Circuit Description—Type R564B

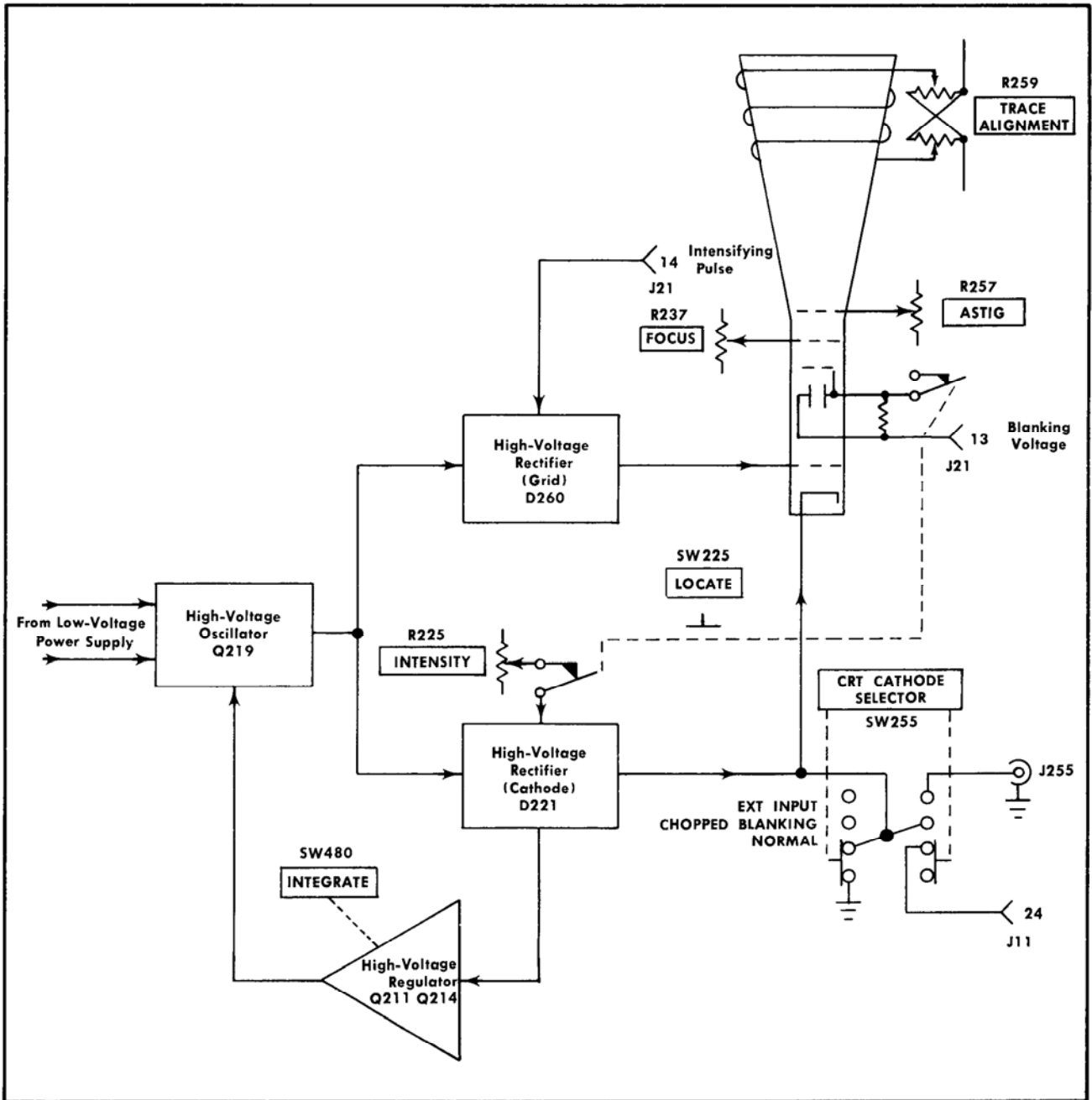

Fig. 3-4. CRT Circuit detailed block diagram.

less negative), a sample of this positive-going voltage is applied to the gate of Q211. Conduction of Q211 is increased, and as its drain goes negative because of the voltage dropped across R211, the base current of Q214 is increased. An increase in conduction of Q214 increases the average collector current, which is applied through the feedback winding of T220 to the base of Q219. Q219 conducts harder, increasing the collector current to produce a larger induced voltage in the secondary of T220. This increased voltage appears as more negative voltage at the -3300 V test point to correct the original positive-going change. By

sampling the output from the cathode supply in this manner, the total output of the high-voltage supply is held constant.

Output voltage level of the high-voltage supply is controlled by the High Voltage adjustment, R206, in the gate circuit of Q211. This adjustment sets the effective divider ratio, which in turn determines the voltage necessary to satisfy the quiescent condition of Q214 and Q219 in the manner described for a change in output voltage. Neon bulb B209 and diode D212 protect the FET, Q211, from damage due to excessive voltage.

The INTEGRATE switch, SW480, grounds R203 in the gate circuit of Q211, which causes a slight shift in the high voltage to correct for the deflection sensitivity changes that occur when the flood gun cathodes are turned off.

### High Voltage Rectifiers and Output

The high-voltage transformer, T220, has two output windings. These windings provide the negative CRT cathode potential and the CRT control grid bias.

The accelerating potential for the CRT cathode is supplied by the half-wave rectifier D221 and held constant by the High-Voltage Regulator stage in the primary of T220. The output level is adjustable to about  $-3300$  volts on the cathode by the High Voltage adjustment mentioned previously. (The 6.5-volt writing gun heater is also elevated to the cathode potential through R246.)

Half-wave rectifier D260 provides a negative voltage for the control grid. The voltage applied to the control grid is determined by the setting of the INTENSITY control (to be discussed in the next paragraph), the CRT Grid Bias control (R269) and any intensification signals received from the time-base plug-in unit (delayed sweep and sampling units only). Reference to ground for this supply is set by the conduction of D272.

Beam current is controlled by R225, INTENSITY. As the control is rotated clockwise, the wiper arm moves toward  $-100$  volts. This more negative DC reference voltage is applied to the secondary winding controlling the CRT cathode, reducing the voltage demanded of the winding to maintain  $-3300$  volts at the  $-3300$  V test point. This is accomplished by the regulator circuit. The voltage across the grid winding is also reduced, which results in a more positive voltage applied to the CRT control grid, thus increasing beam current. Beam current is reduced in a like manner by rotating R225 counterclockwise.

Neon bulbs B277, B278 and B279 provide protection to the CRT if the voltage difference between the control grid and the cathode exceeds about 135 volts.

### CRT Control Circuits

In addition to the INTENSITY control discussed previously, the FOCUS and ASTIGMATISM controls have been incorporated for arriving at the optimum CRT display. FOCUS control R237 provides the correct voltage for the second anode in the CRT. Proper voltage for the third anode is obtained by adjusting ASTIGMATISM control R257. In order to obtain optimum spot size and shape, both the FOCUS and ASTIGMATISM controls are adjusted to provide the proper electrostatic lens configuration in the CRT.

The TRACE ALIGNMENT control, R259, permits adjustment of the DC current through beam-rotation coil L259 to align the display with the horizontal graticule lines.

When the LOCATE button, SW225, is pushed, a dot (or line, if varying vertical deflection is present) will appear to the left of the screen at the display level of the trace, provided that the sweep start is at the left edge of the graticule. This is accomplished by applying a positive deflection voltage to the left horizontal deflection plate and unblanking the CRT writing beam. At the same time, the

INTENSITY control is removed from the circuit and the cathode supply is referred to the voltage set by divider R227-R228. Locate intensity is therefore a fixed value, determined by the setting of the CRT Grid Bias control (R269), and is independent of the INTENSITY setting.

### Blanking

The writing-gun beam is blanked by a special set of deflection plates in the CRT. One of the plates (pin 7) is connected directly to the  $+125$ -Volt Supply through R243, SW225 (LOCATE switch) and R242. The second plate (pin 5) is connected through plug-in connector J21 to the horizontal plug-in unit. When there is no sweep, a quiescent voltage is applied from the horizontal unit to create a difference of potential between the two plates. This voltage can be either positive or negative with respect to the  $+125$  volts on the other plate. The potential difference created is sufficient to deflect the writing-gun beam so that it is absorbed in the deflection structure and does not reach the screen.

The writing-gun beam is unblanked whenever the two deflection plate voltages become equal. For example, if a sweep occurs, if the LOCATE button is pressed, or if the horizontal plug-in unit is removed, the voltages are made equal and the beam is allowed to pass through to the CRT screen. Sweep unblanking is produced by either a positive or negative gate pulse (depending on the quiescent level) applied to pin 5, equaling the  $+125$  volts normally present at pin 7. Beam unblanking when the LOCATE button is pressed is accomplished by disconnecting pin 7 from the  $+125$ -Volt Supply, allowing the two plates to become equalized through R244. In a like manner, when the horizontal plug-in unit is removed, the two deflection plates are equalized through R244 at  $+125$  volts.

### Intensity Modulation

The intensity of the writing-beam display may be modulated by applying signals to either the grid or the cathode of the writing gun.

Intensifying signals from a delayed sweep time-base plug-in unit are applied to the grid supply via pin 14 of the horizontal plug-in inter-connecting socket, J21. These signals brighten the delayed-sweep portion of the delaying-sweep display. When the time-base unit is set to Intensified, the writing-gun grid supply is referred to a negative voltage in the intensifying circuit through D275, reducing the overall display intensity. At this time, D272 is reverse biased by the negative voltage at the juncture of the two diodes. Intensification results when the positive-going pulse from the time-base unit reverse biases D275 and the grid supply is referred to ground through D272 (as for normal operation). The positive-going pulse is then coupled through R275 and C275 to the CRT control grid. Thus the brightened portion of the display is the same intensity as a normal display and the background trace is dimmed.

External modulating signals may also be applied to the writing gun by way of the cathode, through the rear-panel EXT INPUT connector, J255, and the CRT CATHODE SELECTOR, SW255. With the INTENSITY control adjusted properly, a positive or negative pulse between 3 and 50 volts in amplitude will produce dimming or intensification of the writing beam.

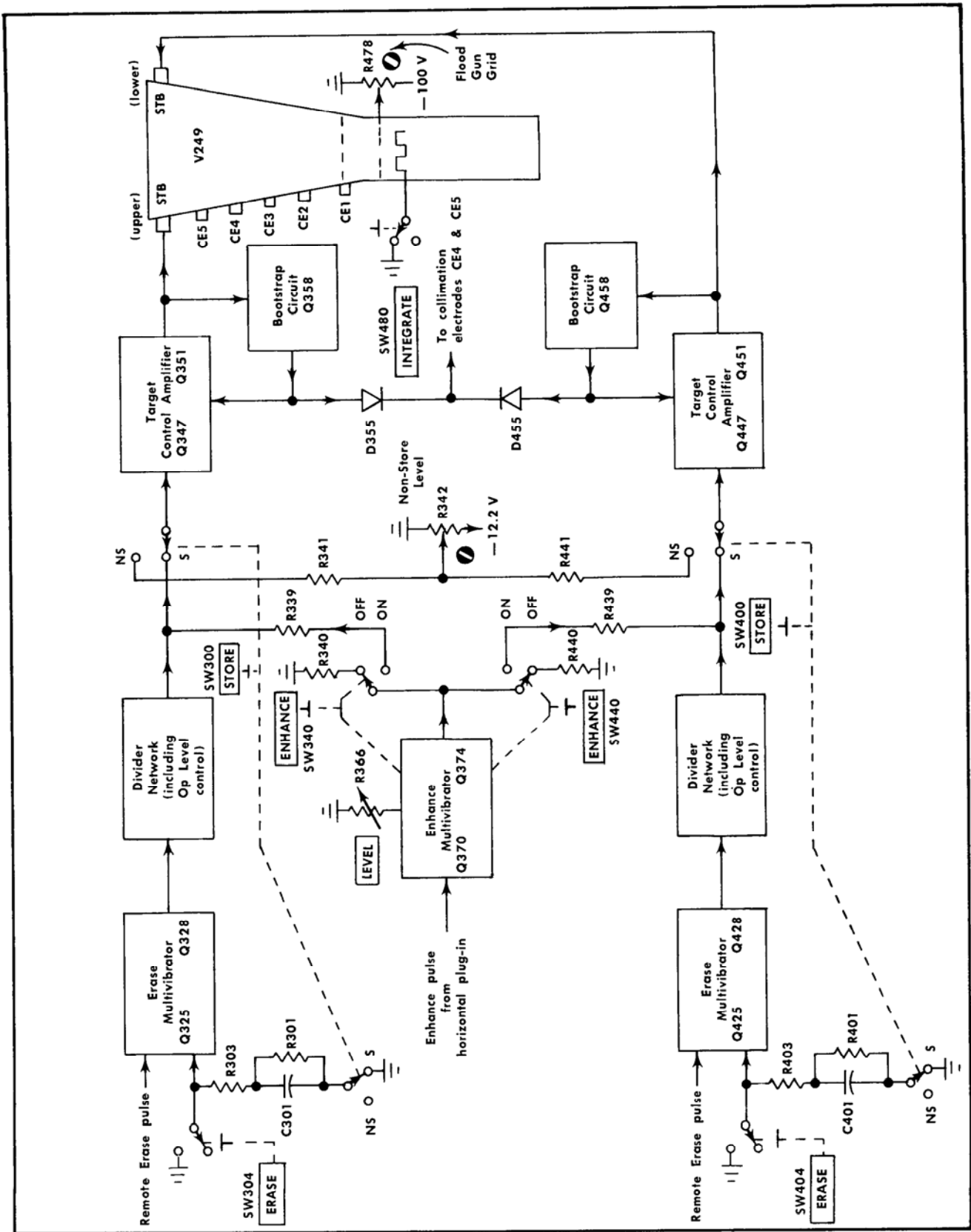

Fig. 3-5. Storage Circuit detailed block diagram.



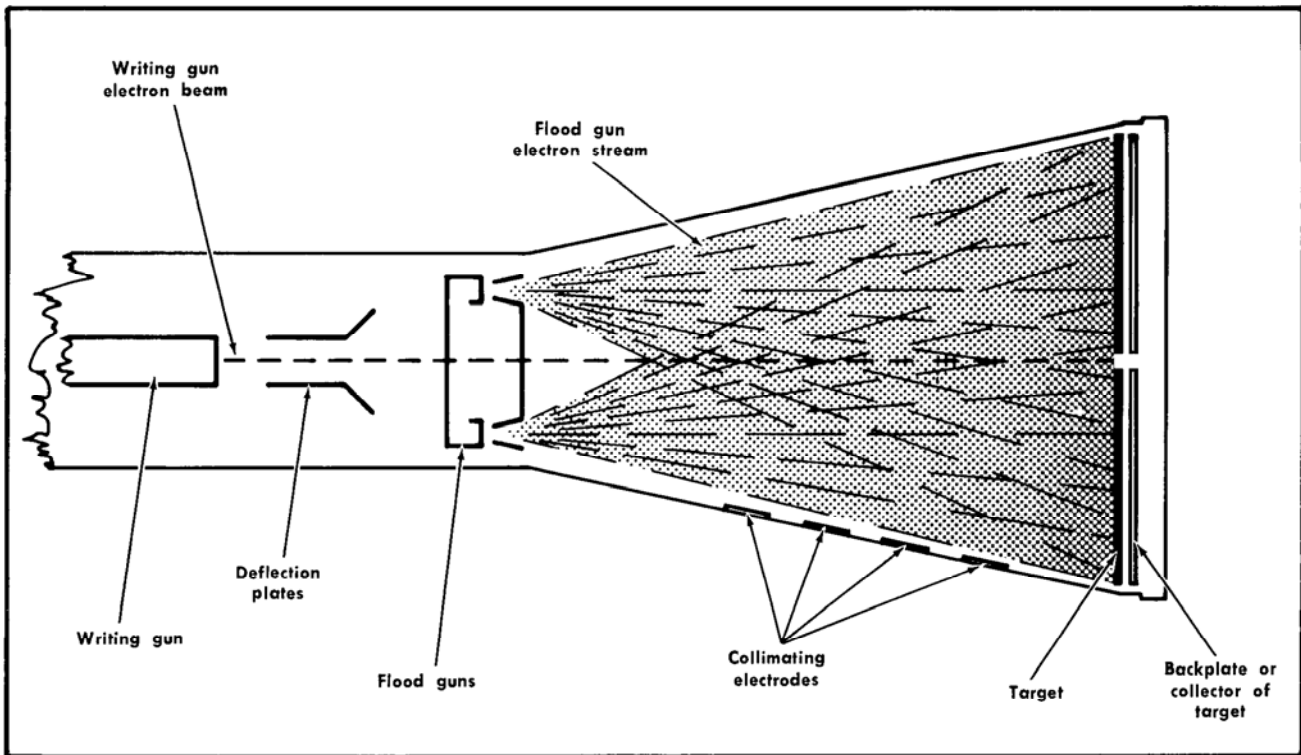

Fig. 3-6. Pictorial diagram of storage tube Type T5641.

When a multi-channel vertical plug-in amplifier that provides dual-trace chopped blanking pulses is used, the blanking pulses are applied via the interconnecting socket J11 and the CRT CATHODE SELECTOR to the CRT cathode circuit. These pulses are approximately 5 volts in amplitude, and at normal intensity levels are sufficient to cut off the CRT writing beam during the time the amplifier channels in the vertical plug-in unit are being switched.

## STORAGE CIRCUIT

### General

The Storage Circuit provides the voltage levels necessary to operate the flood guns, collimation electrodes and target backplates. The storage cathode-ray tube has two targets for split-screen operation; therefore, two identical erase generators are provided, each consisting of an Erase Multivibrator and a Target Control Amplifier. These circuits produce an erase waveform to erase written information. Additional circuitry includes the Enhance Generator, which permits very fast single sweeps to be stored, and the INTEGRATE switch, which permits a stored image of a number of repetitive sweeps, each of which would be too fast to store alone as a single sweep event. Fig. 3-5 shows a detailed block diagram of the Storage Circuit.

### Storage Tube Basic Operating Principles

The Tektronix T5641 CRT used in the Type R564B is a direct-view storage cathode ray tube with a split screen viewing area that permits each half to be individually oper-

ated for stored displays. The storage target stores electrical charges on an insulated surface by using the secondary emission properties of the surface. The stored charge is then used to control the flow of electrons to a phosphor screen to give the visual output that corresponds to the location of the stored charge.

The storage cathode ray tube contains special storage elements in addition to the conventional writing gun elements. The operating mode of the tube depends primarily on the voltages applied to these storage electrodes. With one condition of applied potentials, the storage screen or target backplate operates in the ready-to-write state; then when it is bombarded with high energy writing beam current, the bombarded portion shifts to the stored mode to store a written display. With a different set of applied voltages, the screen (target) operates in the conventional mode, similar to a conventional cathode ray tube.

The storage screens contain a special coated surface which continues to emit light when bombarded by the flood gun electrons, provided the surface has been written by the writing gun beam and shifted to the stored state. The two targets are electrically isolated from each other, which allows simultaneous presentations of stored information on one half and non-store (conventional) information on the other half of the viewing area.

Fig. 3-6 illustrates the basic construction of the T5641 storage tube. The flood guns are low-energy electron guns which direct a large area flow, or cones, of electrons toward the entire screen. The collimation electrodes shape the flood spray for uniform coverage of the storage targets. The operating level of the tube is the potential difference

## Circuit Description—Type R564B

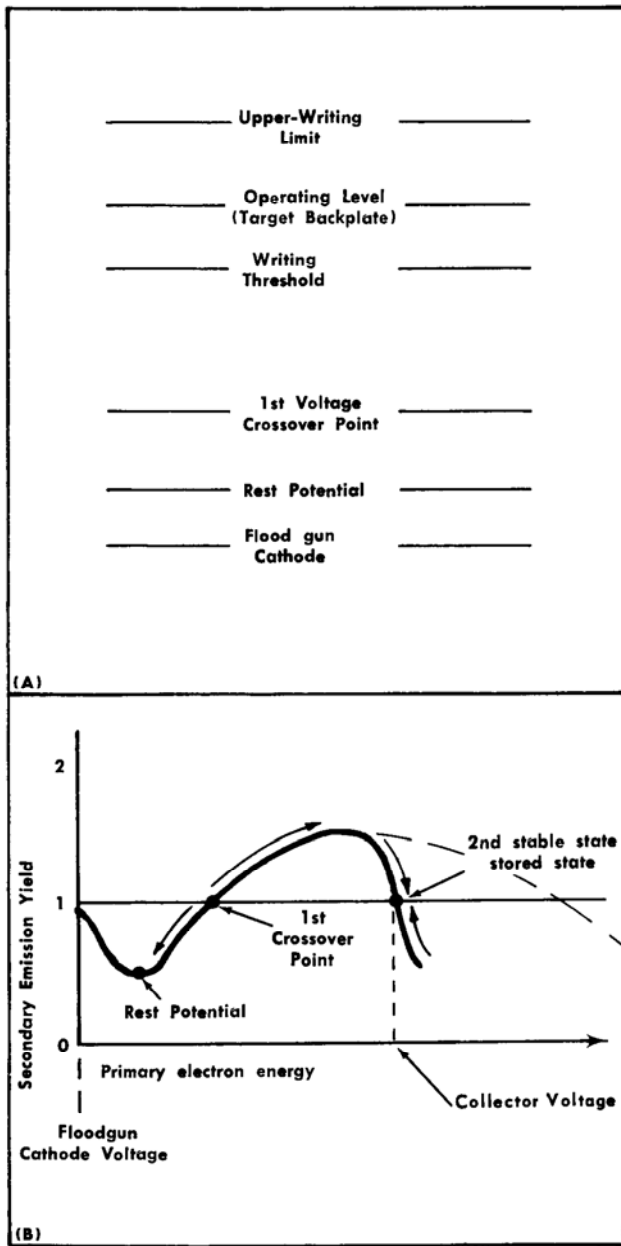

Fig. 3-7. (A) Relative scale of characteristic storage-tube operating potentials; (B) secondary emission curve for insulator showing charging direction.

between the target backplates and the flood gun cathodes. The collimation electrodes have no effect on the bombarding energy of the flood gun electrons.

In the store mode ready-to-write state the insulator surface of the target tends to charge down to a potential lower than the backplate potential, and toward the potential of the flood gun cathode. This is due to flood gun current from the insulator surface. The potential to which the target charges is called its rest potential. This potential is such that the flood gun electron landing energy is not enough to illuminate the phosphor in the target. The target is now ready to write. See Fig. 3-7.

In the writing process, the target is scanned by the writing gun electrons. These high energy electrons increase the target secondary emission over the area they scan, so that the ratio of secondary current to primary current becomes greater than one. (This is shown in Fig. 3-7B as the first crossover point.) When this ratio exceeds one, that part of the bombarded surface shifts to a new stable state. Writing has been accomplished and this segment of the target is now stored.

In the written state, the potential difference between the flood gun cathode and target becomes greater and the flood gun electrons now have a landing energy that is sufficient to provide a visual display. This visual display will continue as long as the flood gun beam covers the target.

At high sweep rates, the writing beam current is not adequate to bring the portion of the target scanned above the crossover point; therefore, the flood gun electrons when landing on the bombarded area will remove the charge developed by the writing gun electrons, and the target will discharge to its initial ready-to-write state without being written. Thus, complete writing is a function of writing beam current density.

When the stored display is no longer desired, the information is erased by a waveform as illustrated in Fig. 3-8. A positive-going pulse is first applied, to raise the backplate voltage above the writing threshold and write the entire target area with flood gun electrons. Next, the backplate voltage is pulled well below the rest potential, then as the backplate voltage is gradually returned, the target is charged to the rest potential and the target is now in the ready-to-write state.

If a comprehensive study of storage tube operating principles is desired, a Tektronix Circuit concepts paperback book entitled "Storage Cathode-Ray Tubes and Circuits" is available through your local Tektronix, Inc., Field Office or representative. Tektronix Stock No. 062-0861-00.

### Flood Guns and Collimation Electrodes

Two low-energy electron guns, or flood guns, are used in the Type R564B. The cathodes are grounded and the Flood Gun Bias control, R478, is adjusted to set the bias at approximately  $-50$  volts.

The collimation electrodes serve as an electrostatic lens to distribute the flood gun electrons uniformly over the storage target, and they have no effect on the landing energy of the electrons. CE1, CE2 and CE3 cause the flood electrons to converge, while CE4 and CE5 provide fine adjustment of the flood electron trajectories to cover the extreme rim of the targets and optimize uniformity of the target coverage. Zener diode D473 maintains a 50-volt drop to establish the  $+250$ -volt level applied to CE2, while the setting of R475, Geometry, establishes the level applied to CE1 (Flood Gun Anode). Potentiometer R470 (Collimation #1) provides a means of varying the DC levels applied to CE3 to obtain the correct electrostatic lens configuration. Voltage levels for CE4 and CE5 are established by divider network R462-R463-R465-R467. R462 (Collimation #2) is adjusted to achieve uniform luminance. The Target Control Amplifiers control CE4 and CE5 during the erase pulse so that correct collima-

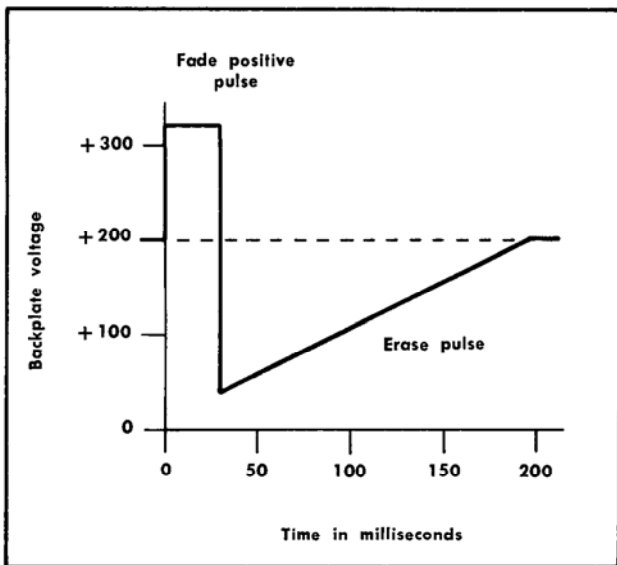

Fig. 3-8. Typical erase cycle waveform.

tion is maintained when the operating level of the tube is changed.

### Target Control Amplifiers

The Target Control Amplifiers are incorporated to maintain a high degree of control of the upper and lower storage target backplate voltages. These are emitter-follower operational amplifiers, consisting of Q347 and Q351 for the upper target backplate, and Q447 and Q451 for the lower target backplate. The amount of output accuracy is limited primarily only by the tolerances in the values of the passive elements used in the input and feedback networks. A bootstrapping circuit is provided for each Target Control Amplifier to maintain transistor operating voltage during the positive-going portion of the erase waveform (fade positive) and to provide correct collimation at the same time. The bootstrapping circuits will be described in full detail in the Erase Generator discussion.

A separate STORE switch is provided for each Target Control Amplifier, SW300 (upper) and SW400 (lower), allowing the target backplates to be operated individually. In the STORE mode (STORE switches are pushed in and the CRT is shifted to the ready-to-write state) the backplate voltages are adjusted individually by the Op Level controls, R332, and R342. These controls set the value of current to the operational amplifier null points (Q347 and Q447 bases). In the non-store, or conventional mode, the backplate voltages are established by adjustment of R342, Non-Store Level.

### Erase Generator

#### NOTE

The following description applies to both erase generators; however, the circuit numbers used are those of the upper circuit.

In order to erase the stored display, a fade-positive pulse is first applied to the storage target backplate. This increases the potential difference between the flood gun cathodes and target backplate, raising the operating level above the upper writing limit and writing the entire target area with flood gun electrons. Next, the backplate voltage is pulled negative, well below the retention threshold. Then as the backplate voltage is gradually returned, the target is charged to the rest potential and returned to the ready-to-write state. The following paragraphs describe how the erase waveform is generated.

The Erase Multivibrator is comprised of Q325, Q328 and their associated circuit components. This is a monostable multivibrator, with Q325 quiescently saturated and Q328 cut off. The collector potential of Q328 is set slightly above ground by the conduction of D329. Capacitor C323 is charged to the voltage difference between the R321-R322 juncture (about  $-9$  volts) and the Q328 collector.

When the ERASE button is pushed, the contacts of SW304 are closed, grounding R305. This produces a negative-going step which turns Q325 off and Q328 on. The collector of Q328 snaps down to about  $-12$  volts as the transistor saturates, drawing current through R338 and R353, causing the operational amplifier system to pivot about its imaginary fulcrum and pulling the target backplate positive. Thus the operating level is increased and the entire target area is written.

When Q328 turns on, the negative-going step produced at its collector is also coupled through C323, turning D322 off and ensuring cutoff of Q325. C323 begins to discharge through R321 and after an RC-controlled time of about 30 milliseconds, current through R321 has diminished sufficiently to allow the voltage at the anode of D322 to rise above the turn-on level. The base of Q325 is also raised to the turn-on level, and the multivibrator is switched back to its quiescent state.

While Q328 conducts, the charge on C330 is removed. When Q328 turns off, its collector rises rapidly and is clamped slightly above ground by D329. This produces a positive-going step which is coupled through C330, reverse biasing D330. Once again, the operational amplifier system pivots about its imaginary fulcrum, pulling the target backplate negative, well below the rest potential. As C330 charges, the voltage at the R331-R332 juncture decays from zero volts to  $-12.8$  volts at an RC-controlled rate until D330 turns on and clamps it. This negative-going sawtooth voltage is applied to the operational amplifier, which produces a positive-going sawtooth to raise the backplate to the ready-to-write state. In addition to setting the quiescent operating level of the CRT, R332 proportionately sets the amplitude of the sawtooth portion of the erase waveform. R334 and R335 then determine not only the minimum DC operating level of the CRT, but also the minimum value of the sawtooth applied to the backplate by the combined effective resistance seen at their juncture.

When the CRT is shifted from the conventional mode to the store mode, pushing the STORE button grounds C301, producing a negative trigger to switch the Erase Multivibrator and prepare the target for storage by applying an erase waveform. Remote erase function is provided through J950. A switch closure to ground or application of a negative-

## Circuit Description—Type R564B

going pulse causes differentiating network C317-R317 to produce a negative-going trigger, which is applied through D318 to the Erase Multivibrator.

Maintaining operating voltage for Q347 and Q351 during the fade-positive portion of the erase waveform, when Q351 emitter is pulled positive, is accomplished by bootstrapping. The voltage drop across Zener diode D356 sets the base of Q358 150 volts below the emitter of Q351. This voltage drop is kept constant under dynamic conditions by the essentially constant current established through R357, which is clamped by the Q358 forward bias voltage ( $V_{be}$ ). When the emitter of Q351 is suddenly stepped positive by the erase waveform, the base of Q358 is stepped positive by the same amplitude. Q358 emitter follows the base, and the positive-going step is coupled through C355 to raise the collector of Q351 positive by essentially the same amplitude as that at its emitter, thus maintaining a fairly constant collector-to-emitter voltage. This action reverse biases D350, disconnecting the +300-Volt Supply.

The positive-going pulse at Q351 collector is also connected through D355 and C462 to collimation electrodes CE4 and CE5 to provide correct collimation. When the fade positive pulse is terminated and the emitter of Q351 is pulled negative, D357 turns off, disconnecting the bootstrap circuit and allowing the collector of Q351 to return to its +300-volt level.

### Enhance Generator

Writing speed is primarily a function of the writing gun beam current density and physical properties of the storage tube. At very fast sweep speeds, the writing beam does not charge the scanned portion of the target sufficiently to shift them to the stored state, and the flood gun electrons discharge the small deposited charge back down to the rest potential before the next sweep.

Writing beyond the normal writing speed of the CRT is attained through the process of enhancement or integration. First to be discussed will be enhancement.

The enhance generator produces an approximate one-millisecond negative-going pulse which is applied to the operational amplifier summing point, resulting in a positive-going pulse to the target backplate. This conditions the target so that less writing gun current is required to shift the scanned section to the stored state.

Q370, Q374 and their associated circuitry form a monostable multivibrator. Operation of this circuit is similar to that described for the Erase Multivibrator. When either ENHANCE switch (SW340 or SW440) is pushed in, Q370 has a conduction path to ground through R370. Saturation voltage at Q370 collector holds Q374 cut off. The negative-going portion of the multi-trace sync pulse from the time-base plug-in unit is coupled through C361 to switch the Enhance Multivibrator. Q370 turns off and Q374 turns on. The collector of Q374 snaps down to about -12 volts, producing a negative-going step which turns off D368. The length of time that the multivibrator remains in this state, and thus the pulse width, is determined by the setting of R366, LEVEL, and the values of R367 and C367. The amplitude of the pulse which is applied to the operational amplifier summing point is determined by R373, Enhance (Amplitude).

### Integrate

The second fast writing technique to be discussed is integration. In this mode of operation, the flood gun beam is interrupted momentarily, allowing the writing gun beam to sum small amounts of charge for successive sweeps so that when the flood electrons are again turned on the scanned target area shifts to the stored state. This is accomplished by pressing SW480, INTEGRATE, which disconnects the flood gun cathodes from ground. This also connects a resistor into the divider network in the High Voltage Regulator circuit to shift the high voltage slightly, correcting for the deflection sensitivity changes that occur when the flood guns are turned off. Releasing the INTEGRATE switch, then, allows the display to shift to the stored state.

# SECTION 4

## MAINTENANCE

Change information, if any, affecting this section will be found at the rear of the manual.

### Introduction

This section of the manual contains information for use in preventive maintenance, corrective maintenance and troubleshooting of the Type R564B.

### Access to the Interior

The top and bottom dust covers of the Type R564B can be easily removed for access to the internal circuitry. The covers should be re-installed on the instrument for normal operation to keep dust out and provide proper distribution of the air flow.

## PREVENTIVE MAINTENANCE

### General

Preventive maintenance consists of periodic inspection and cleaning at regular intervals. The Type R564B should be checked approximately every 500 hours of operation, or every six months, whichever occurs first. If the instrument is subjected to adverse environmental conditions, such as excessive dust, high temperatures or high humidity, the frequency of the checks should be increased. A convenient time to perform preventive maintenance is preceding recalibration of the instrument.

### Cleaning

The Type R564B should be cleaned as often as operating conditions require. Accumulation of dirt in the instrument can cause overheating and component breakdown. Dirt on components acts as an insulating blanket and prevents efficient heat dissipation. It also provides an electrical conduction path.

The top and bottom covers provide protection against dust in the interior of the instrument. Operation without the covers in place necessitates more frequent cleaning.

### CAUTION

Avoid the use of chemical cleaning agents which might damage the plastics used in this instrument. Avoid chemicals which contain benzene, toluene, xylene, acetone or similar solvents.

**Exterior.** Loose dust accumulated on the outside of the Type R564B can be removed with a soft cloth or small paint brush. The paint brush is particularly useful for dislodging dirt on and around the front-panel controls. Dirt which

remains can be removed with a soft cloth dampened in a mild detergent and water solution. Abrasive cleaners should not be used.

Clean the graticule and CRT face with a soft, lint-free cloth dampened with a mild detergent and water solution.

**Interior.** Dust in the interior of the instrument should be removed occasionally due to its electrical conductivity under high-humidity conditions. The best way to clean the interior is to blow off the accumulated dust with dry, low-pressure air. Remove any dirt which remains with a soft paint brush or a cloth dampened with a mild detergent and water solution. A cotton-tipped applicator is useful for cleaning in narrow spaces and/or circuit boards.

The high voltage circuits, particularly parts located in the high-voltage compartment and the area surrounding the CRT socket should receive special attention. Excessive dirt in these areas may cause high-voltage arcing and result in improper instrument operation.

### Lubrication

The reliability of potentiometers, rotary switches and other moving parts can be maintained if they are kept properly lubricated. Use a cleaning-type lubricant (e.g., Tektronix Part No. 006-0220-00). The pot lubricant can also be used on shaft bushings. Do not over lubricate. A lubrication kit containing the necessary lubricants and instructions is available from Tektronix, Inc. Order Tektronix Part No. 003-0342-00.

**Fan Oiling.** During periodic servicing, the fan motor should be lubricated with a few drops of light machine oil (Anderol L826 available from Lehigh Company or Rotan Distributors is recommended). An industrial hypodermic needle and syringe is used to insert the oil through the rubber seal, as shown in Fig. 4-1. Hold the syringe at a 45° angle, pierce the rubber seal, then insert the needle about 1/4 inch and depress the plunger far enough to inject 3 or 4 drops of oil into the bearing. If a syringe and needle cannot be obtained locally, they may be ordered from Tektronix Inc. (Tektronix Part No. 003-0282-00 for the syringe; 003-0285-00 for the needle).

### Visual Inspection

The Type R564B should be inspected occasionally for such defects as broken connections, improperly seated transistors, damaged circuit boards and heat-damaged parts.

The corrective procedure for most visible defects is obvious; however, particular care must be taken if heat-damaged components are found. Overheating usually indicates other

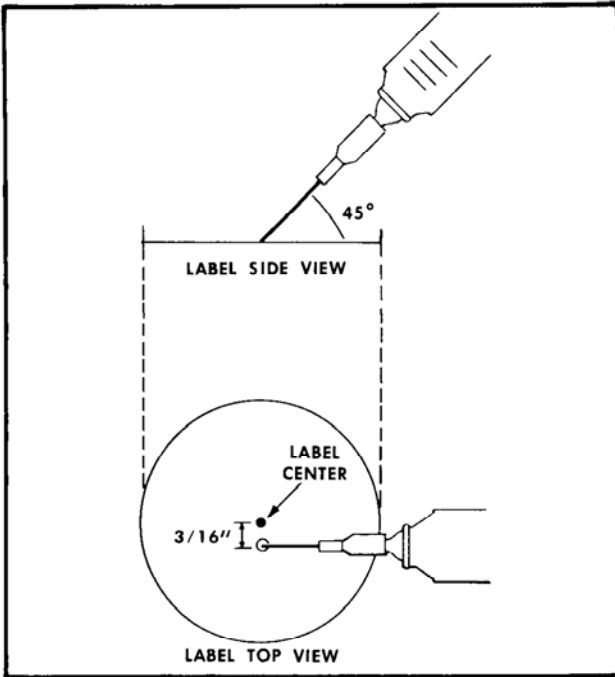

Fig. 4-1. Oiling the fan with a hypodermic.

trouble in the instrument; therefore, it is important that the cause of overheating be corrected to prevent a recurrence of the damage.

**Transistor Checks**

Periodic checks of the transistors in the Type R564B are not recommended. The best check of transistor performance is its actual operation in the instrument. More details on checking transistor operation are given under Troubleshooting.

**Recalibration**

To assure accurate measurements, check the calibration of this instrument after each 500 hours of operation or every six months if used infrequently. In addition, replacement of components may necessitate recalibration of the affected circuit. Complete calibration instructions are given in the Calibration section.

The calibration procedure can also be helpful in localizing certain troubles in the instrument. In some cases, minor troubles may be revealed and/or corrected by recalibration.

**TROUBLESHOOTING**

**Introduction**

The following information is provided to facilitate troubleshooting in the Type R564B if trouble develops. Information contained in other sections of this manual should be used along with the following information to aid in locating the defective components. When replacing a defective semiconductor, be certain that all associated components are in good condition before application of power. This precaution may prevent further damage. An understanding

of the circuit operation is very helpful in locating troubles. See the Circuit Description section for complete information.

**Troubleshooting Aids**

**Diagrams.** Circuit diagrams are given on foldout pages in Section 8. The component number and electrical value of each component in this instrument are shown on the diagrams. Each main circuit is assigned a series of component numbers. Table 4-1 lists the main circuits in the Type R564B and the series of component numbers assigned to each. Important voltages and waveforms are also shown on the diagrams at the rear of this manual. The portion of the circuit mounted on the circuit board is enclosed with a blue line.

**TABLE 4-1**  
Component Numbers

Component Numbers on Diagrams	Diagram Number	Circuit
1-99	1	Power Supply
100-110	2	Plug-in Connectors
150-199	3	1 kHz Calibrator
200-299	4	CRT Circuit
300-499	5	Storage Circuit

**Switch Wafer Identification.** Switch wafers shown on the diagrams are coded to indicate the position of the wafer in the complete switch assembly. The numbered portion of the code refers to the wafer number counting from the front, or mounting end of the switch, toward the rear. The letters F and R indicate whether the front or rear of the wafer performs the particular switching function. For example, a wafer designated 2R indicates that the rear of the second wafer (from the front) is used for this particular switching function.

**Circuit Boards.** Figs. 4-6 through 4-10 show the circuit boards used in the Type R564B. Each electrical component on each board is identified by its circuit number. The circuit board is also outlined on its schematic diagram with a blue line. These pictures used with the diagrams will aid in locating the components mounted on the circuit boards.

**Wiring Color Code.** All insulated wire and cable used in the Type R564B is color-coded to facilitate circuit tracing. Signal carrying leads are identified with three stripes to indicate the approximate voltage, using the EIA resistor color code. A white background color indicates a positive voltage and a tan background indicates a negative voltage. The widest color stripe identifies the first color of the code. Table 4-2 gives the wiring color code for the power supply voltages used in the Type R564B.

**TABLE 4-2**  
Power Supply Wiring Color Code

Supply	Background Color	First Stripe	Second Stripe	Third Stripe
+300 V	White	Orange	Black	Brown
+125 V	White	Brown	Red	Brown
-12.2 V	Tan	Brown	Red	Black
-100 V	Tan	Brown	Black	Brown

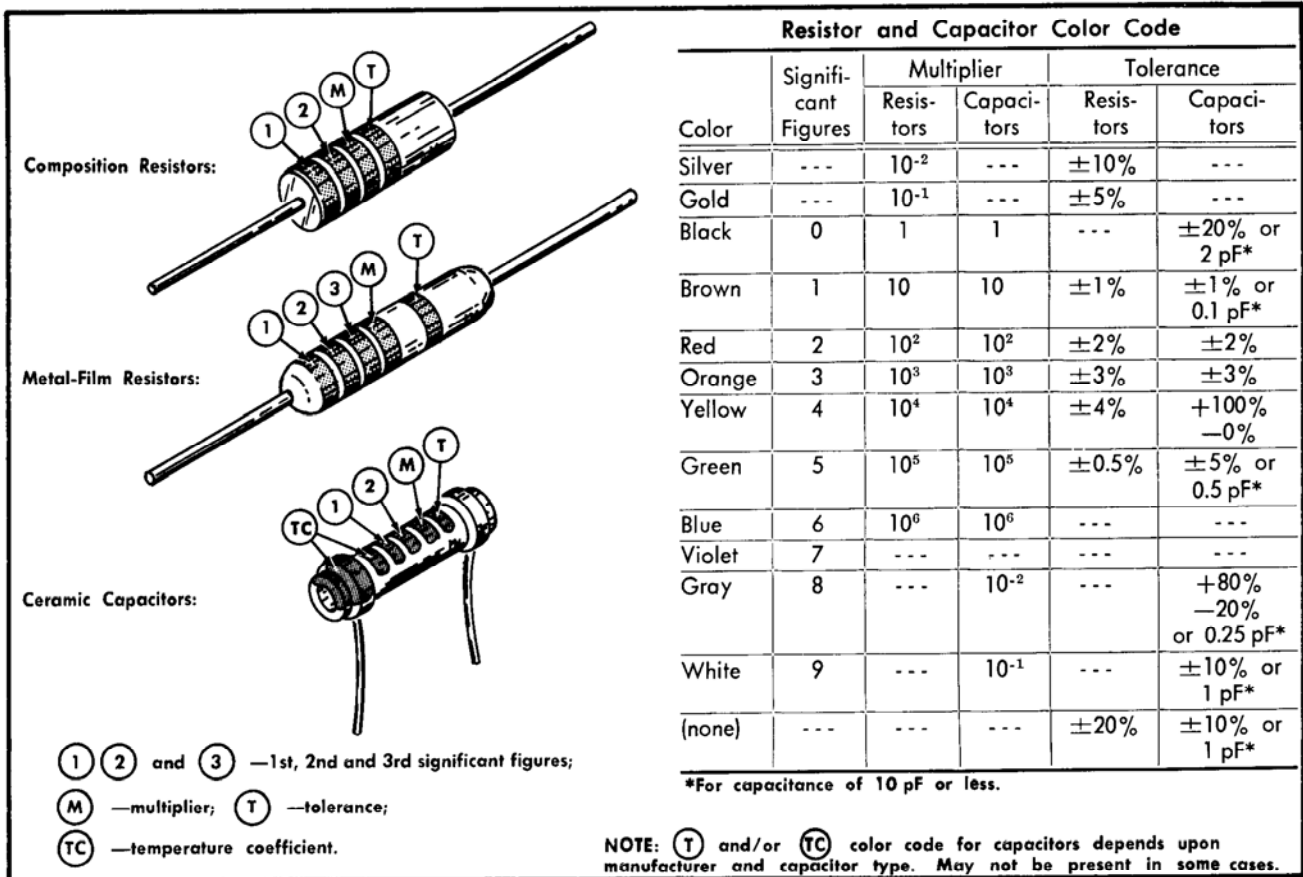

Fig. 4-2. Standard EIA color coding for resistors and capacitors.

**Resistor Color Code.** In addition to the brown composition resistors, some metal-film resistors and some wire-wound resistors are used in the Type R564B. The resistance values of wire-wound resistors are printed on the body of the component. The resistance values of composition resistors and metal-film resistors are color-coded on the components with EIA color code (some metal-film resistors may have the value printed on the body). The color code is read starting with the stripe nearest the end of the resistor. Composition resistors have four stripes which consist of two significant figures, a multiplier and a tolerance value (see Fig. 4-2). Metal-film resistors have five stripes consisting of three significant figures, a multiplier and a tolerance value.

**Capacitor Marking.** The capacitance values of common disc capacitors and small electrolytics are marked in microfarads on the side of the component body. The white ceramic capacitors used in the Type R564B are color coded in picofarads using a modified EIA color code (see Fig. 4-2).

**Diode Color Code.** The cathode end of a glass-enclosed diode is indicated by a stripe, a series of stripes or a dot. For most silicon or germanium diodes with a series of stripes, the color code identifies the three significant digits of the Tektronix Part Number using the resistor color-code system (e.g., a diode color-coded blue-brown-gray-green (6, 1, 8, 5) indicates Tektronix Part Number 152-0185-00). The cathode and anode ends of metal diodes can be identified by the diode symbol marked on the body.

### Troubleshooting Equipment

The following equipment is useful for troubleshooting the Type R564B:

1. Transistor Tester

Description: Tektronix Type 575 Transistor Curve Tracer or equivalent.

Purpose: To test the semiconductors used in this instrument.

2. Multimeter

Description: Electronic Voltmeter, 10 megohms, or greater, input resistance; 0 to 500 volts; 0 to 50 megohms. Accuracy, within 3% (1% is necessary to check power supply voltages). Test prods must be insulated to prevent accidental shorting.

Purpose: To check operating voltages and for general troubleshooting in this instrument.

NOTE

A 20,000 ohms/volt VOM can be used to check the voltages in this instrument if allowances are made for the circuit loading of the VOM at high impedance points.

## Maintenance—Type R564B

### 3. Test Oscilloscope (with 1× and 10× probes).

Description: DC to 1 MHz frequency response, 1 millivolt to 10 volts/division deflection factor.

Purpose: To check waveforms in the instrument.

## Troubleshooting Techniques

This troubleshooting procedure is arranged in an order which checks the simple trouble possibilities before proceeding with the extensive troubleshooting. The first few checks assure proper connection, operation and calibration. If the trouble is located by these checks, the remaining steps aid in locating the defective component. When the defective component is located, it should be replaced following the replacement procedures given under Corrective Maintenance.

**1. Check Control Settings.** Incorrect control settings can indicate a trouble that does not exist. If there is any question about the correct function or operation of any control, see the Operating Instructions section of the manual.

**2. Check Associated Equipment.** Before proceeding with troubleshooting of the Type R564B, check that the equipment used with this instrument is operating correctly. Substitute another vertical or time-base plug-in which is known to be operating properly. Check that the signal is properly connected and that interconnecting cables are not defective. Also, check the power source.

**3. Visual Check.** Visually check the portion of the instrument in which the trouble is located or suspected. Many troubles can be located by visual indications such as unsoldered connections, broken wire, damaged circuit boards, damaged components, etc.

**4. Check Instrument Calibration.** Check the calibration of this instrument, or the affected circuit if the trouble exists in one circuit. The apparent trouble may only be a result of misadjustments or may be corrected by calibration. Complete calibration instructions are given in the Calibration section of this manual.

**5. Isolate Trouble to a Circuit.** To isolate trouble to a circuit, note the trouble symptom. The symptom often identifies the circuit in which the trouble is located. For example, poor focus indicates that the CRT circuit (includes high voltages) is probably at fault. When trouble symptoms appear in more than one circuit, check affected circuits by taking voltage and waveform readings.

Incorrect operation of all circuits often indicates trouble in the power supplies. However, a defective component elsewhere in the instrument can appear as a power supply trouble and may also affect the operation of other circuits.

### NOTE

Turn the instrument off before attempting to remove or replace connections to any circuit board.

Table 4-3 lists the tolerances of the power supplies in this instrument. If a power supply voltage is within the listed tolerance, the supply can be assumed to be working correctly. If outside the tolerance, the supply may be misadjusted or operating incorrectly. Use the procedure given in the Calibration section to adjust the power supplies.

TABLE 4-3

Power Supply Tolerances

Power Supply	Tolerance
−3300 V	Within 3%
−100 V	Within 0.5%
−12.2 V	Within 1.2%
+125 V	Within 1.5%
+300 V	Within 1.5%

**6. Check Circuit Board Interconnections.** After the trouble has been isolated to a particular circuit, check the pin connectors on the circuit board for correct connection. Figs. 4-6 through 4-10 show the correct connections for each board.

The pin connectors used in this instrument also provide a convenient means of circuit isolation. For example, a short circuit in a power supply can be isolated to the power supply itself by disconnecting the pin connectors for that voltage at the remaining boards.

**7. Check Voltages and Waveforms.** Often the defective component can be located by checking for correct voltage or waveforms in the circuit. Ideal voltages are given on the diagrams.

### NOTE

Voltages given on the diagrams are calculated with the assumption that conditions are ideal (variable components at design center, etc.), and may vary slightly from actual measured voltages.

**8. Check Individual Components.** The following procedures describe methods of checking the individual components in the Type R564B. Components which are soldered in place are best checked by disconnecting one end. This isolates the measurement from the effects of surrounding circuitry.

**A. TRANSISTORS.** The best check of transistor operation is actual performance under operating conditions. If a transistor is suspected of being defective, it can best be checked by substituting a new component or one which has been checked previously. However, be sure that circuit conditions are not such that a replacement transistor might also be damaged. If substitute transistors are not available, use a dynamic tester (such as Tektronix Type 575). Static type testers may be used, but since they do not check operation under simulated operating conditions some defects may go unnoticed. Fig. 4-3 shows transistor base pin and socket arrangements. Be sure power is off before attempting to remove or replace any transistor.

**B. DIODES.** A diode can be checked for an open or shorted condition by measuring the resistance between terminals. With an ohmmeter scale having an internal source of between 800 millivolts and 3 volts, the resistance should be high in one direction and low when the leads are reversed.

**C. RESISTORS.** Check the resistors with an ohmmeter. See the Electrical Parts List for the tolerance of the resistors used in this instrument. Resistors normally need not be replaced unless the measured value varies widely from the specified value.



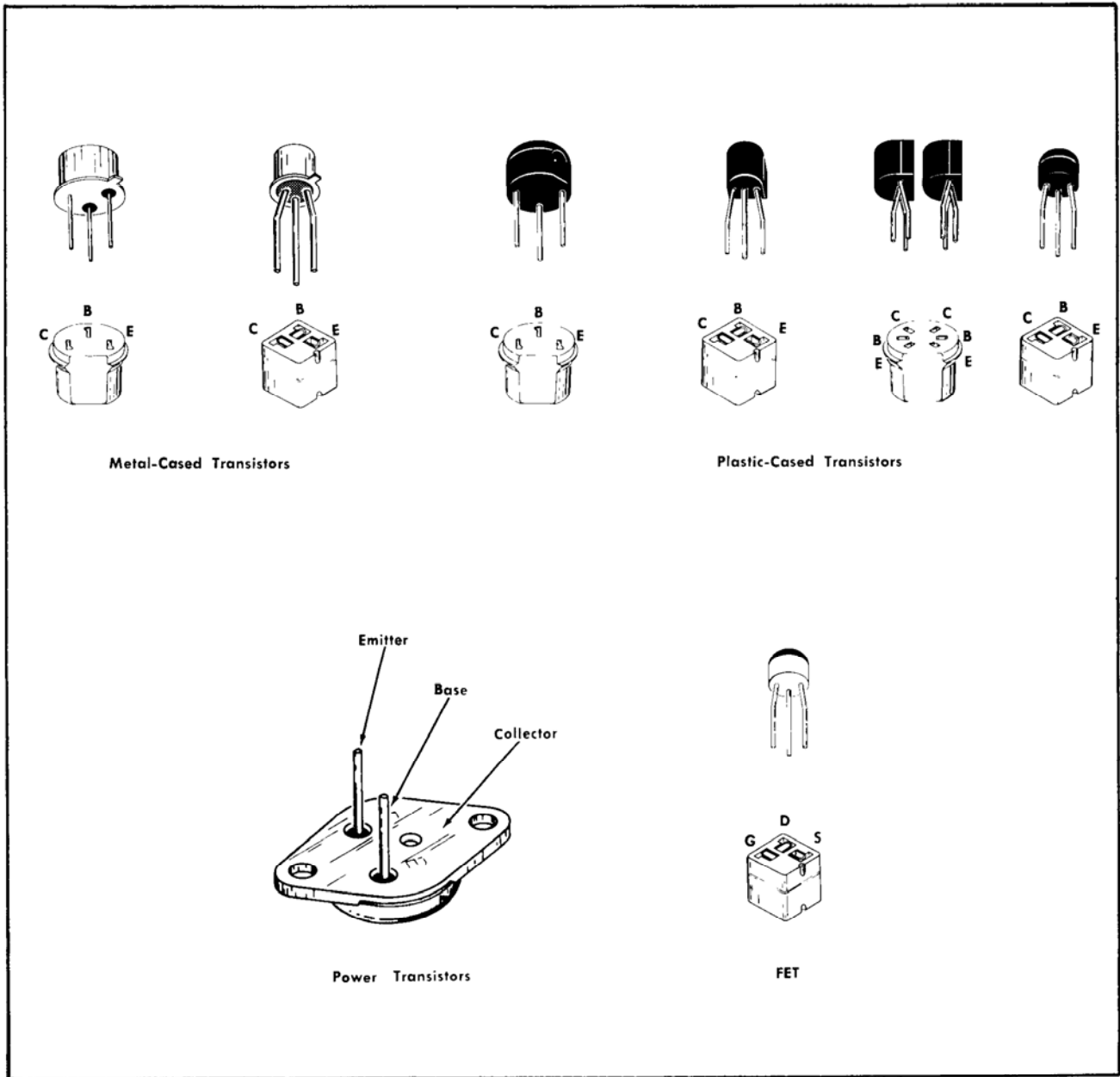

Fig. 4-3. Transistor electrode configuration data.

D. CAPACITORS. A leaky or shorted capacitor can be determined by checking resistance with an ohmmeter on the highest scale. Use an ohmmeter which will not exceed the voltage rating of the capacitor. The resistance reading should be high after initial charge of the capacitor. An open capacitor can best be detected with a capacitance meter, or by checking whether the capacitor passes AC signals.

**9. Troubleshooting in the Low Voltage Power Supplies.** The low voltage supplies incorporate special circuitry to prevent damage due to short circuits on the voltage

output lines. When this circuitry is operating properly, the low voltage supplies are extremely reliable. If any trouble occurs in the low-voltage power supply (Diagram 1), be certain that all defective components are replaced before re-application of power. Otherwise uncorrected problems could cause further damage including damage to the new component. Although not every situation can be predicted, such occurrences will be unlikely if the following precautions are taken.

A. Turn the power off.

B. If the problem is possibly in the -100-, +125- or +300-

## Maintenance—Type R564B

volt supplies, visually check current-sensing resistors R33, R75 and R94 for charring or cracking. For location of components, refer to Fig. 4-6.

C. Check current-sensing transistors Q30, Q38, Q70 and Q91 on a transistor checker.

D. If a current-sensing resistor or transistor has failed, check all remaining diodes and transistors in the corresponding section of circuitry (see Table 4-4). Most of the diodes mentioned can be checked in the circuit using an ohmmeter.

**TABLE 4-4**

Component Failure	Check
Q38	D35A, D35B, D47, Q44, Q46, Q49 Q51
Q30 or R33	D8A, D8B, D8C, D8D, D19, D25, D31, Q12, Q14, Q24, Q28, Q30, Q32
Q70, Q91, R75 or R94	D53A, D53B, D53C, D53D, D62, D65, D75, D76, D77A, D77B, D77C, D77D, D80, D95, Q58, Q60, Q66, Q68, Q74, Q84, Q86, Q88, Q90, Q96

E. Make a careful visual check of R8, R52, R53, R61, R69, R77 and R87 for charring or cracks.

F. Re-apply the power. If a line-voltage autotransformer is available, gradually increase the line voltage from zero volts to 115 volts (or to the center of the regulating range to which the Voltage Selector Assembly is set) while monitoring the output of the low-voltage supply.

**10. Repair and Readjust the Circuit.** If any defective parts are located, follow the corrective maintenance procedures given in this section. Be sure to check the performance of any circuit that has been repaired or that has had any electrical components replaced.

## CORRECTIVE MAINTENANCE

### General

Corrective maintenance consists of component replacement and instrument repair. Special techniques required to replace components in this instrument are given here.

### Obtaining Replacement Parts

**Standard Parts.** All electrical and mechanical part replacements for the Type R564B can be obtained through your local Tektronix Field Office or representative. However, many of the standard electronic components can be obtained locally in less time than is required to order them from Tektronix, Inc. Before purchasing or ordering replacement parts, check the parts lists for value tolerance, rating and description.

#### NOTE

When selecting replacement parts, it is important to remember that the physical size and shape of the component may affect its performance in the instrument. All replacement parts should be direct

replacements unless it is known that a different component will not adversely affect instrument performance.

**Special Parts.** In addition to the standard electronic components, some special parts are used in the Type R564B. These parts are manufactured for Tektronix, Inc. in accordance with our specifications. These special parts are indicated in the parts lists by an asterisk preceding the part number. Most of the mechanical parts used in this instrument have been manufactured by Tektronix, Inc. Order all special parts directly from your local Tektronix Field Office or representative.

**Ordering Parts.** When ordering replacement parts from Tektronix, Inc., include the following information:

1. Instrument Type.
2. Instrument Serial Number.
3. A description of the part (if electrical, include the circuit number).
4. Tektronix Part Number.

## Soldering Techniques

### WARNING

Disconnect the instrument from the power source before soldering.

**Circuit Boards.** Use ordinary 60/40 solder and a 35 to 40 watt pencil-type soldering iron on the circuit boards. The tip of the iron should be clean and properly tinned for best heat transfer to the solder joint. A higher wattage iron may separate the wiring from the base material.

The following technique should be used to replace a component without removing the boards from the instrument.

1. Grip the component lead with long-nose pliers. Touch the soldering iron tip to the lead at the solder connection. Do not lay the iron directly on the board as it may damage the board. See Fig. 4-4.

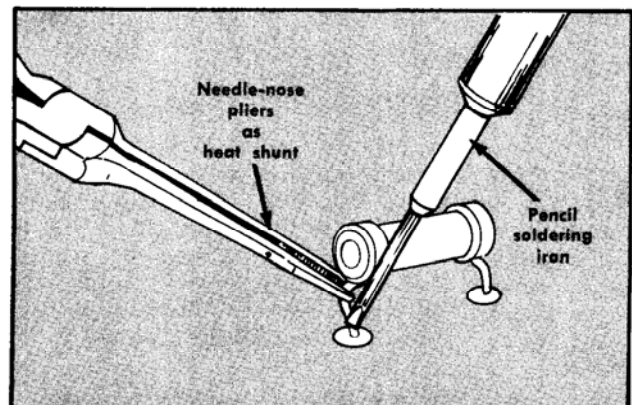

Fig. 4-4. Removing or replacing component on circuit board.

2. When the solder begins to melt, pull the lead out gently. This should leave a clean hole in the board. If not, the hole can be cleaned by reheating the solder and placing a sharp object such as a toothpick into the hole to clean it out.

3. Bend the leads of the new component to fit the holes in the board. Insert the leads into the holes in the board so the component is firmly seated against the board (or as positioned originally). If it does not seat properly, heat the solder and gently press the component into place.

4. Touch the iron to the connection and apply a small amount of solder to make a firm solder joint. To protect heat-sensitive components, hold the lead between the component body and solder joint with a pair of long-nose pliers or other heat sink.

5. Clip the excess lead that protrudes through the board (if not clipped in step 3).

6. Clean the area around the solder connection with a flux-remover solvent. Be careful not to remove information printed on the board.

**Metal Terminals.** When soldering metal terminals (e.g., switch terminals, potentiometers, etc.) ordinary 60/40 solder can be used. Use a soldering iron with a 40 to 75 watt rating and a  $\frac{1}{8}$ -inch wide wedge-shaped tip.

Observe the following precautions when soldering metal terminals:

1. Apply heat only long enough to make the solder flow freely.
2. Apply only enough solder to form a solid connection. Excess solder may impair the function of the part.
3. If a wire extends beyond the solder joint, clip off the excess.
4. Clean the flux from the solder joint with a flux-remover solvent.

## Component Replacement

### WARNING

Disconnect the instrument from the power source before replacing components.

**Ceramic Terminal Strip Replacement.** A complete ceramic terminal strip assembly is shown in Fig. 4-5. Replacement strips (including studs) and spacers are supplied under separate part numbers. However, the old spacers may be re-used if they are not damaged. The applicable Tektronix Part Number for the ceramic strips and spacers used in this instrument are given in the Mechanical Parts List.

To replace a ceramic terminal strip, use the following procedure:

#### REMOVAL:

1. Unsolder all components and connections on the strip. To aid in replacing the strip, it may be advisable to mark each lead or draw a sketch to show location of the components and connections.

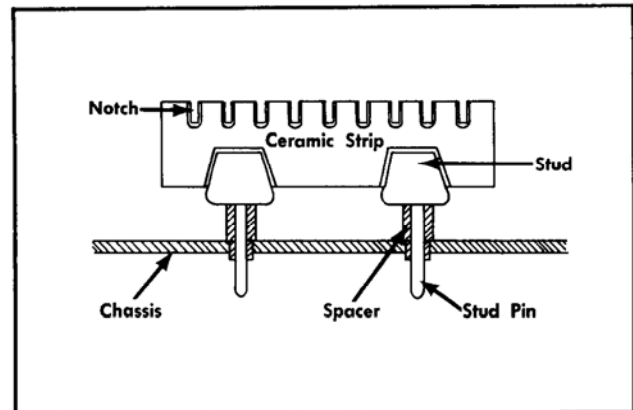

Fig. 4-5. Ceramic terminal strip assembly.

2. Pry or pull the damaged strip from the chassis. Be careful not to damage the chassis.

3. If the spacers come out with the strip, remove them from the stud pins for use on the new strip (spacers should be replaced if they are damaged).

#### REPLACEMENT:

1. Place the spacers in the chassis holes.
2. Carefully press the studs of the strip into the spacers until they are completely seated.
3. If the stud extends through the spacers, cut off the excess.
4. Replace all components and connections. Observe the soldering precautions given under Soldering Techniques in this section.

**Circuit Board Replacement.** If a circuit board is damaged beyond repair, either the entire assembly including all soldered-on components, or the board only, can be replaced. Part numbers are given in the Mechanical Parts List for either the completely wired or the unwired board. Many of the components mounted on the circuit boards can be replaced without removing the boards from the instrument. Observe the soldering precautions given under Soldering Techniques in this section. However, if the bottom side of the board must be reached or if the board must be moved to gain access to other areas of the instrument, the mounting screws need to be removed it may be necessary to disconnect some of the interconnecting wires from the pin connectors. Refer to Figs. 4-6 through 4-10 for component locations and interconnecting wire identifying colors.

#### GENERAL:

Most of the connections to the circuit boards are made with pin connectors. However, the connections to the switch interface boards and the connections to the High Voltage circuit boards are soldered. See the special removal instructions to remove these boards as units.

Use the following procedure to remove a circuit board.

1. Disconnect all the pin connectors.

## Maintenance—Type R564B

2. Remove all screws that hold the board to the chassis.
3. Lift the board out of the instrument. Do not force or bend the board.
4. To replace the board, reverse the order of removal. Replace the pin connectors carefully so they mate correctly with the pins. If forced into place incorrectly positioned, the pin connectors may be damaged.

### SWITCH INTERFACE BOARD REMOVAL:

1. Remove the Storage board.
2. Remove the four machine screws (with nuts and washers) holding the boards to the mounting bracket.
3. Carefully slide the board and switch assembly away from the subpanel until it can be lifted out of the instrument.
4. Unsolder the interconnecting wire straps between the two boards. Observe soldering precautions given earlier.
5. With the two boards separated, either board can now be unsoldered from the cable harness to completely detach it from the instrument.
6. To replace the boards, reverse the order of removal.

### HIGH VOLTAGE BOARD REMOVAL:

1. Remove the metal high-voltage shield (it is secured to the chassis by two nuts on the opposite side of the chassis).
2. Remove the plastic cover on the high-voltage compartment (it is held in place with three screws).
3. Unsolder the two diodes connected between the board and the high-voltage transformer. Extra care should be used to avoid damaging the plastic compartment with the soldering iron.
4. Ease the board assembly out of the plastic compartment, while unsoldering the wires on the side nearest the transformer. Unsolder other wires as necessary until the entire assembly can be removed as a unit.
5. To replace the boards, reverse the order of removal.

**Fan Assembly Replacement.** The fan assembly may be removed from its snap-in mounting using the following procedure:

1. Pry off the snap-in protective grille.
2. From the interior of the instrument, depress the holding clip on one side by inserting a small screwdriver or other tool between the fan assembly and the clip. While the clip is depressed, pull the fan toward the rear with the other hand until it is clear of the holding fingers (about 1/2 inch). At this stage, the fan assembly should be tilted from the centerline since the fingers on the opposite clip will still be engaged.
3. Depress the opposite holding clip while pulling the fan assembly to the rear. When the fan assembly is free of the holding fingers of both clips, it may be pulled free of the snap-in mounting to the length of the power leads.
4. To completely disconnect the fan assembly from the instrument, unsolder the two power leads.
5. To replace the fan, reverse the order of removal. Very little pressure is required to properly seat the fan assembly

in the holding clips, provided the alignment is correct. To assure proper alignment, observe that the upper and lower ends of the holding clips are curved inward to form flanges and that the side of the fan assembly are grooved to accept the flanges when alignment is correct.

**Cathode-Ray Tube Replacement.** The following procedure outlines the removal and replacement of the cathode-ray tube:

### REMOVAL:

1. Remove the bezel (held in place with four knurled nuts) and the graticule light shield. Also remove any filters that may be in front of the graticule.
2. Disconnect the deflection-plate leads. Be careful not to bend the deflection-plate pins.
3. Remove the fan assembly as outlined in the preceding paragraphs.
4. Remove the CRT base socket.
5. Loosen the three screws on the CRT clamp inside the CRT shield (base end). Do not remove the screws. (One of these screws is for the clamp; the other two permit positioning of the clamp).
6. Pushing on the CRT base, slide the CRT forward. Pull the CRT out of the instrument from the front. Be sure that the CRT neckpins clear the shield edge as the CRT is pushed out.

### WARNING

High vacuum cathode ray tubes are dangerous to handle. To prevent personnel injury from flying glass in case of tube breakage, wear a face mask or safety goggles, and gloves.

Handle the CRT with extreme care. Do not strike or scratch it. Never subject it to more than moderate force or pressure when removing or installing. Always store spare CRT's in original protective cartons. Save cartons to dispose of used CRT's.

7. Remove the boot (shockmounting gasket) and graticule from the CRT faceplate.

### REPLACEMENT:

1. Make sure the faceplate and graticule are clean, then place the graticule on the faceplate (with the etched graticul lines against the faceplate). Place the boot around the CRT faceplate and graticule such that the two tabs on the graticule extend through the two slots in the boot, and the graticule is held firmly against the faceplate.
2. Check that the CRT base pins are straight (make a test installation of the CRT base socket onto the base pins outside the instrument), then insert the CRT into the shield. Guide the CRT base into the clamp and slide the CRT toward the rear of the instrument.
3. Tighten the clamp screw inside the CRT shield, leaving the two positioning screws loose. Recommended tightening torque: 4 to 7 inch-pounds.
4. Align the CRT faceplate square with the front of the instrument by positioning the CRT base. Tighten the two positioning screws.

**TABLE 4-5**  
Fuse Ratings

Circuit Number	Rating	Location	Function
F1	3.2 A Slo-blow	Line Voltage Selector assembly	115-volt line
F2	2 A Slo-blow	Line Voltage Selector assembly	230-volt line
F9	0.15 A Fast-blow	Low Voltage Power Supply circuit board	High Voltage

5. Replace the light shield, filter (if used), bezel and securing nuts.

6. Place the CRT base socket onto the CRT base pins.

7. Replace the deflection-plate pin connectors. Correct location is indicated on the CRT shield.

8. Replace the fan assembly.

9. Replacing the CRT will require instrument recalibration. Refer to Calibration, Section 5.

**Scale Illumination Lamp Replacement.** The procedure is as follows:

1. Remove the CRT bezel (held in place with four knurled nuts) and the graticule light shield. Also remove any filters that may be in front of the graticule.

2. Remove the Storage board to gain access to the lamp sockets.

3. Loosen the nut holding the adjustable lamp-socket bracket and slide the bracket forward through the front panel as far as possible.

4. Remove the defective lamp by pulling straight out with the fingers.

5. Insert the new lamp. Be sure it is pushed all the way into the socket.

6. Adjust the lamp-socket bracket for proper protrusion through the front panel. It must not extend beyond the light shield.

7. Replace the Storage board, filters (if any) and bezel.

**Transistor Replacement.** Transistors should not be replaced unless they are actually defective. If removed from their sockets during routine maintenance, return them to their original sockets. Unnecessary replacement or switching of components may affect the calibration of the instrument. When a transistor is replaced, check the operation of that part of the instrument which may be affected.

Any replacement component should be of the original type or a direct replacement. Re-mount the components in the same manner as the original. Fig. 4-3 shows the lead configurations of the transistors used in this instrument.

Transistors which are mounted on the heat sink on the rear panel use a special thermal-joint compound to increase heat transfer. Replace the compound when replacing these transistors.

#### WARNING

If silicone grease is used as a thermal-joint compound handle the silicone grease with care. Avoid

getting silicone grease in the eyes. Wash hands thoroughly after use.

**Fuse Replacement.** Table 4-5 gives the rating, location and function of the fuses used in this instrument.

**Rotary Switches.** Individual wafers or mechanical parts of rotary switches are normally not replaceable. If a switch is defective, replace the entire assembly. Replacement switches can be ordered either wired or unwired; refer to the Parts List for the applicable part numbers.

When replacing a switch, tag the switch terminals and leads with corresponding identification tags as a guide for installing the new switch. An alternate method is to draw a sketch of the switch layout and record the wire color at each terminal. When soldering to the new switch, be careful that the solder does not flow beyond the rivets on the switch terminal. Spring tension of the switch contact can be destroyed by excessive solder.

**Power Transformer Replacement.** The power transformer in this instrument is warranted for the life of the instrument. If the power transformer becomes defective, contact your local Tektronix Field Office or representative for a warranty replacement (see the Warranty note in the front of this manual). Be sure to replace only with a direct replacement Tektronix transformer.

When removing the transformer, tag the leads with the corresponding terminal numbers to aid in connecting the new transformer. After the transformer is replaced, check the performance of the complete instrument using the Performance Check instructions outlined in Section 5, Calibration.

**High-Voltage Compartment.** The components located in the high-voltage compartment can be reached for maintenance or replacement by using the following procedure.

1. Remove the metal high-voltage shield by removing the two hexagonal nuts on the opposite side of the chassis.

2. Remove the plastic cover (held in place with three screws).

3. To remove the complete wiring assembly from the high-voltage compartment, first unsolder the two diodes connected between the board assembly and the high-voltage transformer and then lift the board assembly out far enough to unsolder the leads connecting to the side of the assembly closest to the transformer. Unsolder other leads as necessary to allow the board assembly to be lifted free of the instrument.

4. To remove the high-voltage transformer, unsolder the leads connecting to the pins on the top of the transformer.

## **Maintenance—Type R564B**

5. To replace the high-voltage compartment, reverse the order of removal.

### **NOTE**

All solder joints in the high-voltage compartment should have smooth surfaces. Any protrusions may cause high-voltage arcing at high altitudes.

### **Recalibration After Repair**

After any electrical component has been replaced, the

calibration of that particular circuit should be checked, as well as the calibration of other closely related circuits. Since the low-voltage supply affects all circuits, calibration of the entire instrument should be checked if work has been done in the low-voltage power supply or if the power transformer has been replaced. The Performance Check instructions outlined in Section 5 provide a quick and convenient means of checking the instrument operation.

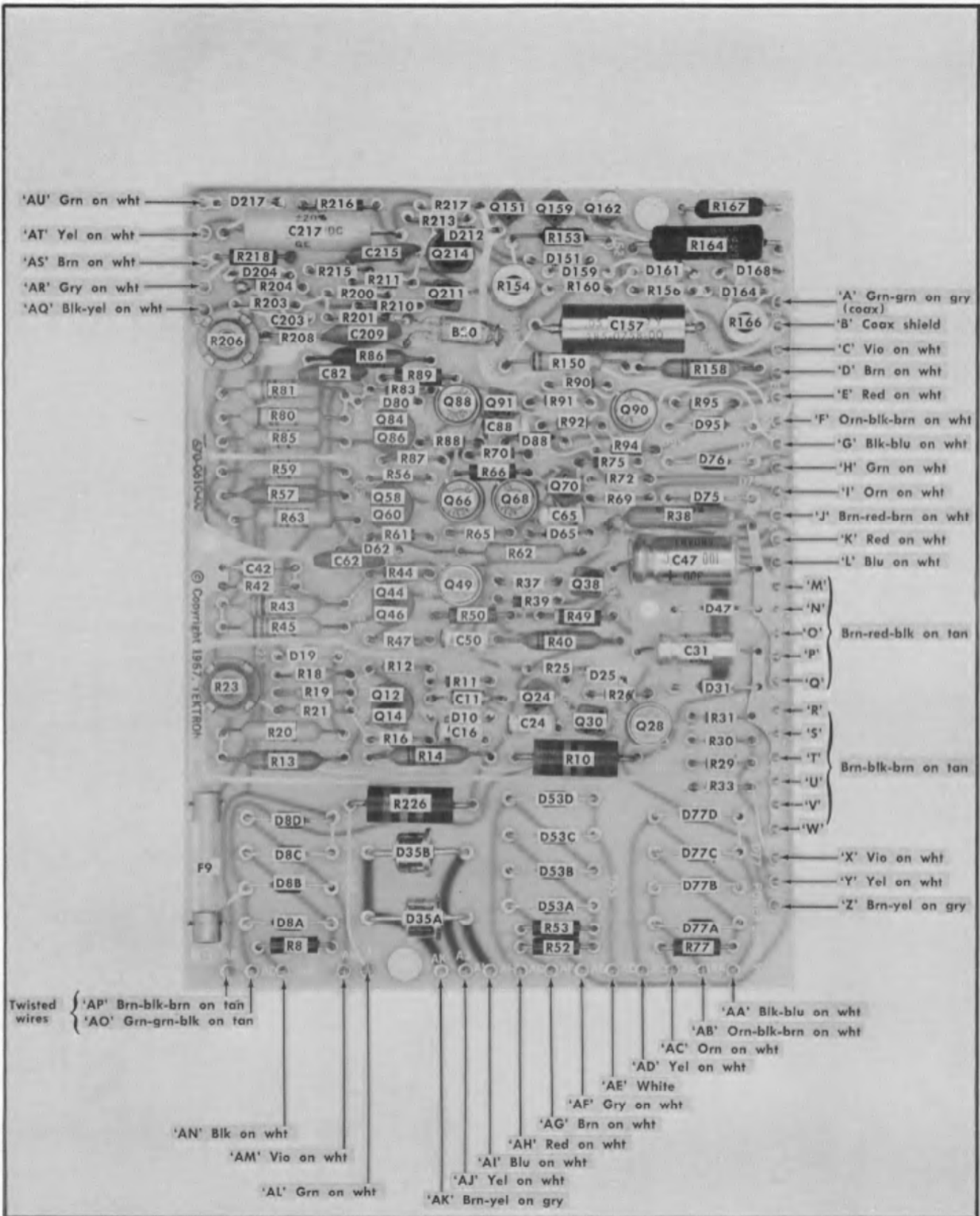

Fig. 4-6. Low Voltage Power Supply and 1 kHz Calibrator circuit board.

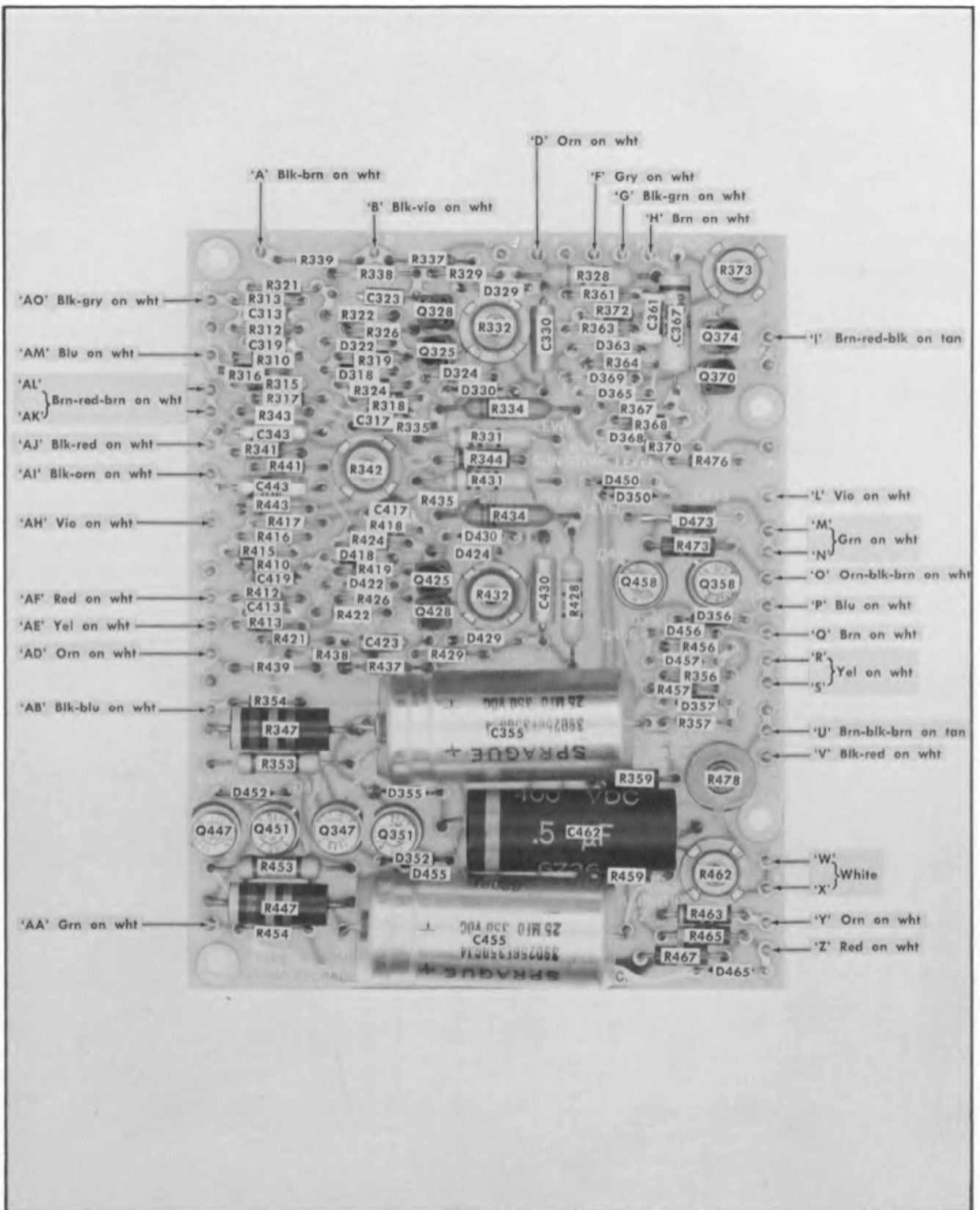

Fig. 4-7. Storage circuit board.



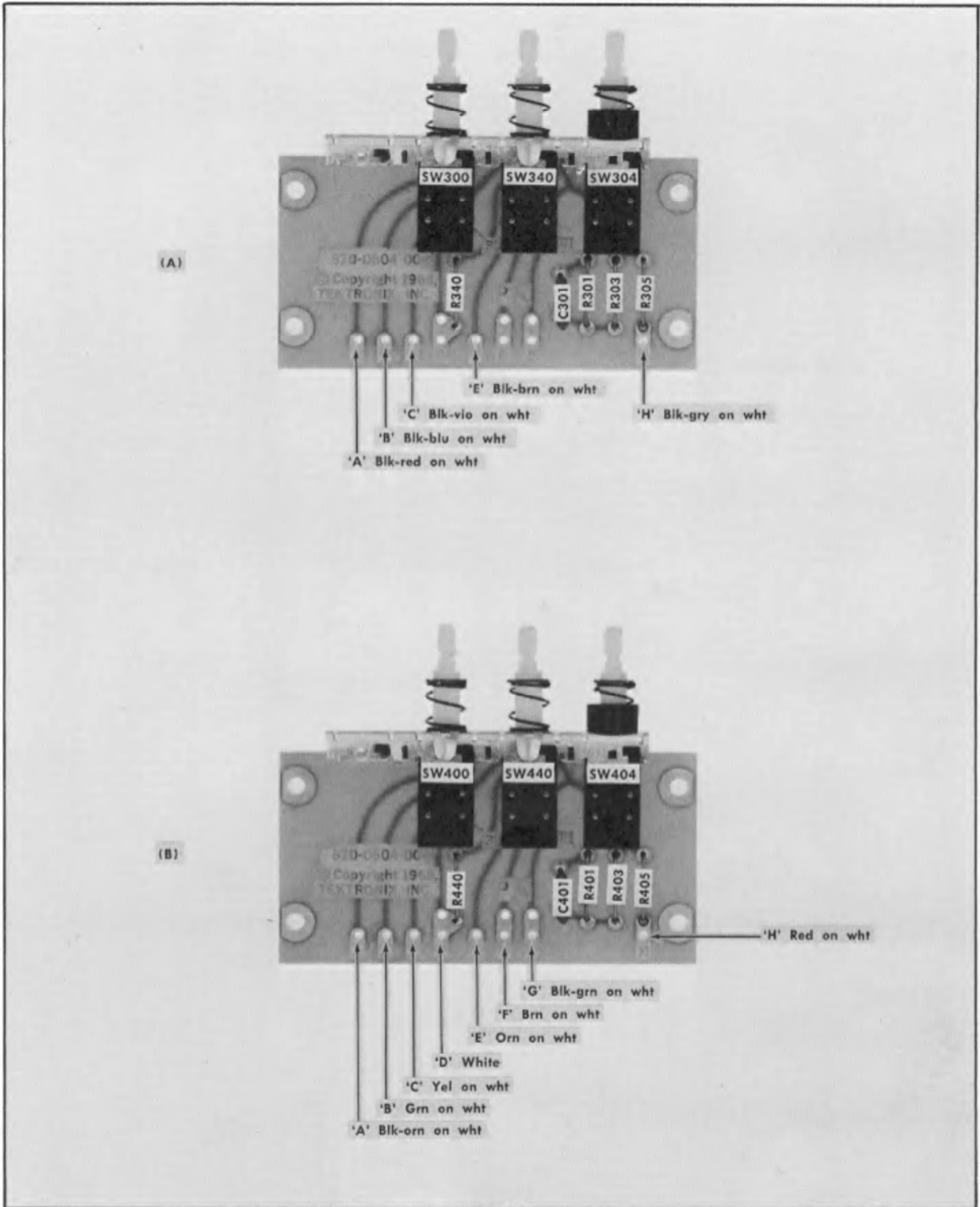

Fig. 4-8. Switch Interface circuit boards; (A) upper and (B) lower.

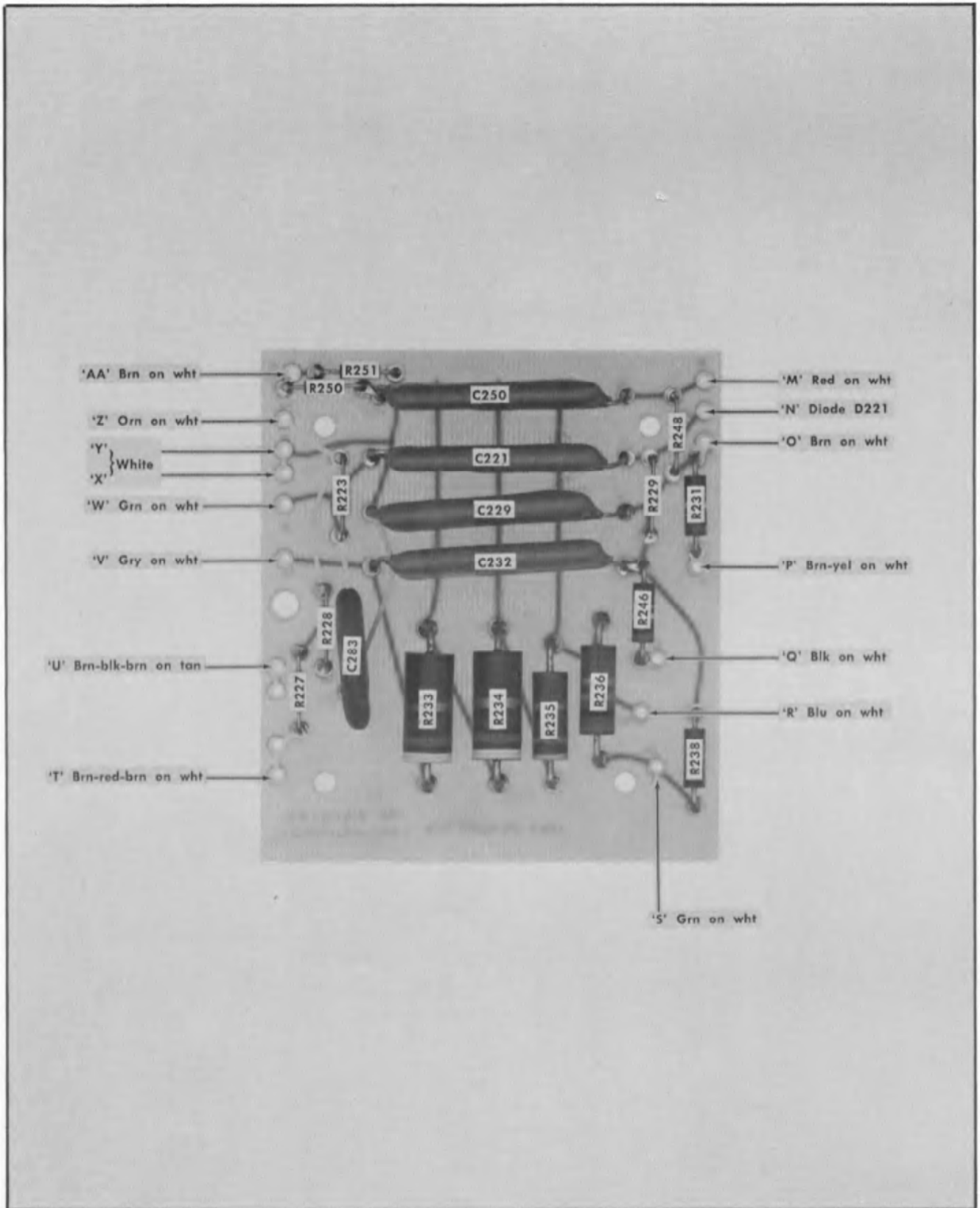

Fig. 4-9. Upper High Voltage circuit board.

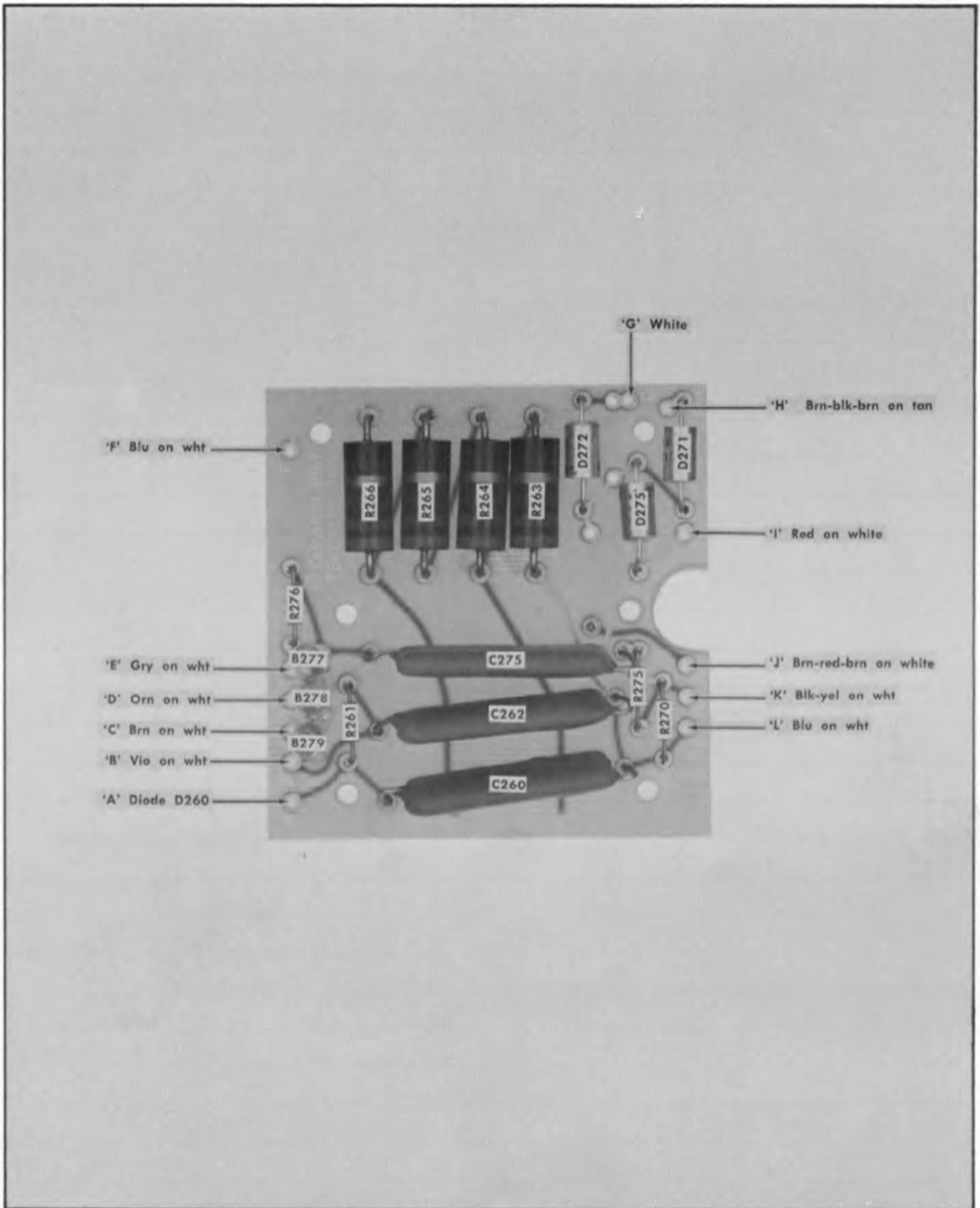

Fig. 4-10. Lower High Voltage circuit board.



# SECTION 5

## PERFORMANCE CHECK / CALIBRATION

Change information, if any, affecting this section will be found at the rear of the manual.

### Introduction

To assure instrument accuracy, check the calibration of the Type R564B every 500 hours of operation, or every six months if used infrequently. Before complete calibration, thoroughly clean and inspect this instrument as outlined in the Maintenance section.

This section provides several features to aid in checking or calibrating this instrument. For example:

**Index.** The Short-Form Procedure lists the step numbers and titles of the Complete Calibration Procedure and gives the page on which each step begins. Therefore, the Short-Form Procedure can be used to locate a step in the complete procedure.

**Calibration Record.** The Short-Form Procedure can be reproduced and used as a permanent record of instrument calibration. Spaces are provided to check off each step as it is completed and to record performance data for this instrument.

**Abridged Calibration Procedure.** The Short-Form Procedure lists the adjustments necessary for each step and the applicable tolerance for correct calibration. The experienced technician who is familiar with the calibration of this instrument can use this procedure to facilitate checking or calibrating it.

**Performance Check.** The Complete Calibration Procedure can be used as a front-panel check of the instrument's performance by doing all portions except the ADJUST— part of a step. When used as a performance check procedure, the instrument is checked to the original performance standards without removing the covers or making internal adjustments. Screwdriver adjustments can be made which are accessible without removing the covers. Some steps are not applicable to a performance checkout procedure. These steps have a note which gives the next applicable step.

**Complete Calibration.** Completion of each step in the Complete Calibration Procedure checks this instrument to the original performance standards and gives the procedure to return each adjustment to its optimum setting. Limits, tolerances and waveforms in this procedure are given as calibration guides and are not instrument specifications. Where possible, instrument performance is checked before an adjustment is made. For best overall instrument performance make each adjustment to the exact setting even if the CHECK— is within the allowable tolerance.

**Partial Calibration.** To check or adjust only part of this instrument, start with the nearest "equipment required" picture preceding the desired portion. To prevent recalibration of other parts of the instrument when performing a partial calibration, readjust only if the tolerance given in the

CHECK— part of the step is not met. If an adjustment is made, any steps listed in the INTERACTION— part of the step should also be checked for correct tolerance.

### TEST EQUIPMENT REQUIRED

#### General

The following test equipment and accessories, or its equivalent, is required for complete calibration of the Type R564B. Specifications given are the minimum necessary for accurate calibration. Therefore, some of the recommended equipment may have specifications which exceed those given. All test equipment is assumed to be correctly calibrated and operating within the given specifications. If equipment is substituted, it must meet or exceed the specifications of the recommended equipment.

For the quickest and most accurate calibration, special Tektronix calibration fixtures are used where necessary. These special calibration fixtures are available from Tektronix, Inc. Order by part number through your local Tektronix Field Office or representative.

1. Vertical amplifier. Dual trace; bandwidth, DC to at least 10 MHz; deflection factor, 0.01 volts/division to 5 volts/division; chopped and alternate modes. Tektronix Type 3A6 Dual-Trace Amplifier recommended.

2. Time-base unit. Normal and delayed sweeps; sweep rates, one millisecond/division to one microsecond/division; 5X magnifier; single-sweep operation. Tektronix Type 3B3 Time-Base Unit recommended.

3. CRT deflection capacitance normalizer. (Normally required only if new cathode-ray tube has been installed or if deflection-plate compensation has been inadvertently misadjusted. Alternate method of adjustment is also given.) Tektronix Calibration Fixture, 067-0500-00, recommended. (For alternate method, Tektronix Type 130 L-C Meter recommended.)

4. Variable autotransformer. Must be capable of supplying at least 204 watts over a voltage range of 90 to 136 volts (180 to 272 volts for 230-volt nominal line). If autotransformer does not have an AC (RMS) voltmeter to indicate output voltage, monitor output with an AC (RMS) voltmeter. For example, General Radio W10MT3W Metered Variac Autotransformer.

5. DC volt-ohmmeter. Minimum sensitivity, 20,000 ohm/volt. For example, Triplett 630.

6. Precision DC voltmeter. Accuracy, within  $\pm 0.05\%$ ; meter resolution, 50 microvolts; range, zero to 3.5 kilovolts. For example, Fluke Model 825A Differential DC Voltmeter (with Fluke Model 80E-5 Voltage Divider to measure the high-voltage supply).

## Performance Check/Calibration—Type R564B

7. Test oscilloscope, with 1X probe. (Optional, for checking power supply ripple.) Bandwidth, DC to 300 kilohertz; minimum deflection factor, five millivolts/division; accuracy, within 3%. Tektronix Type 561B with 2A63 and 2B67 plug-in units, and P6028 Probe recommended.

8. Square-wave generator. Frequency, 100 kilohertz; output amplitude, three volts to ten volts. Tektronix Type 106 Square-Wave Generator recommended.

9. Time-mark generator. Marker outputs, ten microseconds to one millisecond; marker accuracy, within 0.1%. Tektronix Type 184 Time-Mark Generator recommended.

10. Cable. Impedance, 50 ohms; electrical length, five nanoseconds; connectors, GR874. Tektronix Part No. 017-0502-00.

11. Cable, coaxial. Impedance, 50 ohms; length, 42 inches; connectors, BNC. Tektronix Part No. 012-0057-00.

12. Adapter, GR to BNC male. Tektronix Part No. 017-0064-00.

13. Adapter, BNC to banana terminal. For example, Pomona #1269 (Tektronix Part No. 103-0090-00).

14. T connector, BNC. Tektronix Part No. 103-0030-00.

15. Termination. Impedance, 50 ohms; accuracy,  $\pm 3\%$ ; connectors, BNC. Tektronix Part No. 011-0049-00.

16. Current-measuring probe with passive termination. Sensitivity, two milliamperes/millivolt; accuracy, within 3%. Tektronix P6019 Current Probe with 011-0078-00 passive termination recommended.

### SHORT-FORM PROCEDURE

Type R564B, Serial No. \_\_\_\_\_

Calibration Date \_\_\_\_\_

Calibrated By \_\_\_\_\_

- |  |            |   |             |
|--|------------|---|-------------|
| <input type="checkbox"/> 1. Adjust —100-Volt Power Supply<br>—100 volts, $\pm 0.5$ volts   | (Page 5-5) | <input type="checkbox"/> 9. Check External CRT Cathode<br>Intensity (Z-Axis) modulation with 3 volts input.   | Page 5-9    |
| <input type="checkbox"/> 2. Check Low-Voltage Power Supplies   | (Page 5-5) | <input type="checkbox"/> 10. Adjust Trace Alignment<br>Trace parallel to horizontal graticule lines.  | (Page 5-9)  |
| <input type="checkbox"/> 3. Check Low-Voltage Power Supply<br>Regulation and Ripple (Optional Check)                             | (Page 5-5) | <input type="checkbox"/> 11. Adjust CRT Geometry<br>Best overall geometry   | (Page 5-10) |
| <input type="checkbox"/> 4. Adjust High Voltage<br>—3300 volts, $\pm 99$ volts   | (Page 5-6) | <input type="checkbox"/> 12. Check CRT Vertical Deflection Factor<br>18.5 to 20.5 V/cm  | (Page 5-10) |
| <input type="checkbox"/> 5. Check High Voltage Regulation<br>(Optional Check)  | (Page 5-6) | <input type="checkbox"/> 13. Check CRT Vertical Electrical Center<br>Trace within 0.5 major division of graticule horizontal centerline.                          | (Page 5-10) |
| <input type="checkbox"/> 6. Adjust CRT Grid Bias<br>Coarse intensity adjustment.   | (Page 5-6) | <input type="checkbox"/> 14. Check CRT Horizontal Deflection Factor<br>17.5 to 19.25 V/cm   | (Page 5-10) |
| <input type="checkbox"/> 7. Check Alternate Trace<br>Trace alternates at all sweep rates.  | (Page 5-7) | <input type="checkbox"/> 15. Check CRT Horizontal Electrical Center<br>Trace within 0.8 major division of graticule vertical centerline.                          | (Page 5-11) |
| <input type="checkbox"/> 8. Check Dual-Trace Blanking<br>Switching transients (vertical lines) blanked between chopped segments. | (Page 5-8) | <input type="checkbox"/> 16. Check Delaying Sweep Intensification<br>Intensified portion on trace (with delayed sweep time-base unit).                            | (Page 5-11) |
|  |            | <input type="checkbox"/> 17A. Adjust Vertical and Horizontal<br>Deflection- Compensation<br>Optimum square corner (or 14.3 picofarads effective capacitance).     | (Page 5-12) |
|  |            | <input type="checkbox"/> 17B. Alternate Method of Adjusting<br>Deflection-Plate Compensation<br>Optimum square corner (or 14.3 picofarads effective capacitance). | (Page 5-14) |
|  |            | <input type="checkbox"/> 18. Check and Adjust Calibrator Amplitude<br>+40 volts, $\pm 0.6$ volt.  | (Page 5-15) |
|  |            | <input type="checkbox"/> 19. Check and Adjust Calibrator Repetition<br>Rate<br>One kilohertz, $\pm 10$ hertz.   | (Page 5-16) |
|  |            | <input type="checkbox"/> 20. Check Calibrator Duty Factor<br>48% to 52%<br>$\leq 2.5$ microseconds at 40 volts; $\leq 1$ microsecond at all other voltages        | (Page 5-16) |
|  |            | <input type="checkbox"/> 22. Check Current Through Probe Loop<br>Ten milliamperes   | (Page 5-17) |
|  |            | <input type="checkbox"/> 23. Adjust Flood Gun Bias<br>Proper flood-gun coverage of storage target area.   | (Page 5-19) |
|  |            | <input type="checkbox"/> 24. Adjust Collimation<br>Optimum uniform brightness over the storage target area  | (Page 5-10) |
|  |            | <input type="checkbox"/> 25. Check Operating Level Range<br>From $\leq +125$ volts to $\geq +275$ volts.  | (Page 5-21) |
|  |            | <input type="checkbox"/> 26. Adjust Operating Level<br>Optimum stored display   | (Page 5-20) |

## Performance Check/Calibration—Type R564B

- 27. Adjust Non-Store Level (Page 5-22)  
Screen erases promptly and completely when changing from Store to Non-Store Mode.
- 28. Check Writing Speed (Page 5-22)  
Writing speed is  $\geq 25$  cm/ms for T5641-200 storage tube;  $\geq 100$  cm/ms for T5641-201 storage tube.
- 29. Adjust Enhance Amplitude (Page 5-23)  
Maximum writing speed without background deterioration.
- 30. Check Enhanced Writing Speed (Page 5-23)  
Enhanced writing speed is  $\geq 250$  cm/ms for T5641-200 storage tube;  $\geq 500$  cm/ms for T5641-201 storage tube.
- 31. Check Locate Operation (Page 5-23)  
Correct dot displacement
- 32. Check Integrate Function (Page 5-24)

### COMPLETE CALIBRATION PROCEDURE

#### General

The following procedure allows the Type R564B to be calibrated with the least interaction of adjustments and re-connection of equipment. An "equipment required" picture is shown for each group of checks and adjustments to identify the test equipment used. Following this picture is a complete list of front-panel control settings for the Type R564B. Controls which have been changed for the new group of checks and adjustments are printed in bold type. Each step following the test equipment picture continues from the equipment setup and control settings used in the preceding step(s) unless noted otherwise. External controls or adjustments of the Type R564B referred to in this procedure are capitalized (e.g., INTENSITY). Internal adjustment names are initial capitalized only (e.g., High Voltage).

All waveforms shown in this procedure were taken with a Tektronix Oscilloscope Camera System and Projected Graticule. The following procedure uses the equipment listed

under Test Equipment Required. If equipment is substituted, control settings or equipment setup may need to be altered to meet the requirements of the equipment used. Detailed operating instructions for the test equipment are not given in this procedure. If in doubt as to the correct operation of any of the test equipment, refer to the instruction manual for that unit.

#### NOTE

This instrument should be calibrated at an ambient temperature of  $+25^{\circ}\text{C}$ ,  $\pm 5^{\circ}\text{C}$ . The performance of this instrument can be checked at any temperature within the  $0^{\circ}\text{C}$  to  $+50^{\circ}\text{C}$  range. If the ambient temperature is outside the given range, see Section 1 for the applicable tolerances.

#### Preliminary Procedure for Performance Check Only

1. Connect the Type R564B to a power source which meets the voltage and frequency requirements of this instrument.
2. Set the POWER switch to ON. Allow at least 5 minutes warmup before proceeding.
3. Begin the Performance Check with step 7.

#### Preliminary Procedure for Complete Calibration

1. Remove the top and bottom covers from the Type R564B.
2. Set the Line Selector to 115 V and the Range Selector to Medium.
3. Connect the autotransformer to a suitable power source.
4. Connect the Type R564B to the autotransformer output.
5. Set the autotransformer output voltage to 115 volts.
6. Set the POWER switch to ON. Allow at least 5 minutes warmup before proceeding.

#### NOTES

---

---

---

---

---

---

---

---

---

---

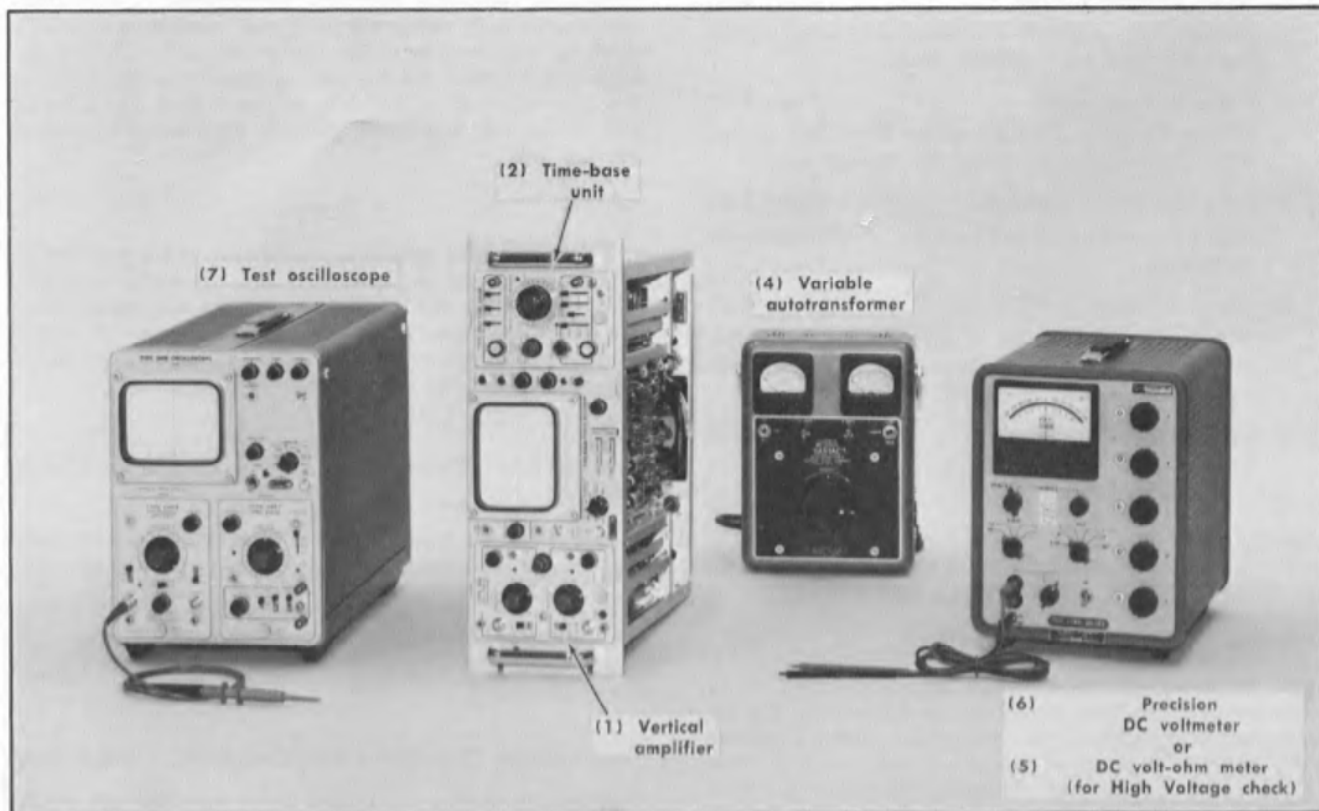

Fig. 5-1. Test equipment required for steps 1 through 6.

**POWER SUPPLIES**

**Control Settings**

**Type R564B**

INTENSITY	Counterclockwise
FOCUS	Midrange
ASTIGMATISM	Midrange
SCALE ILLUM	As desired
CALIBRATOR	OFF
CRT CATHODE SELECTOR (rear panel)	NORM
STORE (both)	Off (out)
ENHANCE (both)	Off (out)

**Vertical Amplifier Unit**

CH 1 Input Coupling	AC
Ch 1 Volts/Div	5
Mode	Ch 1
Position	Centered

**Time-Base Unit**

Mode	Norm
------	------

Time/Div	1 ms
Normal-Single Sweep	Single Sweep
Slope	+
Coupling	Auto
Source	Int
Level	Clockwise

**Test Oscilloscope (Optional—To check ripple)**

Intensity	Nominal brightness
Focus and Astigmatism	Well-defined trace
Time Base	
Mode	Norm
Time/Div	1 ms
Normal-Single Sweep	Norm
Level	0
Slope	+
Coupling	Auto
Source	Int
Vertical Amplifier	
Mode	Ch 1
Volts/Div	0.01
Input Coupling	AC



## 1. Adjust —100-Volt Power Supply ①

For Performance Check only, proceed to step 7.

a. Test equipment required for steps 1 through 6 is shown in Fig. 5-1. The illustrated equipment is keyed to that listed under Test Equipment Required.

b. Connect the precision DC voltmeter between the —100-volt test point and ground (see Fig. 5-2).

c. ADJUST—R23, —100 Volts (Fig. 5-2) for exactly —100 volts.

d. INTERACTION—Operation of all circuits within the Type R564B is affected by the —100-volt supply.

## 2. Check Low-Voltage Power Supplies

a. Connect the precision DC voltmeter between each low-voltage test point and chassis ground. See Fig. 5-2 for test point locations.

b. CHECK—Each supply is within the tolerance listed in Table 5-1.

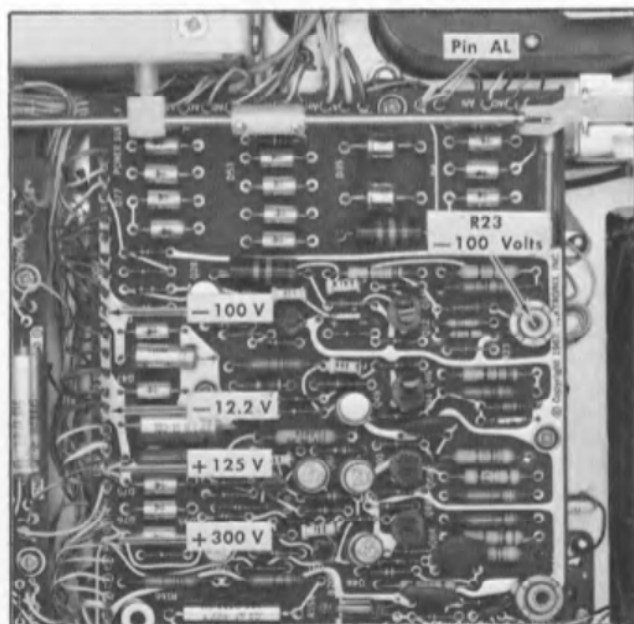

Fig. 5-2. Locations of power supply test points and R23, —100 Volts adjustment.

TABLE 5-1

Supply	Tolerance	Maximum Line Frequency Ripple
+300 V	+295.5 V to +304.5 V	3 mV
+125 V	+123.1 V to +126.9 V	3 mV
-12.2 V	-12.05 V to -12.35 V	2 mV
-100 V	-99.5 V to -100.5 V	2 mV

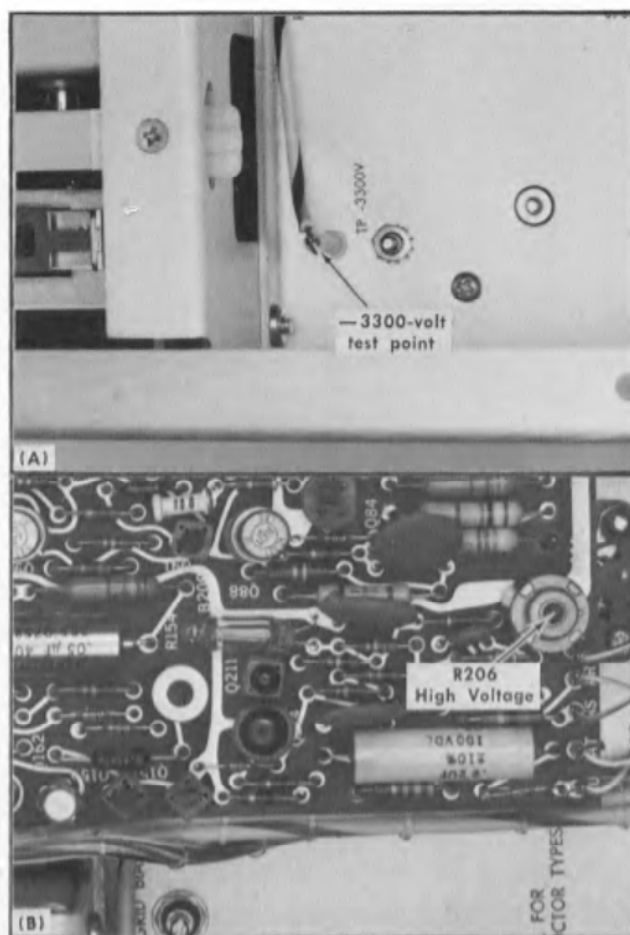

Fig. 5-3. Location of (A) —3300-volt test point, and (B) R206, High Voltage adjustment.

## 3. Check Low-Voltage Power Supply Regulation and Ripple (Optional Check)

a. To check regulation, connect the precision DC voltmeter between each low-voltage supply test point and chassis ground. To check ripple, connect the 1× probe from the test oscilloscope Ch 1 input connector to each test point.

b. Set the autotransformer output to 104 VAC.

c. CHECK—Each supply output and ripple amplitude must be within tolerance listed in Table 5-1.

### NOTE

Power supply voltage and ripple tolerances in this step are guides to correct instrument operation; not instrument performance requirements. Actual values may exceed listed tolerances with no loss in measurement accuracy if the instrument meets the performance requirements in Section 1 as tested in this procedure.

d. Set the autotransformer output to 126 VAC.

e. CHECK—Each supply output and ripple amplitude must be within the tolerance listed in Table 5-1.

## Performance Check/Calibration—Type R564B

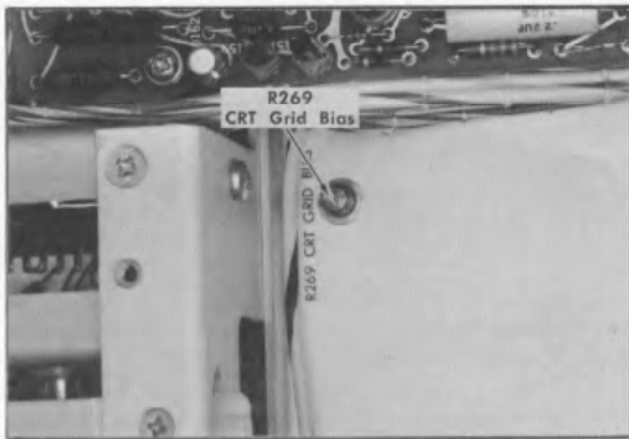

Fig. 5-4. Location of R269, CRT Grid Bias.

f. Return the autotransformer output to 115 VAC and disconnect the precision DC voltmeter and test oscilloscope.

### 4. Adjust High Voltage ①

- a. Connect the DC voltmeter between ground and the -3300-volt test point (Fig. 5-3A).
- b. CHECK—Meter reading must be -3300 volts,  $\pm 99$  V.
- c. ADJUST—R206, High Voltage (Fig. 5-3B), for a meter reading of exactly -3300 volts.

### 5. Check High Voltage Regulation (Optional Check)

- a. With the DC voltmeter connected between ground and the -3300-volt test point, and the High Voltage within the limits stated in step 4B, adjust the autotransformer for an out-

put of 104 VAC and then 126 VAC to check the regulation of the high-voltage supply.

- b. CHECK—Meter reading should not vary more than  $\pm 15$  volts when checking regulation.
- c. Remove the DC voltmeter and return the autotransformer output to 115 VAC.

### 6. Adjust CRT Grid Bias ①

- a. Set the time-base Normal-Single Sweep switch to Normal and rotate the INTENSITY control clockwise until a trace can be seen.
- b. Position the start of the sweep to the left edge of the graticule and adjust the FOCUS control for a well-defined trace.
- c. Rotate the INTENSITY control fully counterclockwise.
- d. Set the time-base Normal-Single Sweep switch to Single Sweep and rotate R269, CRT Grid Bias (Fig. 5-4), counterclockwise.
- e. Press the LOCATE button and hold it in while performing the next step.
- f. ADJUST—R269, CRT Grid Bias, clockwise until a low-intensity spot appears to the left of the sweep start in the locate zone. (It is best to view the CRT trace under low ambient light conditions or by using a viewing hood.)
- g. With the LOCATE button still depressed, rotate the INTENSITY control throughout its range and note that it has no effect on the spot brilliance.
- h. Rotate the INTENSITY control fully counterclockwise and release the LOCATE button.

#### NOTE

The Type R564B may now be connected directly to the power source for the remainder of the procedure, provided the Line Selector and Range Selector switches are set to the proper positions for the source line voltage.

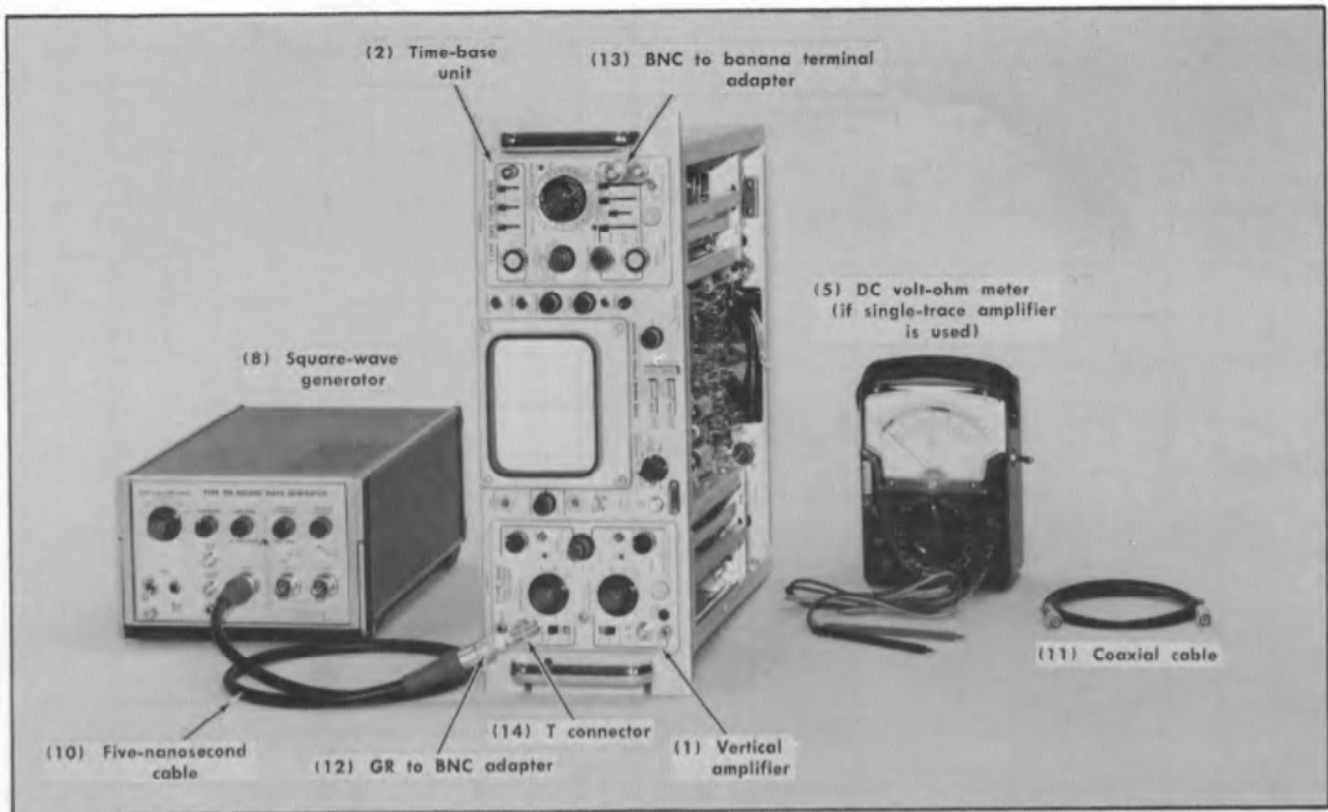

Fig. 5-5. Test equipment required for steps 7 through 16.

### CRT and DEFLECTION CIRCUITS

#### Control Settings

##### Type R564B

INTENSITY	Counterclockwise
FOCUS	Midrange
ASTIGMATISM	Midrange
SCALE ILLUM	As desired
CALIBRATOR	OFF
CRT CATHODE SELECTOR (rear panel)	NORM
STORE (both)	Off (out)
ENHANCE (both)	Off (out)

##### Vertical Amplifier Unit

Input Coupling (Ch 1 & 2)	AC
Volts/Div (Ch 1 & 2)	5
Mode	Alter
Position (Ch 1 & 2)	Centered
Trigger	Composite (pushed in)

##### Time-Base Unit

Mode	Norm
Time/Div	1 ms

##### Normal-Single Sweep

Slope	+
Coupling	Auto
Source	Int
Level	Clockwise

##### Norm

### 7. Check Alternate Trace

a. Test equipment required for steps 7 through 16 is shown in Fig. 5-5. The illustrated equipment is keyed to that listed under Test Equipment Required. If the vertical amplifier unit has only single-trace capabilities, use the substitute procedure following step 7.

b. Set the INTENSITY control for normal display brightness. If necessary, adjust the vertical Position controls so that two traces are displayed on the screen. Adjust FOCUS and ASTIGMATISM for well-defined traces.

c. CHECK—Alternating trace at all sweep rates (all settings of the Time/Div switch).

#### If a single-trace amplifier plug-in unit is used:

a. Turn off the Type R564B and remove both plug-in units temporarily.

b. Make an ohmmeter continuity check between pin 4 of the interconnecting socket in the vertical plug-in compartment and pin 3 of the interconnecting socket in the hori-

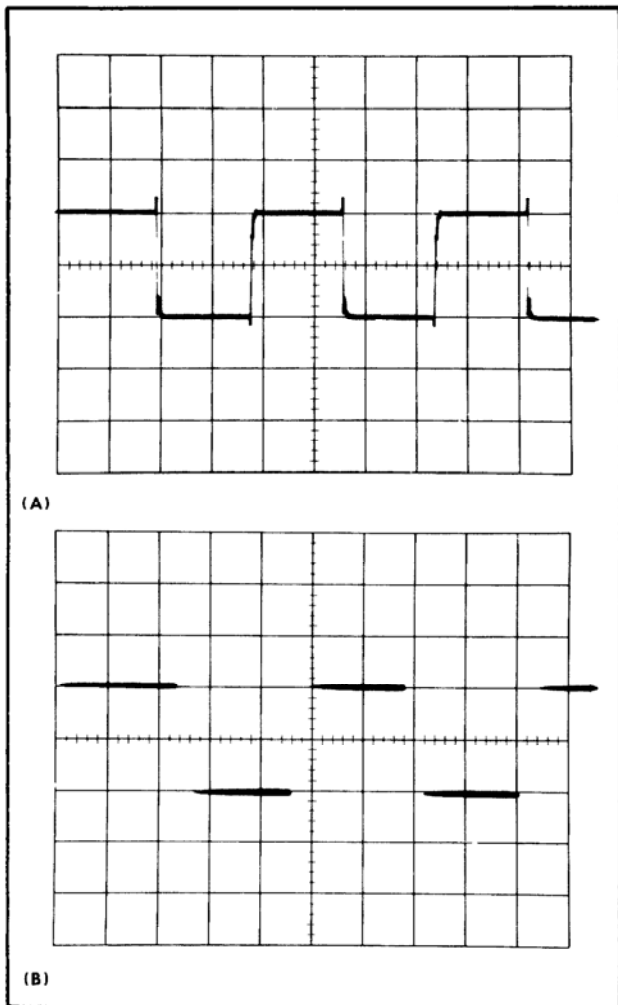

Fig. 5-6. Typical CRT displays showing correct chopped blanking. (A) Chopped transients visible with CRT CATHODE SELECTOR switch set to NORM (Time/Div, 2  $\mu$ s); (B) transients blanked with CRT CATHODE SELECTOR switch set to CHOPPED BLANKING.

zontal plug-in compartment. Also check for infinite resistance between pins 3 and 4 of the vertical plug-in connector. Since the Type R564B interconnects the two plug-in units in the Alternate mode, the continuity check also checks the alternate-trace function.

c. Perform the substitute procedure for single-trace units given in step 8 before re-inserting the plug-in units and applying power to the instrument.

### 8. Check Dual-Trace Blanking

a. Reset the following controls:

Mode (amplifier)	Chop
Time/Div (time-base)	1 $\mu$ s

b. Position the two traces about 2 major divisions apart on the CRT screen and trigger the chopped waveform (see Fig. 5-6A) using the Triggering Level control.

c. Adjust the INTENSITY control so the vertical segments of the chopped waveform are barely visible. Adjust FOCUS and ASTIGMATISM as needed.

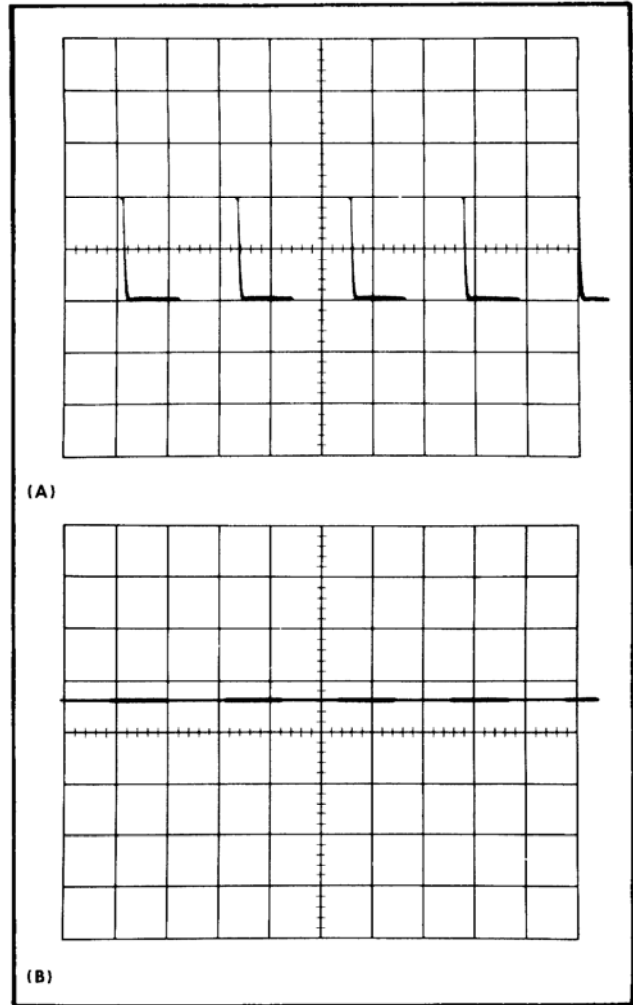

Fig. 5-7. Typical CRT displays when checking intensity modulation; (A) 10-volt signal applied to both vertical amplifier and CRT cathode, (B) 3-volt signal applied only to CRT cathode.

d. Move the CRT CATHODE SELECTOR switch to CHOPPED BLANKING.

e. CHECK—The vertical segments should now be blanked and the horizontal segments should be slightly intensified. (See Fig. 5-6B).

f. Return the CRT CATHODE SELECTOR switch to NORM.

#### If a single-trace amplifier plug-in unit is used.

a. (With power off and amplifier plug-in unit removed) connect the ohmmeter between pin 24 of the interconnecting socket in the vertical plug-in compartment and the wire strap that diagonally connects the inboard terminals of switch SW255 (CRT CATHODE SELECTOR).

b. CHECK—Meter reading is infinity (open circuit) with the CRT CATHODE SELECTOR switch in the NORM and EXT INPUT positions.

c. Set the CRT CATHODE SELECTOR to CHOPPED BLANKING.

d. CHECK—Meter reading is zero ohms (closed circuit). Together with the following external-cathode intensity modu-

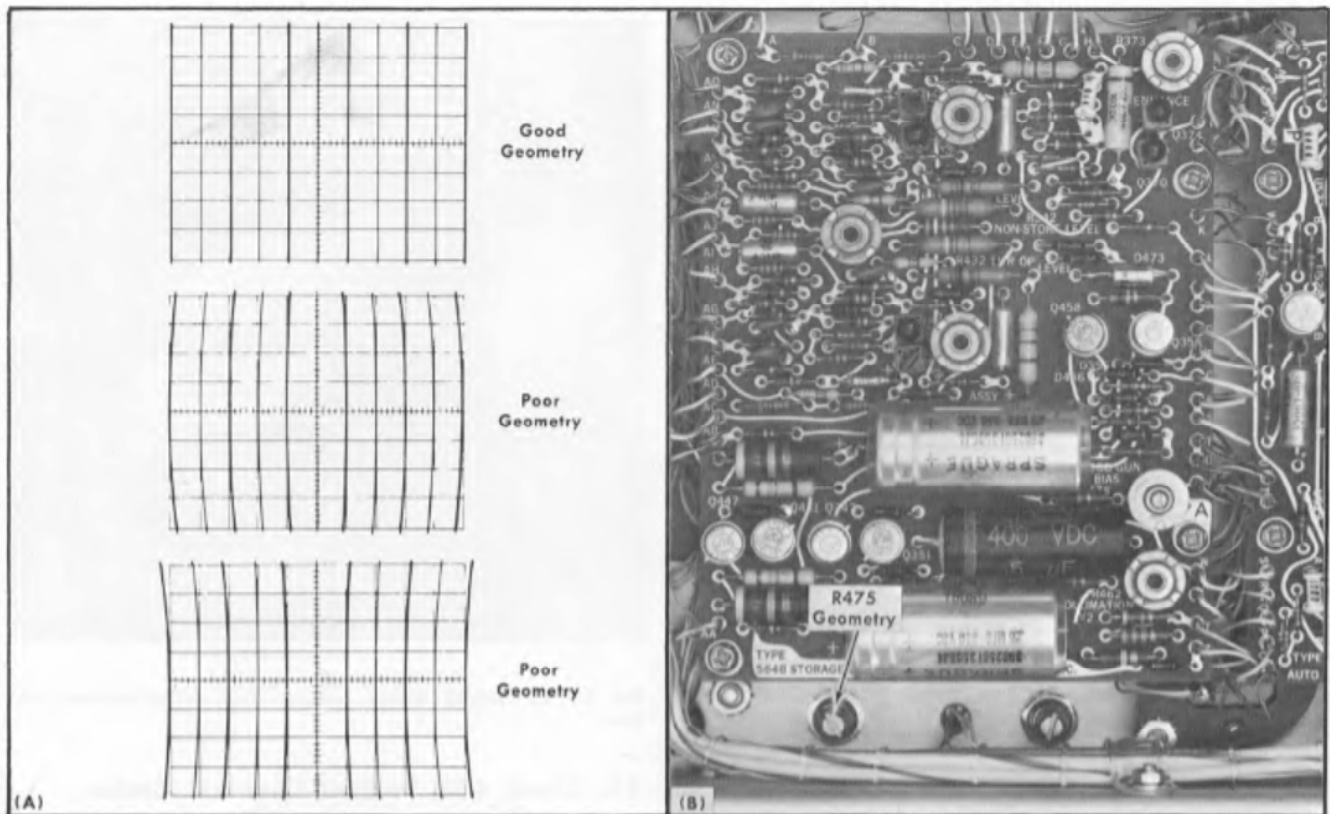

Fig. 5-8. (A) Idealized waveforms showing good geometry with examples of poor geometry; (B) location of R475, Geometry.

lation check, this continuity check tests the chopped blanking function of the Type R564B.

e. Disconnect the ohmmeter and set the CRT CATHODE SELECTOR to NORM.

f. Re-insert the plug-in units into the Type R564B.

g. Set the POWER switch to ON and allow five minutes for the instrument to warm up.

## 9. Check External CRT Cathode

a. Change the following control settings:

Mode (Vertical Amplifier)	Ch 1
Time/Div (Time-Base)	5 $\mu$ s

b. Connect the square-wave generator high amplitude output to the amplifier unit Ch 1 input connector through a 5-nanosecond GR cable and BNC T connector (use a GR to BNC adapter to connect the GR cable to the T connector). Connect a coaxial cable from the T connector to the EXT INPUT connector at the rear of the Type R564B.

c. Set the square-wave generator for a two-division CRT display (10 volts peak to peak) at 100 kilohertz. Adjust the Triggering Level control for a stable display.

d. Decrease the intensity until the waveform is barely visible.

e. Set the CRT CATHODE SELECTOR to EXT INPUT.

f. CHECK—The top portions of the waveform should be blanked completely and the bottom portions should be intensified (see Fig. 5-7A).

g. Set the CRT CATHODE SELECTOR to NORM and the amplifier Volts/Div switch to 1.

h. Adjust the square-wave generator amplitude to produce a three-division CRT display (3 volts peak to peak). Use an attenuator if necessary.

i. Move the signal lead from the amplifier Ch 1 input to the time-base Ext Trig input (use a BNC to banana terminal adapter). Do not remove the signal from the EXT INPUT connector.

j. Set the time-base Source switch to Ext and the CRT CATHODE SELECTOR to EXT INPUT. Trigger the display.

k. CHECK—Intensity modulation should be visible with the 3-volt signal applied (see Fig. 5-7B).

l. Remove the square-wave generator signal.

## 10. Adjust Trace Alignment

a. Change the following control settings:

INTENSITY	Normal display brightness
CRT CATHODE SELECTOR	NORM
Time/Div (time-base)	1 ms
Triggering Level (time-base)	Clockwise
Triggering Source (time-base)	Int

## Performance Check/Calibration—Type R564B

- b. Position the trace to the horizontal centerline.
- c. CHECK—Trace should be parallel to the horizontal graticule lines. If necessary, adjust the TRACE ALIGNMENT adjustment (front panel) to align the trace to the horizontal graticule line.

## 11. Adjust CRT Geometry

- a. Connect the time-mark generator marker output to the amplifier Ch 1 input connector with a coaxial cable.
- b. Set the time-mark generator for 1-millisecond markers.
- c. Trigger the display with the Triggering Level control and position the display baseline to a point below the bottom edge of the graticule.
- d. Set the Volts/Div switch so that the time markers overscan the graticule area.
- e. ADJUST—R475, Geometry (Fig. 5-8B), for minimum bowing of markers at the left and right edges of the graticule.
- f. CHECK—Deviation from straight line should not exceed 0.1 division (see Fig. 5-8A).
- g. Remove the time-mark signal and position the trace to the bottom graticule line.
- h. CHECK—Deviation from straight line should not exceed 0.1 division.
- i. Position the trace to the top graticule line.
- j. CHECK—Deviation from straight line should not exceed 0.1 division.

**For Performance Check only, proceed to step 16.**

## 12. Check CRT Vertical Deflection Factor

**This step is not applicable to Performance Check.**

- a. Connect the DC voltmeter (set to 300-volt scale) between the two vertical deflection-plate neck pins (BLUE and BROWN leads, see Fig. 5-9). Do not short to the CRT shield.
- b. Position the trace to the top graticule line.
- c. Note and record the meter reading.
- d. Remove the meter leads and position the trace to the bottom graticule line.
- e. Reconnect the DC voltmeter between the two vertical deflection-plate neck pins, opposite in polarity to the connection in step a.
- f. Again note and record the meter reading.
- g. Determine the voltage swing over the eight major divisions by adding the meter reading noted in step c to the meter reading noted in step f.
- h. CHECK—Voltage swing over eight major divisions is between 148 and 164 volts. This indicates a vertical deflection factor of 18.5 to 20.5 volts per division.

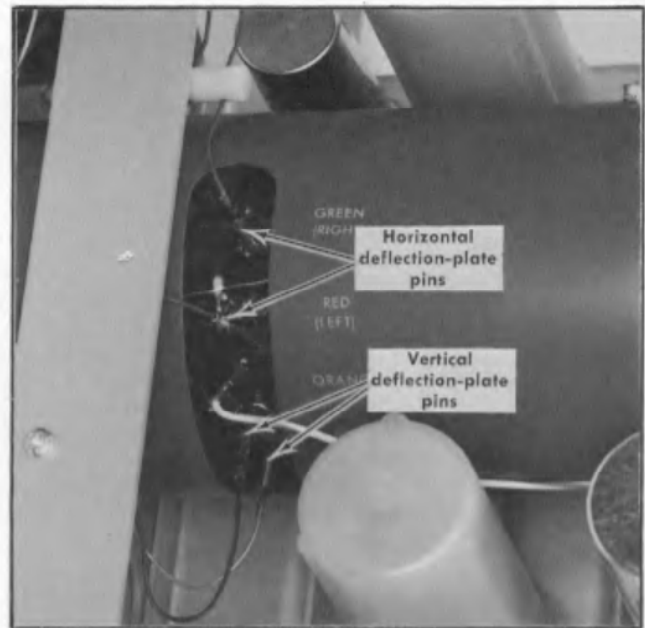

Fig. 5-9. Location of vertical and horizontal deflection-plate neck pins.

## 13. Check CRT Vertical Electrical Center

**This step is not applicable to Performance Check.**

- a. With the DC voltmeter connected between the vertical deflection-plate neck pins, position the trace towards graticule center while observing the meter. Continue to position the trace until the meter reading is zero volts. This is the CRT vertical electrical center.

b. CHECK—Trace must be within 0.5 major division of the graticule centerline.

- c. Disconnect the DC voltmeter.

## 14. Check CRT Horizontal Deflection Factor

**This step is not applicable to Performance Check.**

- a. Rotate the INTENSITY control fully counterclockwise.
- b. Remove the two plug-in units, then insert the time-base plug-in unit into the vertical (left) compartment and the amplifier unit into the horizontal (right) compartment.
- c. Allow about 1/2 minute warmup, then increase the intensity to normal brightness and note the trace is now vertical.
- d. Connect the DC voltmeter (set to 300-volt scale) between the two horizontal deflection-plate neck pins (GREEN and RED leads, see Fig. 5-9).
- e. Position the trace to the left edge of the graticule.
- f. Note and record the meter reading.
- g. Remove the meter leads and position the trace to the right edge of the graticule.



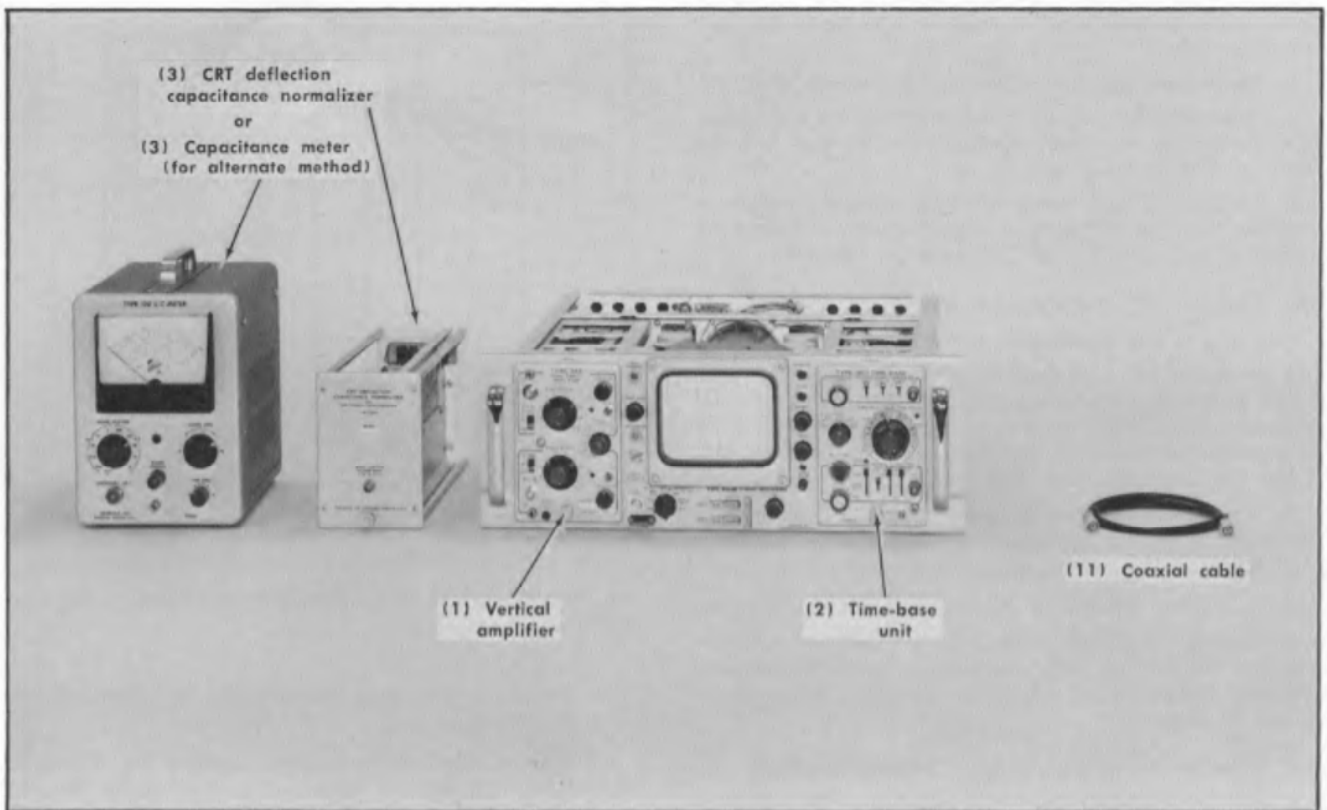

Fig. 5-11. Test equipment required for step 17.

### DEFLECTION-PLATE COMPENSATION

#### Control Settings

##### Type R564B

<b>INTENSITY</b>	Counterclockwise
FOCUS	Well-defined trace
ASTIGMATISM	Well-defined trace
SCALE ILLUM	As desired
CALIBRATOR	OFF
CRT CATHODE SELECTOR (rear panel)	NORM
STORE (both)	Off (out)
ENHANCE (both)	Off (out)

##### Vertical Amplifier Unit

Input Coupling (Ch 1 & 2)	AC
<b>Volts/Div (Ch 1 &amp; 2)</b>	<b>5</b>
Mode	Ch 1
Position	Centered

##### Time-Base Unit

<b>Mode</b>	<b>Norm</b>
<b>Time-Div</b>	<b>0.1 ms</b>
Normal-Single Sweep	Norm

<b>Slope</b>	—
Coupling	Auto
Source	Int
<b>Level</b>	<b>Clockwise</b>

#### 17A. Adjust Vertical and Horizontal Deflection-Plate Compensation

**Omit this step unless the CRT has been replaced.**

a. Test equipment required for step 17 is shown in Fig. 5-11. The illustrated equipment is keyed to that listed under Test Equipment required.

b. Remove the vertical amplifier plug-in unit and insert the CRT Deflection Capacitance Normalizer into the left plug-in compartment.

c. Connect a coaxial cable from the CAL OUT connector to the Capacitance Normalizer input connector.

d. Set the CALIBRATOR switch to 40 V.

#### NOTE

If 40 volts is insufficient to operate the Capacitance Normalizer, clip a wire jumper around R167 to increase the calibrator amplitude for this test.

e. Increase the intensity to normal display brightness and adjust the Triggering Level control for a stable display.



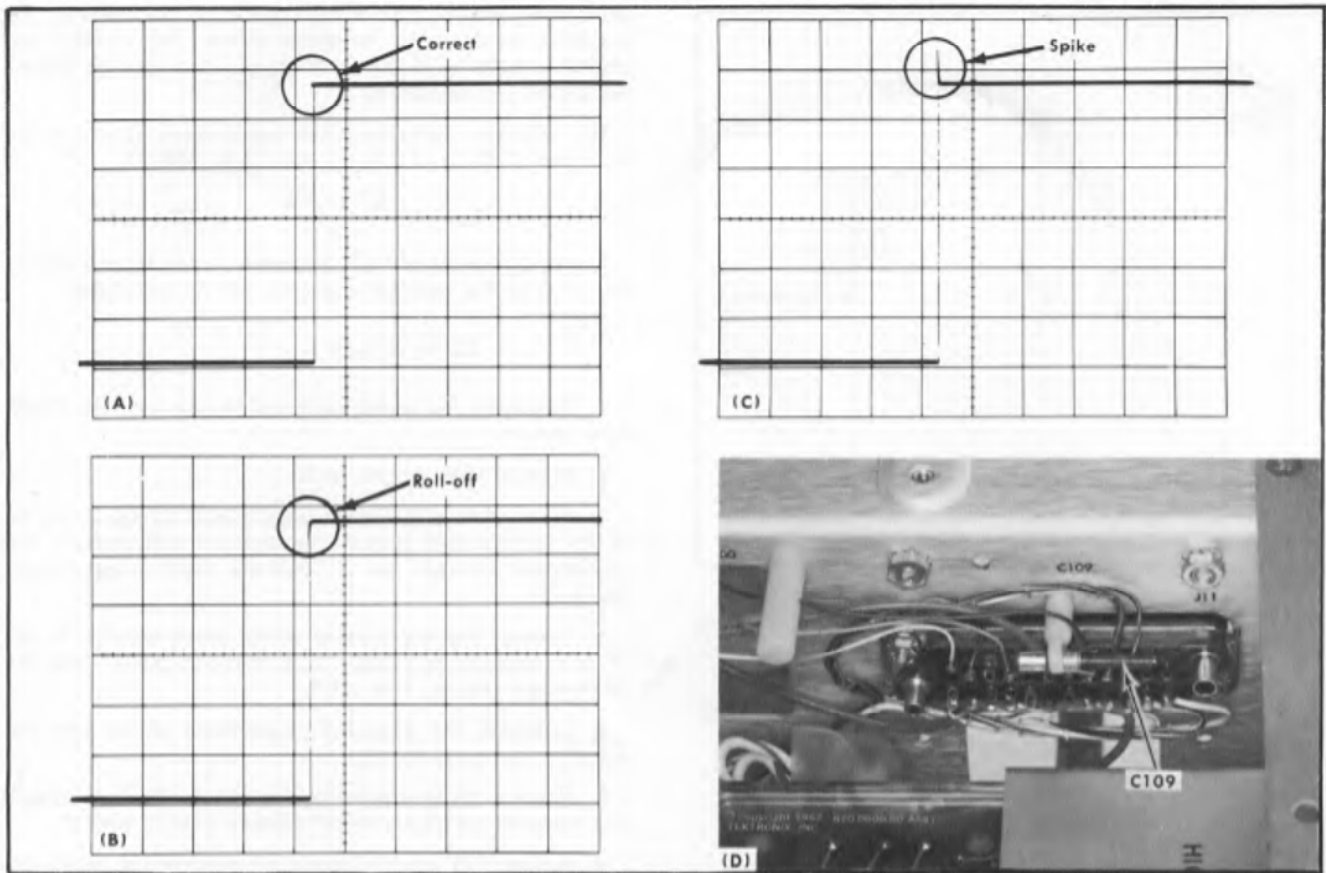

Fig. 5-12. (A) Typical CRT display showing correct vertical compensation adjustment; (B) and (C) incorrect adjustment; (D) location of C109 (left side).

f. Turn the 5× Magnifier on and position the leading edge of the square wave as shown in Fig. 5-12A.

g. ADJUST—C109 (Fig. 5-12D) for optimum square corner.

h. Rotate the INTENSITY control counterclockwise and interchange the Capacitance Normalizer and time-base unit. Readjust the INTENSITY, FOCUS and time-base triggering controls for a stable well-focused display.

i. ADJUST—C102 (Fig. 5-13B) for optimum square corner. See Fig. 5-13A.

j. Turn the 5× Magnifier off and rotate the INTENSITY control counterclockwise.

k. Remove the Capacitance Normalizer. Replace the amplifier unit in the left compartment and the time-base unit in the right compartment.

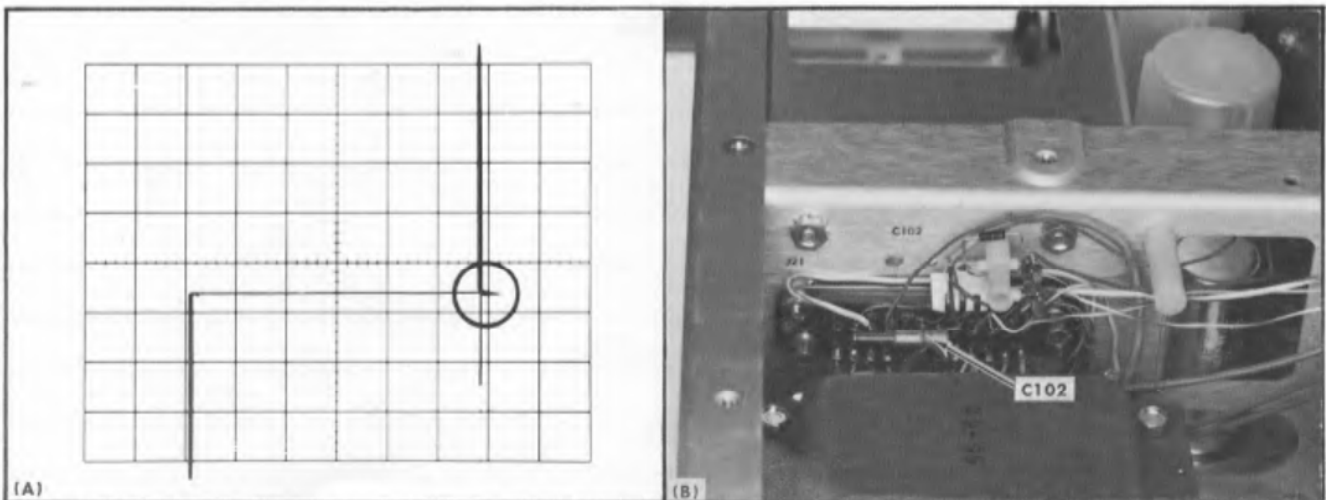

Fig. 5-13. (A) Typical CRT display showing correct adjustment of horizontal compensation; (B) location of C102 (right side).

Performance Check/Calibration—Type R564B

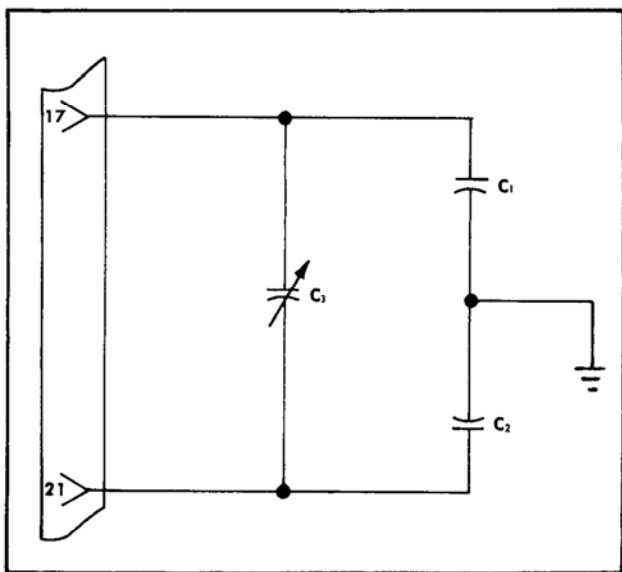

Fig. 5-14. Schematic representation of the effective CRT deflection-plate capacitance.

17B. Alternate Method of Adjusting Deflection-Plate Compensation

NOTE

The following method can be used to adjust the deflection-plate compensation if a Capacitance Normalizer is not available.

The effective deflection-plate capacitance of the CRT is the capacitance seen by the plug-in unit when the deflection plates are driven push-pull. Therefore, it cannot be measured directly with a capacitance meter. However, the individual circuit capacitances which make up the effective deflection-plate capacitance can be measured. These individual circuit capacitances are shown schematically in Fig. 5-14. C1 and C2 represent the capacitance from each

deflection plate to ground. C3 represents the variable capacitance between the deflection plates. The variable capacitor is made up of the circuit capacitance plus the capacitor added for adjustment.

The effective deflection-plate capacitance,  $C_{eff}$ , can be expressed in terms of C1, C2 and C3 as follows:

$$C_{eff} = \frac{C1 + C2}{2} + 2 (C3)$$

Setting  $C_{eff}$  equal to 14.3 picofarads (value set at factory), the value of the variable capacitor can be calculated.

$$C3 = 7.15 \text{ pF} - \frac{C1 + C2}{4}$$

- a. Disconnect the power cord and isolate the Type R564B from ground.
- b. Remove both plug-in units.
- c. Connect the capacitance meter guard voltage to pin 17 of the vertical (left) plug-in compartment and measure the capacitance between pin 17 and the oscilloscope chassis. This is C1.
- d. Connect the capacitance meter guard voltage to pin 17 and measure the capacitance between pin 21 and the oscilloscope chassis. This is C2.
- e. Substitute the measured capacitance values into the equation and solve for C3.
- f. Connect the guard voltage to the oscilloscope chassis and measure the capacitance between pins 17 and 21.
- g. Adjust C109 until the measured capacitance equals the value calculated for C3 in Step e.
- h. Repeat steps c through g for the horizontal (right) plug-in compartment. Adjust C102 for the calculated value of C3.
- i. Remove the capacitance meter.
- j. Replace the plug-in units removed in step b. and re-apply power to the instrument. Allow about five minutes warmup before continuing.

NOTES

---

---

---

---

---

---

---

---

---

---

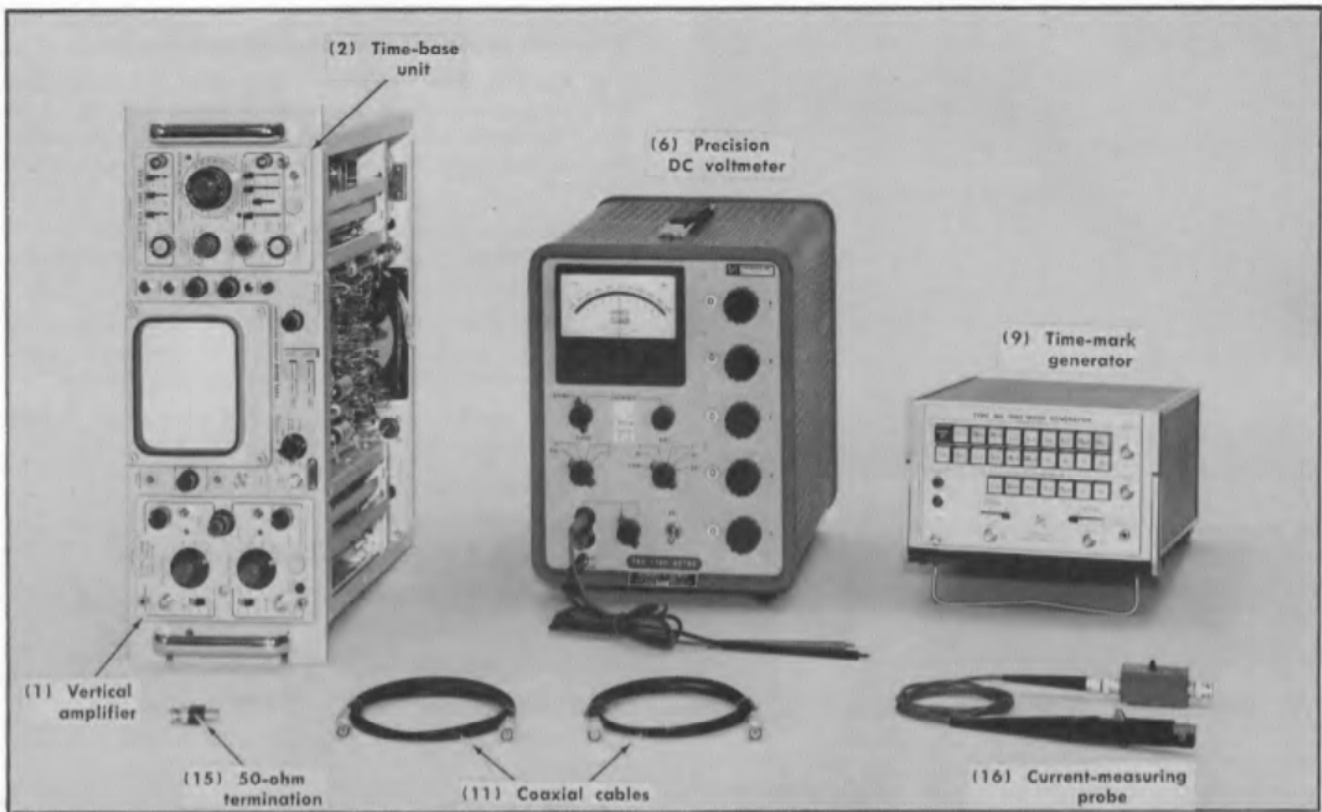

Fig. 5-15. Test equipment required for steps 18 through 22.

**1 kHz CALIBRATOR**

**Control Settings**

Type R564B

<b>INTENSITY</b>	<b>Normal brightness</b>
<b>FOCUS</b>	Well-defined trace
<b>ASTIGMATISM</b>	Well-defined trace
<b>SCALE ILLUM</b>	As desired
<b>CALIBRATOR</b>	<b>10 mA DC (40 V DC)</b>
<b>CRT CATHODE SELECTOR</b> (rear panel)	NORM
<b>STORE (both)</b>	Off (out)
<b>ENHANCE (both)</b>	Off (out)

**Vertical Amplifier**

<b>Input Coupling (Ch 1 &amp; 2)</b>	<b>DC</b>
<b>Volts/Div (Ch 1)</b>	<b>2</b>
<b>Volts/Div (Ch 2)</b>	<b>.5</b>
<b>Mode</b>	<b>Alter</b>
<b>Position (both)</b>	<b>Centered</b>

**Time-Base**

<b>Mode</b>	<b>Norm</b>
-------------	-------------

<b>Time/Div</b>	<b>1 ms</b>
Normal-Single Sweep	Norm
<b>Slope</b>	<b>+</b>
Coupling	Auto
Source	Int
Level	Clockwise

**18. Check and Adjust Calibrator Amplitude**

a. Test equipment required for steps 18 through 22 is shown in Fig. 5-15. The illustrated equipment is keyed to that listed under Test Equipment Required.

b. Connect the differential voltmeter between ground and the CAL OUT connector.

**For Performance Check only:**

**CHECK**—Meter reading is +40 volts,  $\pm 0.6$  V. Proceed to step 19.

c. **ADJUST**—R166, Amplitude (Fig. 5-16) for a meter reading of exactly +40 volts.

d. Remove Q159 (Fig. 5-16) and check the remaining calibrator voltages as listed in Table 5-2. Connect a 50-ohm termination to the CAL OUT connector when checking the 0.2 V, 20 mV and 2 mV positions of the CALIBRATOR switch.

e. Replace Q159 and remove the differential voltmeter.

## Performance Check/Calibration—Type R564B

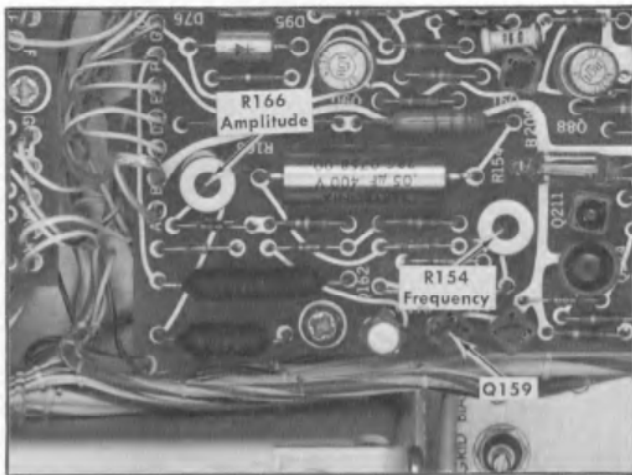

Fig. 5-16. Location of Calibrator controls.

TABLE 5-2

Calibrator	Meter Reading
40 V	+40 V, $\pm 0.6$ V
4 V	+4 V, $\pm 0.06$ V
0.4 V	+0.4 V, $\pm 6$ mV
40 mV	+40 mV $\pm 0.6$ mV
4 mV	+4 mV, $\pm 0.06$ mV
Into 50 $\Omega$ (tolerance within 3%)	
0.2 V	+0.2 V, $\pm 4.5\%$
20 mV	+20 mV, $\pm 4.5\%$
2 mV	+2 mV, $\pm 4.5\%$

### 19. Check and Adjust Calibrator Repetition Rate

- Connect the CAL OUT connector to the Ch 1 input connector with a coaxial cable.
- Set the CALIBRATOR to 4 V.
- Connect the time-mark generator marker output connector to the Ch 2 input connector with a coaxial cable.
- Set the time-mark generator for one-millisecond markers.
- Position the display so that the square-wave calibrator signal is superimposed on the time-mark signal. Adjust the Triggering Level control for a stable display.
- Adjust the time-base Sweep Cal (front panel) for one time marker each major division, and adjust the amplifier Calib control (front panel) for exactly two major divisions of calibrator signal amplitude.

#### For Performance Check only:

**CHECK**—One cycle of calibrator waveform for each marker (see Fig. 5-17). The error in 10 major divisions must be  $\leq 0.5$  minor divisions (the positive transition of the square wave at the right hand edge of the graticule must be no more than 0.5 minor divisions (1 mm) from the positive tran-

sition of the corresponding time marker). **Disconnect the time-mark generator and proceed to step 20.**

- ADJUST—R154, Frequency (Fig. 5-16), for one cycle of calibrator waveform for each marker. See Fig. 5-17. (Since the sweep was calibrated in step f, the display should also be one cycle of calibrator waveform for each major division).
- Position the leading edge of the tenth cycle of calibrator waveform to the center of the graticule and turn the 5 $\times$  Magnifier on.
- Make final adjustment of the Frequency control by aligning the positive-going transition of the square wave with the positive-going transition of the time marker.
- Turn the 5 $\times$  Magnifier off and position the sweep start to the left edge of the graticule.
- Disconnect the time-mark generator.

### 20. Check Calibrator Duty Factor

- Change the following control settings:  
 Mode (amplifier unit) Ch 1  
 Volts/Div (amplifier unit) 1  
 Time/Div (time-base unit) 0.1 ms
- Center the display vertically with the Ch 1 Position control.
- Set the Triggering Level control so the display starts on the rising portion of the waveform.
- Turn the 5 $\times$  Magnifier on.
- Position the 50% point on the falling edge of the calibrator waveform to the center vertical line.
- Set the Triggering Slope to —.
- CHECK**—50% point on the rising edge is now displayed not more than two divisions from the center vertical line (indicates a duty factor of 48% to 52%; see Fig. 5-18).

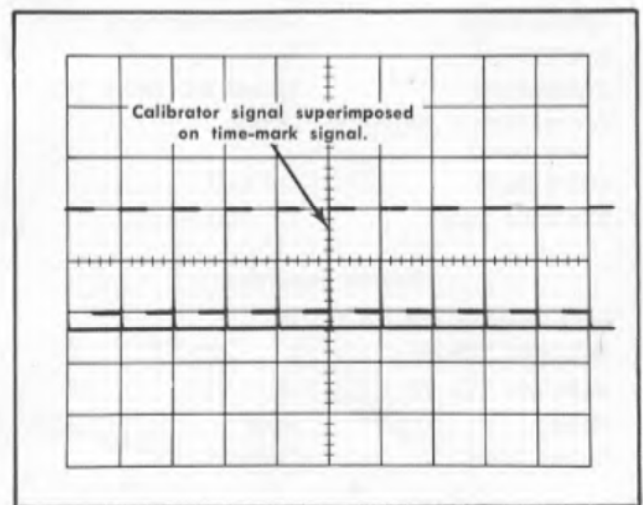

Fig. 5-17. Typical CRT display showing correct calibrator repetition rate.

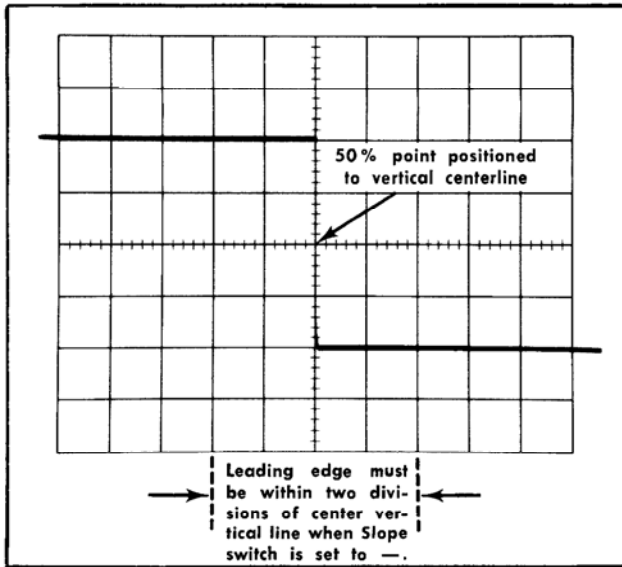

Fig. 5-18. Typical CRT display when checking calibrator duty cycle.

## 21. Check Calibrator Risetime

a. Change the following control settings:

Volts/Div	0.5
5× Mag	Off
Time/Div (Normal Sweep)	0.5 ms
Time/Div (Delayed Sweep)	1 μs
Triggering Slope	+

b. Adjust the amplifier unit Variable Volts/Div control (concentric with Volts/Div switch) for exactly 5 divisions of vertical display.

c. Set the time-base Mode switch to Intensified and adjust the Delay Time dial to brighten the leading edge of the second cycle of display (approximately 2.00).

d. Set the time-base Mode switch to Delayed Sweep.

e. Position the 10% point on the leading edge to a vertical graticule line. It may be necessary to increase the intensity slightly to see the leading edge.

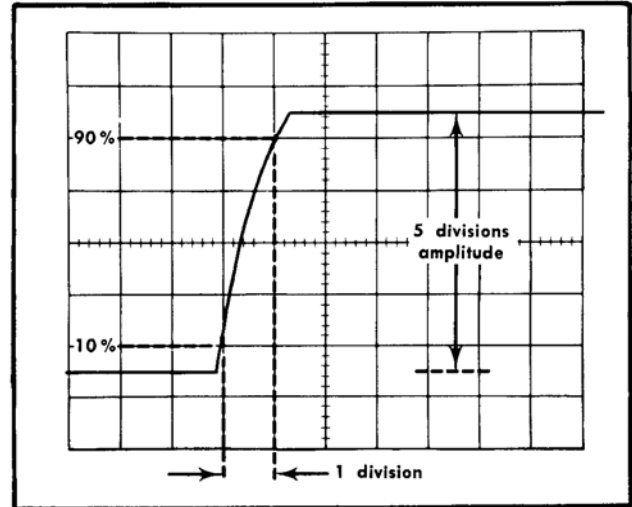

Fig. 5-19. Idealized waveform showing maximum allowable calibrator risetime at sweep rate of 1 μs/division.

f. CHECK—CRT display for one division or less between the 10% and 90% points on the leading edge of the calibrator waveform (one microsecond, or less, risetime; see Fig. 5-19).

g. Set the time-base Mode switch to Norm, amplifier Volts/Div switch to 5 and the Calibrator switch to 40 V.

h. Repeat steps b through e to obtain the leading-edge display of the 40-volt calibrator waveform.

i. CHECK—CRT display for 2.5 divisions or less between the 10% and 90% points on the leading edge of the calibrator waveform (2.5 microseconds, or less, risetime).

j. Disconnect the coaxial cable.

## 22. Check Current Through Probe Loop

a. Change the following control settings:

CALIBRATOR	10 mA
Mode (time-base)	Norm
Volts/Div	0.01 (Calibrated)

## NOTES

---



---



---



---



---



---



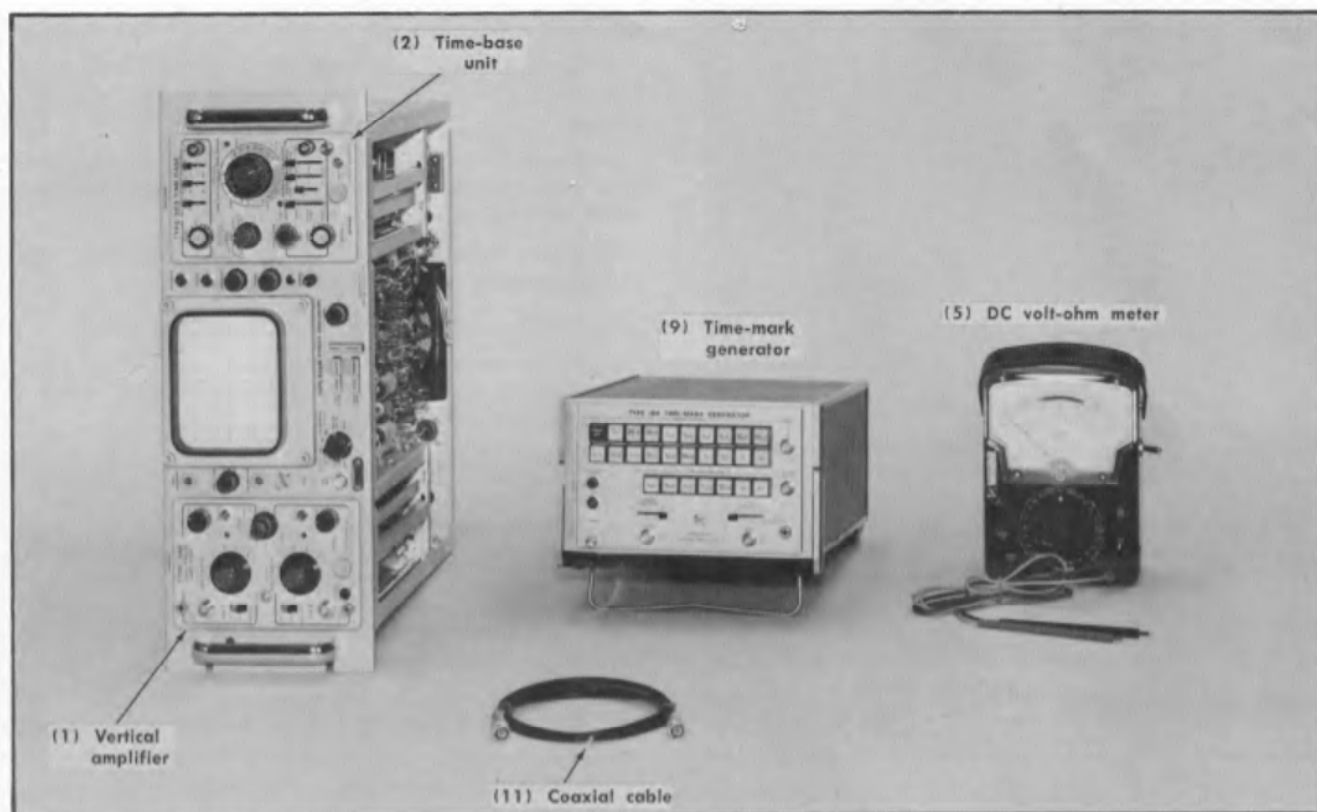

Fig. 5-21. Test equipment required for steps 23 through 32.

## STORAGE SYSTEM

## Control Settings

## Type R564B

INTENSITY	Counterclockwise
FOCUS	Well-defined trace
ASTIGMATISM	Well-defined trace
SCALE ILLUM	As desired
CALIBRATOR	OFF
CRT CATHODE SELECTOR (rear panel)	NORM
STORE (both)	On (pushed in)
ENHANCE (both)	Off (out)

## Vertical Amplifier

Ch 1 Input Coupling	DC
Ch 1 Volts/Div	0.5
Mode	Ch 1
Position	Centered

## Time-Base

Mode	Norm
Time/Div	1 ms
Normal-Single Sweep	Norm
Slope	+

Coupling

Source

Level

Auto

Int

Clockwise

23. Adjust Flood Gun Bias ①

a. Test equipment required for steps 23 through 32 is shown in Fig. 5-21. The illustrated equipment is keyed to that listed under Test Equipment Required.

b. Adjust the INTENSITY control for a sweep of normal display brightness, then write the entire screen by positioning the trace vertically. If the screen fails to write, slightly adjust the INTENSITY control clockwise and repeat the process until the screen is fully written.

c. Rotate the INTENSITY control counterclockwise.

**For Performance Check only:** Check that the entire screen is fully written and without shadows around the corners. **Set both STORE switches to OFF (pushbuttons out) and proceed to step 28.**

d. With the screen fully written, rotate R478, Flood Gun Bias (Fig. 5-22), fully counterclockwise. Note the shadows at the corners of the screen (Fig. 5-23A).

e. Slowly rotate the Flood Gun Bias control clockwise until the shadows just disappear (Fig. 5-23B), then rotate the control another 10° clockwise past this point.

f. Press both ERASE buttons to clear the storage screens.

## Performance Check/Calibration—Type R564B

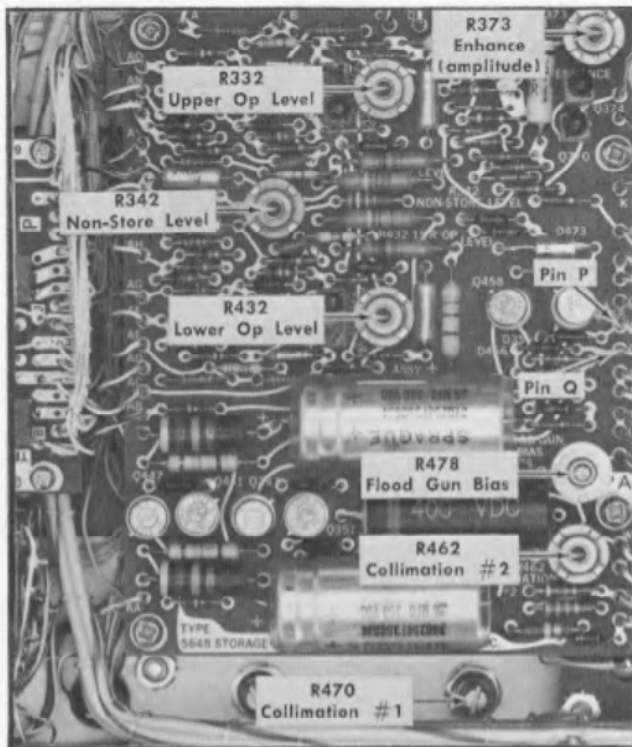

Fig. 5-22. Location of storage controls and test points.

### 24. Adjust Collimation



This step is not applicable to Performance Check.

- Write the entire screen as outlined in step 23b.
- Rotate the INTENSITY control counterclockwise.
- With the screens fully written, rotate R470, Collimation #1 (Fig. 5-22), fully counterclockwise, then clockwise to the point where the screens just begin to brighten.
- Rotate R462, Collimation #2 (Fig. 5-22), fully counterclockwise.
- While continuously pushing both ERASE buttons, note that the screen edges are brightened and pulled in. See Fig. 5-24A.
- Rotate the Collimation #2 control clockwise, and while continuously pushing the ERASE buttons, note the screen edges brighten and exhibit a halo effect. See Fig. 5-24B.
- While continuously pushing the ERASE buttons, adjust the Collimation #2 control clockwise until uniform edge lighting is achieved (Fig. 5-24C).
- INTERACTION—Collimation affects storage capabilities.

### 25. Check Operating Level Range

This step is not applicable to Performance Check.

### UPPER TARGET

a. Connect a DC voltmeter, set to the 300-volt range, between pin P of the Storage board (see Fig. 5-22) and ground.

b. Record the voltmeter reading so that the operating level can be reset to this voltage after the range is checked. Meter reading 160.6 283.7

c. Rotate R332, upper screen Op Level (Fig. 5-22), fully counterclockwise and note the voltmeter reading. 283.7

d. CHECK—Operating level is +125 volts or less.

e. Rotate the upper screen Op Level control fully clockwise, note the voltmeter reading, and rotate the upper screen Op Level control counterclockwise. 96.43

f. CHECK—Operating level noted in step e is +275 volts or more. 285.3

g. Push the upper ERASE button, then adjust the upper screen Op Level control to the voltage recorded in step b.

### LOWER TARGET

h. Connect the DC voltmeter, set to the 300-volt range, between pin Q of the Storage board (see Fig. 5-22) and ground.

i. Record the voltmeter reading so that the operating level can be reset to this voltage after the range is checked. Meter reading 168.2

j. Rotate R432, lower screen Op Level (Fig. 5-22), fully counterclockwise and note the voltmeter reading.

k. CHECK—Operating level is +125 volts or less.

l. Rotate the lower screen Op Level control fully clockwise, note the voltmeter reading, then rotate the lower screen Op Level control counterclockwise.

m. CHECK—Operating level noted in step l is +275 volts or more.

n. Push the lower ERASE button, then adjust the lower screen Op Level control to the voltage recorded in step i.

### 26. Adjust Operating Level



This step is not applicable to Performance Check.

#### NOTE

IF CRT PERFORMANCE HAS BEEN SATISFACTORY, NO ADJUSTMENT OF THE OP LEVEL CONTROLS IS NECESSARY. PROCEED TO STEP 27. Some compromises in the CRT display can be made with slight adjustment of the Op Level controls. When operating level is increased, the brightness and writing speed increase; however, the contrast ratio decreases. When the operating level is decreased, the contrast ratio increases, but the brightness and writing speed decrease.

a. Set both STORE switches to Off (pushbutton out) and increase the intensity to normal display brightness.



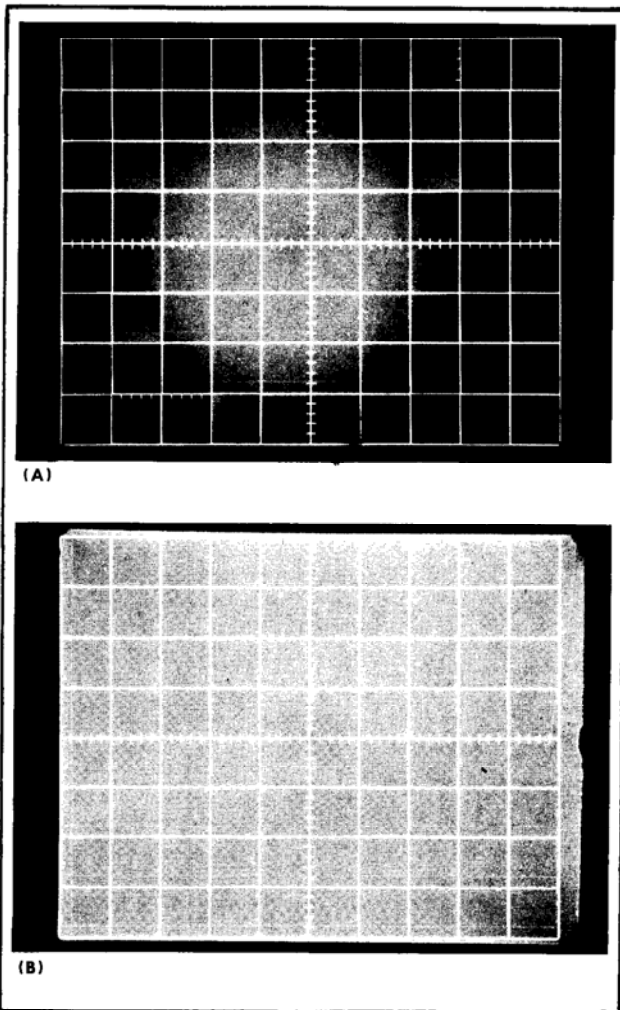

Fig. 5-23. Typical CRT displays showing Flood Gun Bias control (A) adjusted for insufficient screen coverage and (B) adjusted correctly.

b. Adjust the FOCUS and ASTIGMATISM controls for a well-defined trace.

c. Set the time-base Normal-Single Sweep switch to Single Sweep and push in the STORE buttons.

d. When locating the operating point for each target as outlined in the following steps, connect the DC voltmeter to pin P and adjust Op Level R332 for the upper target, and connect the DC voltmeter to pin Q and adjust Op Level R432 for the lower target. These controls and test points are shown in Fig. 5-22.

e. Locate Writing Threshold for both storage screens as follows:

1. Write approximately three lines per centimeter on each target area by pressing the time-base Normal-Single Sweep switch down to the Reset position. After each line is written, change the vertical position before writing the next trace.

2. Carefully check the written lines for breaks or gaps of 0.025 inches or more. If no breaks or gaps are evident

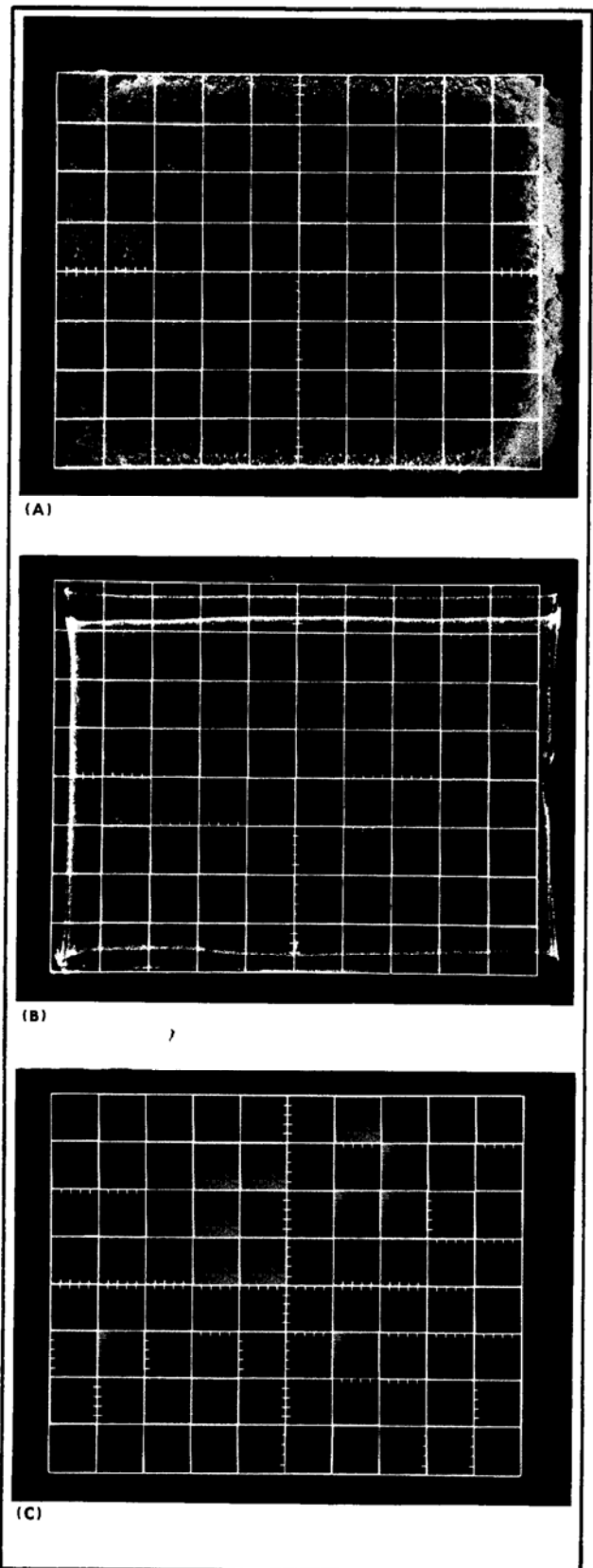

Fig. 5-24. Typical CRT displays showing Collimation #2 adjusted (A) too far clockwise, (B) too far counterclockwise, and (C) for uniform display brightness.

## Performance Check/Calibration—Type R564B

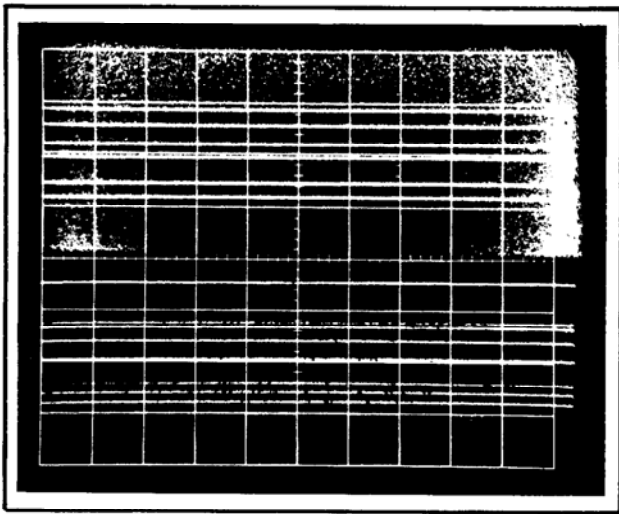

Fig. 5-25. Typical CRT display showing Upper Writing Limit on upper screen and Writing Threshold on lower screen.

after 10 seconds (see Fig. 5-25), note the voltmeter reading, then adjust the Op Level control to reduce the operating level by 5 volts.

3. Erase twice, wait 10 seconds, then write again and check for breaks or gaps.

4. Repeat this procedure of decreasing the operating voltage in 5-volt steps until breaks of approximately 0.025 inches occur. This is the Writing Threshold. Note this voltage and rotate the Op Level control clockwise until the original level noted in step 2 is reached.

### NOTE

Do not change the INTENSITY, FOCUS or ASTIGMATISM control settings.

f. Locate the Upper Writing Limit as follows:

1. Press the ERASE buttons to prepare the target areas for storage.

2. Write approximately three lines per centimeter on the target areas by depressing the Normal-Single Sweep switch down to the Reset position. After each line is written, change the vertical position before writing the next trace.

3. Carefully check the stored lines and background for trace spreading of about 0.025 inches or background fade-up. See Fig. 5-25. If no trace spreading or background fade-up is evident after 10 seconds, adjust the Op Level control to increase the operating level by 5 volts.

4. Erase twice, wait 10 seconds, then write again and check for spreading or fade-up.

5. Repeat this procedure until trace spreading of approximately 0.025 inches, or background fade-up, occurs. This is the Upper Writing Limit. Note this voltage.

g. Adjust the Op Level control for an operating point midway between the Writing Threshold and Upper Writing Limit for each storage target. It is desirable to have both storage targets at the same operating level to minimize the difference in background illumination.

h. Rotate the INTENSITY control counterclockwise and set the Normal-Single Sweep switch to Normal.

i. Disconnect the DC voltmeter.

j. INTERACTION—Collimation is affected if change in operating level is significant.

## 27. Adjust Non-Store Level

This step is not applicable to Performance Check.

a. Set the upper screen STORE switch to Off and erase the lower screen.

b. ADJUST—R342, Non-Store Level (Fig. 5-22), for the best division between the two screens, with no background glow on the upper (non-stored) screen. See Fig. 5-26.

c. Set the lower screen STORE switch to Off.

d. CHECK—The screen must become dark quickly and completely with minimal disturbance of the other screen.

e. Press in both STORE buttons and repeat steps a through d to ensure proper setting of Non-Store Level.

## 28. Check Writing Speed

a. Slowly increase the intensity to the point where the trace begins to defocus rapidly.

b. Set the time-base Normal-Single Sweep switch to Single Sweep and press in both STORE buttons.

c. Alternately store and erase single sweeps of the trace while continuously increasing the sweep rate in small steps. With the Time/Div switch and Variable Time/Div control, adjust the sweep rate for the fastest sweep that will permit the trace to store anywhere on the center 6-cm by 8-cm area of the screens with breaks in the trace not exceeding 1 mm. This is the maximum writing speed of the CRT. (Do not change the settings of the Time/Div or Variable controls until the sweep rate has been measured.)

d. Use the following procedure to determine the sweep speed of the Type R564B at maximum writing speed:

1. Reset only the following controls:

INTENSITY	Counterclockwise
STORE (both)	Off (out)
Normal-Single Sweep (time-base)	Normal

2. Connect the time-mark generator output connector to the amplifier unit Ch 1 input connector with a coaxial cable.

3. Set the time-mark generator for 0.1-millisecond markers.

4. Increase the intensity to normal display brightness and trigger the display.

5. Measure the distance between 0.1-millisecond markers and multiply by ten to determine the writing speed in centimeters per millisecond. For example, if the distance is 3.5 centimeters, the writing speed is 35 cm/ms.

e. CHECK—Writing speed is  $\geq 25$  cm/ms for T5641-200 storage tube;  $\geq 100$  cm/ms for T5641-201 tube.

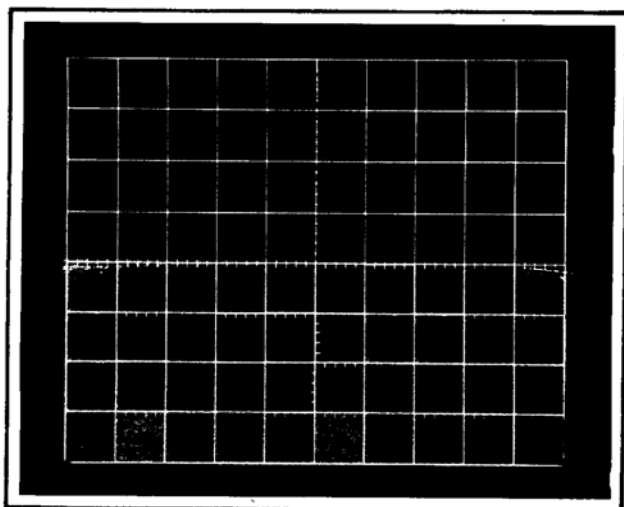

Fig. 5-26. Typical CRT display showing correct adjustment of R342 Non-Store Level.

## NOTE

It may be necessary to repeat this step with a slightly higher trace intensity or higher operating level on the storage-target backplate (see step 26).

- f. Leave the time-mark generator connected.

## 29. Adjust Enhance Amplitude

- a. Change the following control settings:

Input Coupling (amplifier) GND  
Time/Div (time-base) .1 ms calibrated

- b. Slowly increase the intensity to the point where the trace begins to defocus rapidly.

c. Set the Normal-Single Sweep switch to Single Sweep, push in both STORE buttons and both ENHANCE buttons, and rotate the Enhance LEVEL control fully clockwise.

**For Performance Check only, proceed to step 30.**

- d. Rotate R373, Enhance (Fig. 5-22), fully counterclockwise.

e. Alternately store and erase single sweeps of the trace while adjusting R373 clockwise in small steps. Continue adjusting R373 until the enhance pulses cause portions of the screens to start fading positive and the trace just begins to spread into the background. (See Fig. 5-27.)

- f. Erase both screens.

## 30. Check Enhanced Writing Speed

a. Alternately store and erase single sweeps of the trace while continuously increasing the sweep rate in small steps. With the Time/Div switch and Variable Time/Div control, adjust the sweep rate for the fastest sweep that will permit the trace to store anywhere on the center 6-cm by 8-cm area of the screens with breaks in the trace not exceeding 1 mm.

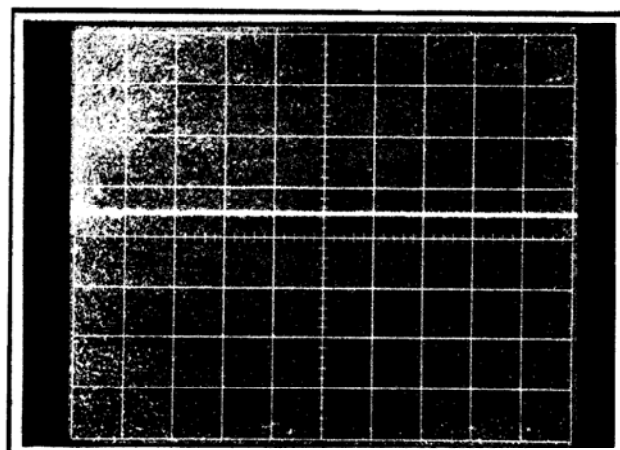

Fig. 5-27. Typical CRT display showing correct adjustment of R373, Enhance (amplitude).

This is the maximum enhanced writing speed of the CRT. (Do not change the settings of the Time/Div or Variable controls until the sweep rate has been measured.)

- b. Use the following procedure to determine the enhanced writing speed.

1. Reset only the following controls:

INTENSITY	Counterclockwise
STORE (both)	Off (out)
Input Coupling (amplifier)	DC
Normal-Single Sweep (time-base)	Normal

2. Set the time-mark generator for 10-microsecond markers.

3. Increase the intensity to normal display brightness and trigger the display.

4. Measure the distance between time markers and multiply by 100 to determine the writing speed in centimeters per millisecond. For example, if the distance is 3.5 centimeters, the writing speed is 350 cm/ms.

c. CHECK—Enhanced writing speed is  $\geq 250$  cm/ms for T5641-200 storage tube;  $\geq 500$  cm/ms for T5641-201 tube.

- d. Disconnect the time-mark generator.

## 31. Check Locate Operation

- a. Change the following control settings:

ENHANCE (both)	Off (out)
Time/Div (time-base)	.1 ms calibrated

- b. Position the trace so that it starts exactly at the left edge of the graticule.

c. Set the Normal-Single Sweep switch to Single Sweep.

d. Press in the LOCATE button.

e. CHECK—A medium-intensity spot should appear off-screen at the left edge of the graticule. It may be neces-



## PARTS LIST ABBREVIATIONS

BHB	binding head brass	int	internal
BHS	binding head steel	lg	length or long
cap.	capacitor	met.	metal
cer	ceramic	mtg hdw	mounting hardware
comp	composition	OD	outside diameter
conn	connector	OHB	oval head brass
CRT	cathode-ray tube	OHS	oval head steel
csk	countersunk	PHB	pan head brass
DE	double end	PHS	pan head steel
dia	diameter	plstc	plastic
div	division	PMC	paper, metal cased
elect.	electrolytic	poly	polystyrene
EMC	electrolytic, metal cased	prec	precision
EMT	electrolytic, metal tubular	PT	paper, tubular
ext	external	PTM	paper or plastic, tubular, molded
F & I	focus and intensity	RHB	round head brass
FHB	flat head brass	RHS	round head steel
FHS	flat head steel	SE	single end
Fil HB	fillister head brass	SN or S/N	serial number
Fil HS	fillister head steel	SW	switch
h	height or high	TC	temperature compensated
hex.	hexagonal	THB	truss head brass
HHB	hex head brass	thk	thick
HHS	hex head steel	THS	truss head steel
HSB	hex socket brass	tub.	tubular
HSS	hex socket steel	var	variable
ID	inside diameter	w	wide or width
incd	incandescent	WW	wire-wound



## PARTS ORDERING INFORMATION

Replacement parts are available from or through your local Tektronix, Inc. Field Office or representative.

Changes to Tektronix instruments are sometimes made to accommodate improved components as they become available, and to give you the benefit of the latest circuit improvements developed in our engineering department. It is therefore important, when ordering parts, to include the following information in your order: Part number, instrument type or number, serial or model number, and modification number if applicable.

If a part you have ordered has been replaced with a new or improved part, your local Tektronix, Inc. Field Office or representative will contact you concerning any change in part number.

## SPECIAL NOTES AND SYMBOLS

- ×000 Part first added at this serial number
- 00× Part removed after this serial number
- \*000-0000-00 Asterisk preceding Tektronix Part Number indicates manufactured by or for Tektronix, Inc., or reworked or checked components.
- Use 000-0000-00 Part number indicated is direct replacement.
-  Screwdriver adjustment.
-  Control, adjustment or connector.

## SECTION 6

# ELECTRICAL PARTS LIST

Values are fixed unless marked Variable.

Ckt. No.	Tektronix Part No.	Serial/Model No. Eff                  Disc	Description			
<b>Bulbs</b>						
B4	150-0047-00		Incandescent	#CN8-398		
B5	150-0047-00		Incandescent	#CN8-398		
B6	150-0047-00		Incandescent	#CN8-398		
B7	150-0045-00		Incandescent	#685		
B209	150-0030-00		Neon, NE 2V.			
B277	150-0030-00		Neon, NE 2V			
B278	150-0030-00		Neon, NE 2V			
B279	150-0030-00		Neon, NE 2V			
<b>Capacitors</b>						
Tolerance $\pm 20\%$ unless otherwise indicated.						
C9	290-0319-00		1300 $\mu\text{F}$	Elect.	150 V	+75%—10%
C11	290-0245-00		1.5 $\mu\text{F}$	Elect.	10 V	10%
C16	281-0523-00		100 pF	Cer	350 V	
C24	281-0546-00		330 pF	Cer	500 V	10%
C31	290-0271-00		9 $\mu\text{F}$	Elect.	125 V	+20%—15%
C36	290-0398-00		10,000 $\mu\text{F}$	Elect.	25 V	+100%—10%
C42	290-0267-00		1 $\mu\text{F}$	Elect.	35 V	
C47	290-0201-00		100 F	Elect.	15 V	
C50	281-0525-00		470 pF	Cer	500 V	
C54	290-0318-00		650 $\mu\text{F}$	Elect.	250 V	+75%—10%
C62	283-0079-00		0.01 $\mu\text{F}$	Cer	250 V	
C65	281-0538-00		240 pF	Cer	500 V	5%
C78	290-0181-00		290 $\mu\text{F}$	Elect.	350 V	
C82	283-0079-00		0.01 $\mu\text{F}$	Cer	250 V	
C88	281-0536-00		1000 pF	Cer	500 V	10%
C97A,B	290-0089-00		3 X 20 $\mu\text{F}$	Elect.	350 V	
C102	281-0027-00		0.7-3 pF, Var	Tub.		
C103	283-0003-00		0.01 $\mu\text{F}$	Cer	150 V	
C109	281-0027-00		0.7-3 pF, Var	Tub.		
C157	*285-0758-00		0.05 $\mu\text{F}$	MT	400 V	2%
C203	283-0000-00		0.001 $\mu\text{F}$	Cer	500 V	
C209	283-0057-00		0.1 $\mu\text{F}$	Cer	200 V	+80%—20%
C215	283-0092-00		0.03 $\mu\text{F}$	Cer	200 V	+80%—20%
C217	285-0572-00		0.1 $\mu\text{F}$	PTM	200 V	
C221	283-0071-00		0.0068 $\mu\text{F}$	Cer	5000 V	

**Electrical Parts List—Type R564B**

**Capacitors (cont)**

Ckt. No.	Tektronix Part No.	Serial/Model No. Eff	No. Disc	Description		
C223	283-0008-00			0.1 $\mu$ F	Cer	500 V
C229	283-0071-00			0.0068 $\mu$ F	Cer	5000 V
C232	283-0071-00			0.0068 $\mu$ F	Cer	5000 V
C250	283-0071-00			0.0068 $\mu$ F	Cer	5000 V
C260	283-0071-00			0.0068 $\mu$ F	Cer	5000 V
C262	283-0071-00			0.0068 $\mu$ F	Cer	5000 V
C275	283-0071-00			0.0068 $\mu$ F	Cer	5000 V
C301	283-0003-00			0.01 $\mu$ F	Cer	150 V
C313	283-0000-00			0.001 $\mu$ F	Cer	500 V
C317	283-0000-00			0.001 $\mu$ F	Cer	500 V
C319	283-0000-00			0.001 $\mu$ F	Cer	500 V
C323	290-0264-00			0.22 $\mu$ F	Elect.	35 V 10%
C330	290-0134-00			22 $\mu$ F	Elect.	15 V
C343	290-0284-00			4.7 $\mu$ F	Elect.	35 V 10%
C355	290-0370-00			25 $\mu$ F	Elect.	350 V +50%—10%
C361	281-0525-00			470 pF	Cer	500 V
C367	285-0629-00	B010100	B039999	0.047 $\mu$ F	PTM	100 V
C367	285-0686-00	B040000		0.068 $\mu$ F	PTM	100 V 10%
C401	283-0003-00			0.01 $\mu$ F	Cer	150 V
C413	283-0000-00			0.001 $\mu$ F	Cer	500 V
C417	283-0000-00			0.001 $\mu$ F	Cer	500 V
C419	283-0000-00			0.001 $\mu$ F	Cer	500 V
C423	290-0264-00			0.22 $\mu$ F	Elect.	35 V 10%
C430	290-0134-00			22 $\mu$ F	Elect.	15 V
C443	290-0284-00			4.7 $\mu$ F	Elect.	35 V 10%
C455	290-0370-00			25 $\mu$ F	Elect.	350 V +50%—10%
C462	285-0537-00			0.5 $\mu$ F	MPT	400 V
C475	283-0002-00	XB090000		0.01 $\mu$ F	Cer	500 V

**Semi-conductor Device, Diodes**

D8A,B,C,D (4)	152-0066-00		Silicon	1N3194
D10	152-0212-00		Zener	1N936 9V, 5%, TC
D19	*152-0185-00		Silicon	Replaceable by 1N4152
D25	152-0333-00		Silicon	High Speed and Conductance
D31	152-0066-00		Silicon	1N3194
D35 A,B(2)	*152-0198-00		Silicon	Replaceable by MR-1032A
D47	152-0066-00		Silicon	1N3194
D53A,B,C,D (4)	152-0066-00		Silicon	1N3194
D62	*152-0185-00		Silicon	Replaceable by 1N4152
D65	*152-0107-00		Silicon	Replaceable by 1N647
D68	*152-0107-00	XB080000	Silicon	Replaceable by 1N647
D70	*152-0107-00	XB080000	Silicon	Replaceable by 1N647
D75	152-0066-00		Silicon	1N3194
D76	152-0066-00		Silicon	1N3194
D77A,B,C,D (4)	152-0066-00		Silicon	1N3194
D80	*152-0185-00		Silicon	Replaceable by 1N4152
D88	*152-0107-00		Silicon	Replaceable by 1N647
D90	*152-0107-00	XB080000	Silicon	Replaceable by 1N647
D91	*152-0107-00	XB080000	Silicon	Replaceable by 1N647



Semi-conductor Device, Diodes (cont)

Ckt. No.	Tektronix Part No.	Serial/Model No. Eff	Disc	Description
D95	152-0066-00			Silicon 1N3194
D103	152-0008-00			Germanium
D105	*152-0061-00			Silicon Tek Spec
D151	*152-0185-00			Silicon Replaceable by 1N4152
D159	*152-0185-00			Silicon Replaceable by 1N4152
D161	*152-0185-00			Silicon Replaceable by 1N4152
D164	*152-0185-00	B010100	B019999	Silicon Replaceable by 1N4152
D164	*152-0107-00	B020000		Silicon Replaceable by 1N647
D168	152-0333-00			Silicon High Speed and Conductance
D204	*152-0107-00			Silicon Replaceable by 1N647
D212	*152-0185-00			Silicon Replaceable by 1N4152
D217	152-0333-00			Silicon High Speed and Conductance
D221	152-0218-00	B010100	B029999	Silicon 10,000 V 20 mA
D221	152-0408-00	B030000		Silicon 10,000 V 5 mA
D260	152-0218-00	B010100	B029999	Silicon 10,000 V 20 mA
D260	152-0408-00	B030000		Silicon 10,000 V 5 mA
D271	152-0066-00			Silicon 1N3194
D272	152-0066-00			Silicon 1N3194
D275	152-0066-00			Silicon 1N3194
D318	*152-0061-00			Silicon Tek Spec
D322	*152-0185-00			Silicon Replaceable by 1N4152
D324	*152-0185-00			Silicon Replaceable by 1N4152
D329	*152-0185-00			Silicon Replaceable by 1N4152
D330	*152-0107-00			Silicon Replaceable by 1N647
D350	*152-0107-00			Silicon Replaceable by 1N647
D352	*152-0107-00			Silicon Replaceable by 1N647
D355	*152-0107-00			Silicon Replaceable by 1N647
D356	152-0247-00			Zener 1N989B 0.4 W, 150 V, 5%
D357	*152-0107-00			Silicon Replaceable by 1N647
D363	*152-0185-00			Silicon Replaceable by 1N4152
D365	*152-0185-00			Silicon Replaceable by 1N4152
D368	*152-0185-00			Silicon Replaceable by 1N4152
D369	*152-0185-00			Silicon Replaceable by 1N4152
D418	*152-0061-00			Silicon Tek Spec
D422	*152-0185-00			Silicon Replaceable by 1N4152
D424	*152-0185-00			Silicon Replaceable by 1N4152
D429	*152-0185-00			Silicon Replaceable by 1N4152
D430	*152-0107-00			Silicon Replaceable by 1N647
D450	*152-0107-00			Silicon Replaceable by 1N647
D452	*152-0107-00			Silicon Replaceable by 1N647
D455	*152-0107-00			Silicon Replaceable by 1N647
D456	152-0247-00			Zener 1N989B 0.4 W, 150 V, 5%
D457	*152-0107-00			Silicon Replaceable by 1N647
D465	*152-0107-00			Silicon Replaceable by 1N647
D473	152-0150-00			Zener 1N3037B 1 W, 51 V, 5%

## Electrical Parts List—Type R564B

### Fuses

Ckt. No.	Tektronix Part No.	Serial/Model No. Eff	No. Disc	Description
F1	159-0026-00		3.2 A.	3AG Slo-Blo
F2	159-0023-00		2 A	3AG Slo-Blo
F9	159-0083-00		150 mA	3AG Fast-Blo

### Connectors

J11	131-0148-00		24 Contact, Female
J21	131-0148-00		24 Contact, Female
J183	131-0274-00		BNC
J255	131-0126-00		BNC
J950	136-0089-00		9 pin

### Inductor

L259	*108-0495-00		CRT Beam Rotator
------	--------------	--	------------------

### Transistors

Q12	151-0190-00		Silicon	2N3904
Q14	151-0190-00		Silicon	2N3904
Q24	151-0190-00		Silicon	2N3904
Q28	*151-0136-00		Silicon	Replaceable by 2N3053
Q30	151-0190-00		Silicon	2N3904
Q32	151-0149-00		Silicon	2N3441
Q38	151-0190-00		Silicon	2N3904
Q44	*151-0192-00		Silicon	Replaceable by MPS-6521
Q46	*151-0192-00		Silicon	Replaceable by MPS-6521
Q49	*151-0136-00		Silicon	Replaceable by 2N3053
Q51	151-0165-00		Germanium	2N3614
Q58	151-0190-00		Silicon	2N3904
Q60	151-0190-00		Silicon	2N3904
Q66	*151-0253-00		Silicon	Replaceable by 2N3439
Q68	*151-0253-00		Silicon	Replaceable by 2N3439
Q70	151-0190-00		Silicon	2N3904
Q74	*151-0256-00		Silicon	Tek Spec
Q84	151-0190-00		Silicon	2N3904
Q86	151-0190-00		Silicon	2N3904
Q88	*151-0253-00		Silicon	Replaceable by 2N3439
Q90	*151-0253-00		Silicon	Replaceable by 2N3439
Q91	151-0190-00		Silicon	2N3904
Q96	*151-0256-00		Silicon	Tek Spec
Q151	*151-0216-00		Silicon	Replaceable by MPS-6523
Q159	*151-0216-00		Silicon	Replaceable by MPS-6523

Transistors (cont)

Ckt. No.	Tektronix Part No.	Serial/Model No. Eff	Disc	Description
Q162	151-0250-00		Silicon	2N5184
Q211	151-1005-00		Silicon	FET
Q214	*151-0228-00		Silicon	Tek Spec
Q219	151-0201-00		Silicon	2N3739
Q325	151-0224-00		Silicon	2N3692
Q328	151-0190-00		Silicon	2N3904
Q347	151-0169-00		Silicon	2N3439
Q351	*151-0150-00		Silicon	Selected from 2N3440
Q358	*151-0150-00		Silicon	Selected from 2N3440
Q370	151-0224-00		Silicon	2N3692
Q374	151-0224-00		Silicon	2N3692
Q425	151-0224-00		Silicon	2N3692
Q428	151-0190-00		Silicon	2N3904
Q447	151-0169-00		Silicon	2N3439
Q451	*151-0150-00		Silicon	Selected from 2N3440
Q458	*151-0150-00		Silicon	Selected from 2N3440

Resistors

Resistors are fixed, composition,  $\pm 10\%$  unless otherwise indicated.

R4	311-0377-00	25 $\Omega$ , Var			
R7	302-0330-00	33 $\Omega$	$\frac{1}{2}$ W		
R8	307-0093-00	1.2 $\Omega$	$\frac{1}{2}$ W		5%
R9	304-0333-00	33 k $\Omega$	1 W		
R10	305-0123-00	12 k $\Omega$	2 W		5%
R11	316-0102-00	1 k $\Omega$	$\frac{1}{4}$ W		
R12	316-0101-00	100 $\Omega$	$\frac{1}{4}$ W		
R13	323-0353-00	46.4 k $\Omega$	$\frac{1}{2}$ W	Prec	1%
R14	323-0394-00	124 k $\Omega$	$\frac{1}{2}$ W	Prec	1%
R16	316-0101-00	100 $\Omega$	$\frac{1}{4}$ W		
R18	321-0268-08	6.04 k $\Omega$	$\frac{1}{8}$ W	Prec	1%
R19	321-0235-00	2.74 k $\Omega$	$\frac{1}{8}$ W	Prec	1%
R20	323-0365-08	61.9 k $\Omega$	$\frac{1}{2}$ W	Prec	1%
R21	321-0445-00	422 k $\Omega$	$\frac{1}{8}$ W	Prec	1%
R23	311-0465-00	100 k $\Omega$ , Var			
R25	315-0154-00	150 k $\Omega$	$\frac{1}{4}$ W		5%
R26	315-0823-00	82 k $\Omega$	$\frac{1}{4}$ W		5%
R29	316-0181-00	180 $\Omega$	$\frac{1}{4}$ W		
R30	315-0132-00	1.3 k $\Omega$	$\frac{1}{4}$ W		5%
R31	315-0204-00	200 k $\Omega$	$\frac{1}{4}$ W		5%
R33	307-0103-00	2.7 $\Omega$	$\frac{1}{4}$ W		5%
R36	304-0103-00	10 k $\Omega$	1 W		
R37	316-0271-00	270 $\Omega$	$\frac{1}{4}$ W		
R38	308-0242-00	0.25 $\Omega$	5 W	WW	5%
R39	316-0101-00	100 $\Omega$	$\frac{1}{4}$ W		

Electrical Parts List—Type R564B

Resistors (cont)

Ckt. No.	Tektronix Part No.	Serial/Model No. Eff	No. Disc	Description		
R40	323-0371-00			71.5 kΩ	1/2 W	Prec 1%
R42	321-0296-03			11.8 kΩ	1/8 W	Prec 1/4%
R43	323-0752-03			85 kΩ	1/2 W	Prec 1/4%
R44	316-0101-00			100 Ω	1/4 W	
R45	323-0333-00			28.7 kΩ	1/2 W	Prec 1%
R47	316-0101-00			100 Ω	1/4 W	
R49	302-0470-00			47 Ω	1/2 W	
R50	302-0100-00			10 Ω	1/2 W	
R52	307-0024-00			2.7 Ω	1/2 W	
R53	307-0024-00			2.7 Ω	1/2 W	
R54	304-0473-00			47 kΩ	1 W	
R56	316-0101-00			100 Ω	1/4 W	
R57	323-0430-00			294 kΩ	1/2 W	Prec 1%
R59	323-0356-00			49.9 kΩ	1/2 W	Prec 1%
R61	316-0101-00			100 Ω	1/4 W	
R62	323-0753-02			121.3 kΩ	1/2 W	Prec 1/2%
R63	323-0384-02			97.6 kΩ	1/2 W	Prec 1/2%
R65	316-0151-00			150 Ω	1/4 W	
R66	302-0224-00			220 kΩ	1/2 W	
R69	315-0511-00			510 Ω	1/4 W	5%
R70	315-0104-00			100 kΩ	1/4 W	5%
R72	316-0181-00			180 Ω	1/4 W	
R75	307-0103-00			2.7 Ω	1/4 W	5%
R77	307-0024-00			2.7 Ω	1/2 W	
R78	304-0104-00			100 kΩ	1 W	
R80	323-1429-02			291 kΩ	1/2 W	Prec 1/2%
R81	323-0384-02			97.6 kΩ	1/2 W	Prec 1/2%
R83	316-0101-00			100 Ω	1/4 W	
R85	323-0356-00			49.9 kΩ	1/2 W	Prec 1%
R86	323-0430-00			294 kΩ	1/2 W	Prec 1%
R87	316-0101-00			100 Ω	1/4 W	
R88	316-0471-00			470 Ω	1/4 W	
R89	302-0224-00			220 kΩ	1/2 W	
R90	315-0162-00			1.6 kΩ	1/4 W	5%
R91	315-0564-00			560 kΩ	1/4 W	5%
R92	315-0122-00			1.2 kΩ	1/4 W	5%
R94	307-0103-00			2.7 Ω	1/4 W	5%
R95	316-0181-00			180 Ω	1/4 W	
R101	308-0124-00	B010100	B059999	6 kΩ	10 W	WW 5%
R101	308-0021-00	B060000		47 kΩ	1/4 W	
R103	316-0473-00			4.5 kΩ	10 W	WW 5%
R105	316-0105-00			1 MΩ	1/4 W	
R106	316-0105-00			1 MΩ	1/4 W	
R150	323-0403-00			154 kΩ	1/2 W	Prec 1%
R153	308-0501-00			5.45 kΩ	1.5 W	WW 1%
R154	311-0826-00			750 Ω, Var		

## Resistors (cont)

Ckt. No.	Tektronix Part No.	Serial/Model No. Eff	No. Disc	Description		
R156	315-0624-00		620 k $\Omega$	$\frac{1}{4}$ W		5%
R158	323-0404-00		158 k $\Omega$	$\frac{1}{2}$ W	Prec	1%
R160	315-0224-00		220 k $\Omega$	$\frac{1}{4}$ W		5%
R164	308-0515-00		14.5 k $\Omega$	5 W	WW	1%
R166	311-0732-00		1 k $\Omega$ , Var			
R167	308-0492-00		8.15 k $\Omega$	3 W	WW	1%
R170	323-0741-03		3.6 k $\Omega$	$\frac{1}{2}$ W	Prec	$\frac{1}{4}$ %
R171	321-0773-03		400 $\Omega$	$\frac{1}{8}$ W	Prec	$\frac{1}{4}$ %
R173	321-0772-02		63 $\Omega$	$\frac{1}{8}$ W	Prec	$\frac{1}{2}$ %
R175	321-0774-03		4.5 k $\Omega$	$\frac{1}{8}$ W	Prec	$\frac{1}{4}$ %
R176	321-0775-03		45 k $\Omega$	$\frac{1}{8}$ W	Prec	$\frac{1}{4}$ %
R178	308-0488-00		5 $\Omega$	2.5 W	WW	2%
R179	308-0499-00		0.5 $\Omega$	2.5 W	WW	
R181	321-0771-03		50 $\Omega$	$\frac{1}{8}$ W	Prec	$\frac{1}{4}$ %
R183	*308-0090-00		0.25 $\Omega$	1 W	WW	
R200	315-0103-00		10 k $\Omega$	$\frac{1}{4}$ W		5%
R201	322-0464-00		665 k $\Omega$	$\frac{1}{4}$ W	Prec	1%
R203	315-0474-00		470 k $\Omega$	$\frac{1}{4}$ W		5%
R204	316-0336-00		33 M $\Omega$	$\frac{1}{4}$ W		
R205	316-0472-00		4.7 k $\Omega$	$\frac{1}{4}$ W		
R206	311-0465-00		10 k $\Omega$ , Var			
R208	316-0225-00		2.2 M $\Omega$	$\frac{1}{4}$ W		
R210	315-0104-00		100 k $\Omega$	$\frac{1}{4}$ W		5%
R211	315-0154-00		150 k $\Omega$	$\frac{1}{4}$ W		5%
R213	316-0102-00		1 k $\Omega$	$\frac{1}{4}$ W		
R215	316-0333-00		33 k $\Omega$	$\frac{1}{4}$ W		
R216	302-0333-00		33 k $\Omega$	$\frac{1}{2}$ W		
R217	316-0105-00		1 M $\Omega$	$\frac{1}{4}$ W		
R218	301-0510-00		51 $\Omega$	$\frac{1}{2}$ W		5%
R223	316-0102-00		1 k $\Omega$	$\frac{1}{4}$ W		
R225	311-0018-00		20 k $\Omega$ , Var			
R226	305-0563-00		56 k $\Omega$	2 W		5%
R227	315-0334-00		330 k $\Omega$	$\frac{1}{4}$ W		5%
R228	315-0134-00		130 k $\Omega$	$\frac{1}{4}$ W		5%
R229	316-0223-00		22 k $\Omega$	$\frac{1}{4}$ W		
R231	302-0104-00		100 k $\Omega$	$\frac{1}{2}$ W		
R233	305-0475-00		4.7 M $\Omega$	2 W		5%
R234	305-0475-00		4.7 M $\Omega$	2 W		5%
R235	303-0365-00		3.6 M $\Omega$	1 W		5%
R236	304-0106-00		10 M $\Omega$	1 W		
R237	311-0254-00		5 M $\Omega$ , Var			
R238	301-0225-00		2.2 M $\Omega$	$\frac{1}{2}$ W		5%
R240	316-0472-00		4.7 k $\Omega$	$\frac{1}{4}$ W		
R242	316-0472-00		4.7 k $\Omega$	$\frac{1}{4}$ W		
R243	316-0472-00		4.7 k $\Omega$	$\frac{1}{4}$ W		

Electrical Parts List—Type R564B

Resistors (cont)

Ckt. No.	Tektronix Part No.	Serial/Model No. Eff	No. Disc	Description		
R244	316-0564-00		560 kΩ	1/4 W		
R246	302-0104-00		100 kΩ	1/2 W		
R248	316-0273-00		27 kΩ	1/4 W		
R250	316-0471-00		470 Ω	1/4 W		
R251	316-0105-00		1 MΩ	1/4 W		
R257	311-0206-00		250 kΩ, Var			
R259	311-0007-00		2 X 1 kΩ, Var			
R261	316-0104-00		100 kΩ	1/4 W		
R263	305-0825-00		8.2 MΩ	2 W		5%
R264	305-0825-00		8.2 MΩ	2 W		5%
R265	305-0825-00		8.2 MΩ	2 W		5%
R266	305-0825-00		8.2 MΩ	2 W		5%
R269	311-0469-00		1 MΩ, Var			
R270	316-0223-00		22 kΩ	1/4 W		
R273	302-0104-00		100 kΩ	1/2 W		
R274	315-0242-00		2.5 kΩ	1/4 W		5%
R275	316-0471-00		470 Ω	1/4 W		
R276	316-0105-00		1 MΩ	1/4 W		
R301	316-0106-00		10 MΩ	1/4 W		
R303	316-0102-00		1 kΩ	1/4 W		
R305	316-0103-00		10 kΩ	1/4 W		
R310	316-0103-00		10 kΩ	1/4 W		
R312	316-0106-00		10 MΩ	1/4 W		
R313	316-0105-00		1 MΩ	1/4 W		
R315	316-0106-00		10 MΩ	1/4 W		
R316	316-0105-00		1 MΩ	1/4 W		
R317	316-0103-00		10 kΩ	1/4 W		
R318	316-0105-00		1 MΩ	1/4 W		
R319	316-0103-00		10 kΩ	1/4 W		
R321	315-0184-00		180 kΩ	1/4 W		5%
R322	315-0563-00		56 kΩ	1/4 W		5%
R324	316-0104-00		100 kΩ	1/4 W		
R326	315-0133-00		13 kΩ	1/4 W		5%
R328	323-0353-00		46.4 kΩ	1/2 W	Prec	1%
R329	316-0221-00		220 Ω	1/4 W		
R331	323-0346-00		39.2 kΩ	1/2 W	Prec	1%
R332	311-0510-00		10 kΩ, Var			
R334	323-0402-00		150 kΩ	1/2 W	Prec	1%
R335	321-0356-00		49.9 kΩ	1/8 W	Prec	1%
R337	321-0307-00		15.4 kΩ	1/8 W	Prec	1%
R338	321-0333-00		28.7 kΩ	1/8 W	Prec	1%
R339	321-0349-00		42.2 kΩ	1/8 W	Prec	1%
R340	316-0473-00		47 kΩ	1/4 W		
R341	315-0333-00		33 kΩ	1/4 W		5%
R342	311-0463-00		5 kΩ, Var			

## Resistors (cont)

Ckt. No.	Tektronix Part No.	Serial/Model No. Eff	No. Disc	Description		
R343	315-0333-00			33 k $\Omega$	1/4 W	5%
R344	301-0393-00			39 k $\Omega$	1/4 W	5%
R347	305-0473-00			47 k $\Omega$	2 W	5%
R353	323-0430-00			294 k $\Omega$	1/2 W	1%
R354	315-0824-00			820 k $\Omega$	1/4 W	5%
R356	316-0103-00			10 k $\Omega$	1/4 W	
R357	316-0222-00			2.2 k $\Omega$	1/4 W	
R359	302-0823-00			82 k $\Omega$	1/2 W	
R361	316-0103-00			10 k $\Omega$	1/4 W	
R363	316-0104-00			100 k $\Omega$	1/4 W	
R364	316-0472-00			4.7 k $\Omega$	1/4 W	
R366	311-0641-00			200 k $\Omega$ , Var		
R367	315-0223-00	B010100	B039999	22 k $\Omega$	1/4 W	5%
R367	315-0203-00	B040000		20 k $\Omega$	1/4 W	5%
R368	315-0273-00			27 k $\Omega$	1/4 W	5%
R370	316-0103-00			10 k $\Omega$	1/4 W	
R372	316-0472-00			4.7 k $\Omega$	1/4 W	
R373	311-0510-00			10 k $\Omega$ , Var		
R401	316-0106-00			10 M $\Omega$	1/4 W	
R403	316-0102-00			1 k $\Omega$	1/4 W	
R405	316-0103-00			10 k $\Omega$	1/4 W	
R410	316-0103-00			10 k $\Omega$	1/4 W	
R412	316-0105-00			10 M $\Omega$	1/4 W	
R413	316-0105-00			1 M $\Omega$	1/4 W	
R415	316-0106-00			10 M $\Omega$	1/4 W	
R416	316-0105-00			1 M $\Omega$	1/4 W	
R417	316-0103-00			10 k $\Omega$	1/4 W	
R418	316-0105-00			1 M $\Omega$	1/4 W	
R419	316-0103-00			10 k $\Omega$	1/4 W	
R421	315-0184-00			180 k $\Omega$	1/4 W	5%
R422	315-0563-00			56 k $\Omega$	1/4 W	5%
R424	316-0104-00			100 k $\Omega$	1/4 W	
R426	315-0133-00			13 k $\Omega$	1/4 W	5%
R428	323-0353-00			46.4 k $\Omega$	1/2 W	1%
R429	316-0221-00			220 $\Omega$	1/4 W	
R431	323-0346-00			39.2 k $\Omega$	1/2 W	Prec 1%
R432	311-0510-00			10 k $\Omega$ , Var		
R434	323-0402-00			150 k $\Omega$	1/2 W	Prec 1%
R435	321-0355-00			49.9 k $\Omega$	1/8 W	Prec 1%
R437	321-0307-00			15.4 k $\Omega$	1/8 W	Prec 1%
R438	321-0333-00			28.7 k $\Omega$	1/8 W	Prec 1%
R439	321-0349-00			42.2 k $\Omega$	1/8 W	Prec 1%
R440	316-0473-00			47 k $\Omega$	1/4 W	
R441	315-0333-00			33 k $\Omega$	1/4 W	5%
R443	315-0333-00			33 k $\Omega$	1/4 W	5%
R447	305-0473-00			47 k $\Omega$	2 W	5%

**Electrical Parts List—Type R564B**

**Resistors (cont)**

Ckt. No.	Tektronix Part No.	Serial/Model No. Eff	No. Disc	Description		
R453	323-0430-00		294 kΩ	1/2 W	Prec	1%
R454	315-0824-00		820 kΩ	1/4 W		
R456	316-0103-00		10 kΩ	1/4 W		5%
R457	316-0222-00		2.2 kΩ	1/4 W		
R459	302-0823-00		82 kΩ	1/2 W		
R462	311-0624-00		200 kΩ, Var			
R463	302-0473-00		47 kΩ	1/2 W		
R465	302-0333-00		33 kΩ	1/2 W		
R467	302-0154-00		150 kΩ	1/2 W		
R470	311-0023-00		50 kΩ, Var			
R473	302-0103-00		10 kΩ	1/2 W		
R475	311-0018-00		20 kΩ, Var			
R476	316-0822-00		8.2 kΩ	1/4 W		
R478	311-0551-00		500 kΩ, Var			

**Switches**

	Wired or Unwired			
SW1	260-0276-00		Toggle	POWER
SW2				
SW3				
SW150	Wired *262-0839-00		Rotary	1 kHz CALIBRATOR
SW150	260-0999-00		Rotary	1 kHz CALIBRATOR
SW225	260-0971-00		Push	LOCATE
SW255	260-0450-00		Slide	CRT CATHODE SELECTOR
SW300	Wired *262-0855-00		Push	STORE (Upper)
SW304				ERASE (Upper)
SW340				ENHANCE (Upper)
SW300	260-1009-00		Push	STORE (Upper)
SW304				ERASE (Upper)
SW340				ENHANCE (Upper)
SW400				STORE (Lower)
SW404	Wired *262-0855-00		Push	ERASE (Lower)
SW440				ENHANCE (Lower)
SW400				STORE (Lower)
SW404	260-1009-00		Push	ERASE (Lower)
SW440				ENHANCE (Lower)
SW480	260-0645-00		Push	INTEGRATE

**Thermal Cutout**

TK1	260-0551-00	187° F
-----	-------------	--------

\*See Mechanical Parts List. Line Voltage Selector Body (\*204-0279-00).



**Transformers**

Ckt. No.	Tektronix Part No.	Serial/Model No. Eff	No. Disc	Description
T1	*120-0575-00			L. V. Power
T220	*120-0466-00			H. V. Power

**Electron Tube**

V249	*154-0565-00		T5641-200	CRT Standard Phosphor
------	--------------	--	-----------	-----------------------

## FIGURE AND INDEX NUMBERS

Items in this section are referenced by figure and index numbers to the illustrations which appear on the pullout pages immediately following the Diagrams section of this instruction manual.

## INDENTATION SYSTEM

This mechanical parts list is indented to indicate item relationships. Following is an example of the indentation system used in the Description column.

*Assembly and/or Component*  
*Detail Part of Assembly and/or Component*  
*mounting hardware for Detail Part*  
*Parts of Detail Part*  
*mounting hardware for Parts of Detail Part*  
*mounting hardware for Assembly and/or Component*

Mounting hardware always appears in the same indentation as the item it mounts, while the detail parts are indented to the right. Indented items are part of, and included with, the next higher indentation.

**Mounting hardware must be purchased separately, unless otherwise specified.**

## PARTS ORDERING INFORMATION

Replacement parts are available from or through your local Tektronix, Inc. Field Office or representative.

Changes to Tektronix instruments are sometimes made to accommodate improved components as they become available, and to give you the benefit of the latest circuit improvements developed in our engineering department. It is therefore important, when ordering parts, to include the following information in your order: Part number, instrument type or number, serial or model number, and modification number if applicable.

If a part you have ordered has been replaced with a new or improved part, your local Tektronix, Inc. Field Office or representative will contact you concerning any change in part number.

Change information, if any, is located at the rear of this manual.

## ABBREVIATIONS AND SYMBOLS

For an explanation of the abbreviations and symbols used in this section, please refer to the page immediately preceding the Electrical Parts List in this instruction manual.

**Mechanical Parts List—Type R564B**

**List Of Mechanical Parts List Illustrations**  
**(Located behind Diagrams)**

Fig. 1 FRONT

Fig. 2 REAR

Fig. 3 ACCESSORIES

# SECTION 7

## MECHANICAL PARTS LIST

FIG. 1 FRONT

Fig. & Index No.	Tektronix Part No.	Serial/Model Eff	No. Disc	Q					Description	
				t	y	1	2	3		4
1-1	200-0426-00			1						COVER, graticule
	- - - - -			-						mounting hardware: (not included w/cover)
-2	210-0571-00			4						NUT, knurled
-3	352-0049-00			1						HOLDER, reflector
-4	378-0589-00			1						REFLECTOR
-5	378-0560-00			1						FILTER, light, smoke gray
-6	354-0181-00			1						RING, CRT shockmount
-7	331-0097-00			1						GRATICULE
-8	366-0236-00			1						KNOB, gray—SCALE ILLUM
	- - - - -			-						knob includes:
	213-0020-00			1						SCREW, set, 6-32 x 1/8 inch, HSS
-9	- - - - -			1						RESISTOR, variable
	- - - - -			-						mounting hardware: (not included w/resistor)
	210-0012-00			1						LOCKWASHER, internal, 3/8 ID x 1/2 inch OD
	210-0978-00			1						WASHER, flat, 3/8 x 1/2 inch
-10	210-0590-00			1						NUT, hex., 3/8-32 x 7/16 inch
-11	366-0322-01			1						KNOB, gray—CALIBRATOR
	- - - - -			-						knob includes:
	213-0004-00			1						SCREW, set, 6-32 x 3/16 inch, HSS
-12	262-0839-00			1						SWITCH, wired—CALIBRATOR
	- - - - -			-						switch includes:
	260-0999-00			1						SWITCH, unwired
	- - - - -			-						mounting hardware: (not included w/switch)
	210-0012-00			1						LOCKWASHER, internal, 3/8 ID x 1/2 inch OD
-13	210-0590-00			1						NUT, hex., 3/8-32 x 7/16 inch
-14	366-0153-00			1						KNOB, gray—FOCUS
	- - - - -			-						knob includes:
	213-0004-00			1						SCREW, set, 6-32 x 3/16 inch, HSS
-15	- - - - -			1						RESISTOR, variable
	- - - - -			-						mounting hardware: (not included w/resistor)
	210-0046-00			1						LOCKWASHER, internal, 1/4 ID x 0.400 inch OD
	210-0940-00			1						WASHER, flat, 1/4 ID x 3/8 inch OD
	210-0583-00			1						NUT, hex., 1/4-32 x 5/16 inch
-16	366-0236-00			1						KNOB, gray—INTENSITY
	- - - - -			-						knob includes:
	213-0020-00			1						SCREW, set, 6-32 x 1/8 inch, HSS
-17	- - - - -			1						RESISTOR, variable
	- - - - -			-						mounting hardware: (not included w/resistor)
	210-0012-00			1						LOCKWASHER, internal, 3/8 ID x 1/2 inch OD
	210-0978-00			1						WASHER, flat, 3/8 x 1/2 inch
	210-0590-00			1						NUT, hex., 3/8-32 x 7/16 inch

Mechanical Parts List—Type R564B

FIG. 1 FRONT (Cont)

Fig. & Index No.	Tektronix Part No.	Serial/Model No. Eff Disc	Q					Description
			t	Y	1	2	3	
1-18	- - - - -		2					RESISTOR, variable
	- - - - -		-					mounting hardware for each: (not included w/resistor)
	210-0013-00		1					LOCKWASHER, internal, $\frac{3}{8}$ ID x $1\frac{1}{16}$ inch OD
-19	210-0494-00		1					NUT, hex., $\frac{3}{8}$ -32 x $\frac{1}{2}$ x $1\frac{1}{16}$ inch OD
-20	358-0010-00		1					BUSHING, hex., $\frac{1}{2}$ inch long
-21	131-0274-00		1					CONNECTOR, coaxial, 1 contact BNC, w/hardware
-22	136-0223-00		1					SOCKET, light, w/green lens
	- - - - -		-					mounting hardware: (not included w/socket)
-23	210-0223-00		1					LUG, solder, $\frac{1}{4}$ ID x $\frac{7}{16}$ inch OD, SE
	210-0940-00		1					WASHER, flat, $\frac{1}{4}$ ID x $\frac{3}{8}$ inch OD
-24	210-0562-00		1					NUT, hex., $\frac{1}{4}$ -40 x $\frac{5}{16}$ inch
-25	200-0608-00		1					COVER, variable resistor
-26	136-0264-00		3					SOCKET, graticule light
	- - - - -		-					mounting hardware for each: (not included w/socket)
-27	211-0590-00		1					SCREW, 6-32 x $\frac{1}{4}$ inch, non-magnetic, PHS
	210-0457-00		1					NUT, keps, 6-32 x $\frac{5}{16}$ inch
-28	348-0056-00		3					GROMMET, plastic, $\frac{3}{8}$ inch
-29	333-1088-01		1					PANEL, front
-30	367-0032-00		2					HANDLE
	- - - - -		-					mounting hardware for each: (not included w/handle)
-31	212-0557-00		2					SCREW, 10-32 x $\frac{1}{2}$ inch, RHS
-32	386-1426-00		1					PLATE, sub-panel, front
	- - - - -		-					plate includes:
-33	355-0043-00		4					STUD, graticule (replacement)
	- - - - -		-					each stud includes:
	212-0507-00		1					SCREW, 10-32 x $\frac{3}{8}$ inch, PHS
	210-0010-00		1					LOCKWASHER, internal, #10
-34	407-0466-00		1					BRACKET
	- - - - -		-					mounting hardware: (not included w/bracket)
-35	211-0538-00		1					SCREW, 6-32 x $\frac{5}{16}$ inch, 100° csk, FHS
	210-0457-00		1					NUT, keps, 6-32 x $\frac{5}{16}$ inch
	212-0004-00		2					SCREW, 8-32 x $\frac{5}{16}$ inch, PHS
	210-0458-00		2					NUT, keps, 8-32 x $1\frac{1}{32}$ inch
-36	337-1027-00		1					SHIELD
	- - - - -		-					mounting hardware: (not included w/shield)
-37	211-0507-00		3					SCREW, 6-32 x $\frac{5}{16}$ inch, PHS
	210-0803-00		3					WASHER, flat, 0.150 ID x $\frac{3}{8}$ inch, OD
-38	407-0473-00		2					BRACKET
	- - - - -		1					mounting hardware: (not included w/bracket)
-39	211-0538-00		1					SCREW, 6-32 x $\frac{5}{16}$ inch, 100° csk, FHS
	210-0457-00		1					NUT, keps, 6-32 x $\frac{5}{16}$ inch
	212-0004-00		2					SCREW, 8-32 x $\frac{5}{16}$ inch, PHS
	210-0458-00		2					NUT, keps, 8-32 x $1\frac{1}{32}$ inch

FIG. 1 FRONT (Cont)

Fig. & Index No.	Tektronix Part No.	Serial/Model No. Eff Disc	Q t y	1 2 3 4 5					Description
				1	2	3	4	5	
1-40	337-1032-00		1						SHIELD
	- - - - -		-						mounting hardware: (not included w/shield)
-41	211-0507-00		3						SCREW, 6-32 x 5/16 inch, PHS
-42	210-0803-00		2						WASHER, flat, 0.150 ID x 3/8 inch OD
-43	337-1021-01		1						SHIELD, CRT
	- - - - -		-						mounting hardware: (not included w/shield)
-44	211-0590-00		4						SCREW, 6-32 x 1/4 inch, PHS, non-magnetic
	210-0586-00		4						NUT, keps, 4-40 x 1/4 inch
	- - - - -		1						COIL
	- - - - -		-						mounting hardware: (not included w/coil)
-46	352-0044-00		1						HOLDER, coil
	211-0148-00		1						SCREW, 4-40 x 5/16 inch, PHS, non-magnetic
	210-0586-00		1						NUT, keps, 4-40 x 1/4 inch
-47	343-0138-00		1						CLAMP, CRT retainer, black
-48	343-0171-01		1						CLAMP, CRT retainer, tapped
-49	343-0123-01		1						CLAMP, CRT retainer
-50	211-0146-00		1						SCREW, 4-40 x 1.312 inch Filister HS
-51	211-0590-00		4						SCREW, 6-32 x 1/4 inch, PHS
-53	211-0599-00		2						SCREW, 6-32 x 3/4 inch Filister HS
-54	220-0444-00		2						NUT, square, 6-32 x 1/4 inch
-55	358-0215-00		1						BUSHING, u-shaped
-56	175-0588-00		1						CRT LEAD, striped orange
	175-0641-00		1						CRT LEAD, brown
	175-0642-00		1						CRT LEAD, blue
	175-0705-00		1						CRT LEAD, green
	175-0706-00		1						CRT LEAD, red
-57	406-0716-00		2						BRACKET, plug-in
	- - - - -		-						mounting hardware for each: (not included w/bracket)
-58	211-0538-00		2						SCREW, 6-32 x 5/16 inch, 100° csk, FHS
-59	210-0457-00		2						NUT, keps, 6-32 x 5/16 inch
	212-0004-00		2						SCREW, 8-32 x 5/16 inch
	210-0458-00		2						NUT, keps, 8-32 x 1 1/32 inch
-60	351-0047-00		2						GUIDE, plug-in
	- - - - -		-						mounting hardware for each: (not included w/guide)
-61	211-0541-00		2						SCREW, 6-32 x 1/4 inch, 100° csk, FHS
-62	387-0449-00		1						PLATE, right side cover
	- - - - -		-						mounting hardware: (not included w/plate)
-63	211-0504-00		4						SCREW, 6-32 x 1/4 inch, PHS
-64	211-0538-00		2						SCREW, 6-32 x 5/16 inch, 100° csk, FHS
-65	390-0048-00		1						CABINET SIDE, right
	- - - - -		-						mounting hardware: (not included w/cabinet side)
-66	212-0070-00		6						SCREW, 6-32 x 5/16 inch, 100° csk, FHS
	210-0458-00		6						NUT, keps, 8-32 x 1 1/32 inch

Mechanical Parts List—Type R564B

FIG. 1 FRONT (Cont)

Fig. & Index No.	Tektronix Part No.	Serial/Model No. Eff Disc	Q					Description
			t y	1	2	3	4	
1-67	387-0450-00		1					PLATE, left side cover
	- - - - -		-					mounting hardware: (not included w/plate)
-68	211-0504-00		4					SCREW, 6-32 x 1/4 inch, PHS
-69	211-0538-00		2					SCREW, 6-32 x 1/4 inch, 100° csk, FHS
-70	390-0047-00		1					CABINET SIDE, left
	- - - - -		-					mounting hardware: (not included w/cabinet side)
-71	212-0070-00		6					SCREW, 8-32 x 5/16 inch, 100° csk, FHS
-72	210-0458-00		6					NUT, keps, 8-32 x 1 1/32 inch
-73	387-0452-00		2					PLATE, dust cover
	- - - - -		-					mounting hardware for each: (not included w/cabinet)
-74	211-0504-00		9					SCREW, 6-32 x 1/4 inch, PHS
-75	131-0637-00		1					ASSEMBLY, wall band
	- - - - -		-					assembly includes:
	131-0371-00		6					Connector, single contact, female
	- - - - -		-					mounting hardware: (not included w/assembly)
-76	211-0147-00		3					SCREW, 4-40 x 1/4 inch, PHS, non-magnetic
	210-0801-00		3					WASHER, flat, 0.140 ID x 0.281 inch OD
-77	210-0586-00		3					NUT, keps, 4-40 x 1/4 inch
-78	366-0153-00		1					KNOB, gray—LEVEL
	- - - - -		-					knob includes:
	213-0004-00		1					SCREW, set, 6-32 x 3/16 inch, HSS
-79	- - - - -		-					RESISTOR, variable
	- - - - -		-					mounting hardware: (not included w/resistor)
	210-0046-00		1					LOCKWASHER, internal, 1/4 ID x 0.400 inch OD
	210-0940-00		1					WASHER, flat, 1/4 ID x 3/8 inch OD
	210-0583-00		1					NUT, hex., 1/4-32 x 5/16 inch
-80	260-0645-00		1					SWITCH, push—INTEGRATE
	- - - - -		-					mounting hardware: (not included w/switch)
-81	210-0590-00		1					NUT, hex., 3/8-32 x 7/16 inch
-82	210-0978-00		1					WASHER, flat, 3/8 ID x 1/2 inch OD
-83	210-0012-00		1					LOCKWASHER, internal, 3/8 ID x 1/2 inch OD
-84	260-0971-00		1					SWITCH, push—LOCATE
	- - - - -		-					mounting hardware: (not included w/switch)
-85	210-0590-00		1					NUT, hex., 3/8-32 x 7/16 inch
	210-0978-00		1					WASHER, flat, 3/8 ID x 1/2 inch OD
	210-0012-00		1					LOCKWASHER, internal, 3/8 ID x 1/2 inch OD
-86	366-1049-00		2					KNOB, gray—STORE
-87	366-1050-00		2					KNOB, gray—ENHANCE
-88	366-1051-00		2					KNOB, gray—ERASE

FIG. 1 FRONT (Cont)

Fig. & Index No.	Tektronix Part No.	Serial/Model No.		Q † Y	1	2	3	4	5	Description
		Eff	Disc							
1-	262-0855-00			1						ASSEMBLY, interface switch
	- - - - -			-						assembly includes:
	670-0604-00			2						ASSEMBLY, circuit board
	- - - - -			-						each assembly includes:
-89	388-1027-00			1						BOARD, circuit
-90	260-1009-00			1						SWITCH, push—STORE, ENHANCE, ERASE
-91	361-0228-00			3						SPACER, square
-92	179-1331-00			1						CABLE HARNESS
-93	407-0476-00			1						BRACKET
-94	211-0145-00			4						SCREW, sems, 4-40 x 1 inch
	210-1001-00			4						WASHER, flat, 0.125 ID x 0.250 inch OD
-95	210-0586-00			4						NUT, keps, 4-40 x 1/4 inch
	- - - - -			-						mounting hardware: (not included w/assembly)
-96	220-0413-00			3						NUT, hex., 4-40 x 0.562 inch long
-97	348-0004-00			1						GROMMET, rubber, 3/16 inch diameter
-96	220-0413-00			2						BOLT, current loop
-98	214-0335-00			1						mounting hardware: (not included w/bolt)
	- - - - -			-						LOCKWASHER, internal, #4
	210-0004-00			1						LUG, solder, SE #4
	210-0442-00			2						NUT, hex., 3-48 x 3/16 inch
	210-0849-00			1						WASHER, fiber, #4 shouldered
-99	210-0593-00			2						NUT, Current Loop
-100	361-0059-00			1						SPACER, Current Loop



Mechanical Parts List—Type R564B

FIG. 2 REAR

Fig. & Index No.	Tektronix Part No.	Serial/Model Eff	No. Disc	Q					Description	
				†	y	1	2	3		4
2-1	441-0802-00			1						CHASSIS, storage
	- - - - -			-						mounting hardware: (not included w/chassis)
-2	212-0002-00			2						SCREW, 8-32 x 1/4 inch, 100° csk, FHS
-3	212-0004-00			2						SCREW, 8-32 x 5/16 inch, PHS
	210-0458-00			2						NUT, keps, 8-32 x 3/8 inch
	211-0507-00			2						SCREW, 6-32 x 5/16, PHS
-4	210-0457-00			2						NUT, keps, 6-32 x 5/16 inch
	212-0001-00			2						SCREW, 8-32 x 1/4 inch, PHS
	212-0070-00			2						SCREW, 8-32 x 5/16 inch, 100° csk, FHS
-5	441-0792-00			1						CHASSIS, power supply
	- - - - -			-						mounting hardware: (not included w/chassis)
-6	212-0004-00			6						SCREW, 8-32 x 5/16 inch, PHS
-7	386-1445-00			1						PANEL, rear
	- - - - -			-						mounting hardware: (not included w/panel)
-8	212-0004-00			4						SCREW, 8-32 x 5/16 inch, PHS
	210-0458-00			4						NUT, keps, 8-32 x 1 1/32 inch
	670-0611-00			1						ASSEMBLY, circuit board—STORAGE
	- - - - -			-						assembly includes:
-9	388-1032-00			1						BOARD, circuit
-10	131-0633-00			41						TERMINAL PIN
-11	136-0183-00			6						SOCKET, 3 pin
-12	136-0220-00			6						SOCKET, transistor, 3 pin
	- - - - -			-						mounting hardware: (not included w/assembly)
-13	211-0601-00			4						SCREW, sems 6/32 x 1/4 inch, PHS
-14	385-0168-00			4						ROD, spacer, 1/4 inch hex., x 1.168 inches long
	- - - - -			-						mounting hardware: (not included w/rod)
-15	210-0006-00			4						LOCKWASHER, internal, #6
-16	211-0507-00			4						SCREW, 6-32 x 5/16 inch, PHS
-17	344-0095-00			2						CLIP, ground
	- - - - -			-						mounting hardware for each: (not included w/clip)
-18	210-0457-00			1						NUT, keps, 6-32 x 5/16 inch
-19	211-0541-00			1						SCREW, 6-32 x 1/4 inch, 100° csk, FHS
-20	- - - - -			2						RESISTOR, variable
	- - - - -			-						mounting hardware for each: (not included w/resistor)
-21	210-0012-00			1						LOCKWASHER, internal, 3/8 ID x 1/2 inch OD
-22	210-0978-00			1						WASHER, flat, 3/8 ID x 1/2 inch OD
-23	210-0590-00			1						NUT, hex., 3/8-32 x 1/2 inch

FIG. 2 REAR (Cont)

Fig. & Index No.	Tektronix Part No.	Serial/Model Eff	No. Disc	Q					Description
				y	1	2	3	4	
2-24	- - - - -			4					CAPACITOR
	- - - - -			-					mounting hardware for each: (not included w/capacitor)
-25	432-0048-00			1					BASE, capacitor mounting
-26	386-0254-00			1					PLATE, fiber, large
-27	211-0516-00			2					SCREW, 6-32 x 3/4 inch, PHS
-28	210-0457-00			2					NUT, keps, 6-32 x 5/16 inch
-29	200-0259-00			3					COVER, capacitor, plastic, 1.365 ID x 3 9/16 inches long
-30	- - - - -			1					CAPACITOR
	- - - - -			-					mounting hardware: (not included w/capacitor)
-31	386-0253-00			1					PLATE, metal, small
-32	211-0534-00			2					SCREW, sems, 6-32 x 5/16 inch, PHS
	210-0457-00			2					NUT, keps, 6-32 x 5/16 inch
-33	343-0005-00	B010100	B040259	2					CLAMP, cable, 5/16 inch diameter
	343-0042-00	B040260		2					CLAMP, cable, 7/16 inch diameter
	- - - - -			-					mounting hardware for each: (not included w/clamp)
-34	211-0507-00			1					SCREW, 6-32 x 5/16 inch, PHS
	210-0802-00			1					WASHER, flat, 0.150 ID x 5/16 inch OD
-35	210-0457-00			1					NUT, keps, 6-32 x 5/16 inch
-36	179-1327-00			1					CABLE, HARNESS, power
	- - - - -			-					cable harness includes:
-37	131-0371-00			46					CONNECTOR, single contact, female
-38	351-0158-00			2					GUIDE, shaft
	- - - - -			-					mounting hardware for each: (not included w/guide)
-39	361-0009-00			1					SPACER, nylon
-40	385-0138-00			2					ROD, plastic
	- - - - -			-					mounting hardware for each: (not included w/rod)
-41	213-0054-00			1					SCREW, thread cutting, 6-32 x 5/16 inch, PHS
-42	385-0075-00			3					ROD, plastic
	- - - - -			-					mounting hardware for each: (not included w/rod)
-43	213-0054-00			1					SCREW, thread cutting, 6-32 x 5/16 inch, PHS
-44	276-0008-00			1					COIL FORM
	- - - - -			-					mounting hardware: (not included w/coil form)
-45	213-0045-00			1					SCREW, thread forming, 4-40 x 5/16 inch, PHS

Mechanical Parts List—Type R564B

FIG. 2 REAR (Cont)

Fig. & Index No.	Tektronix Part No.	Serial/Model Eff	No. Disc	Q † y						Description
					1	2	3	4	5	
2-46	131-0148-00			2						CONNECTOR, 24 pin
	- - - - -			-						mounting hardware for each: (not included w/connector)
-47	211-0016-00			2						SCREW, 4-40 x 5/8 inch, PHS
-48	166-0030-00			2						TUBE, spacer, 0.180 ID x 3/16 inch long
-49	210-0586-00			2						NUT, keps, 4-40 x 1/4 inch
-50	252-0564-00			IN.						CHANNEL, plastic, 10 1/2 inches
-51	124-0162-00			1						STRIP, ceramic, 7/16 inch h, w/4 notches
	- - - - -			-						each strip includes:
-52	355-0046-00			2						STUD, plastic
	- - - - -			-						mounting hardware: (not included w/strip)
-53	361-0007-00			2						SPACER, plastic
-54	- - - - -			1						THERMAL CUTOUT
	- - - - -			-						mounting hardware: (not included w/thermal cutout)
-55	211-0541-00	B010100	B020149	2						SCREW, 6-32 x 1/4 inch, 100° csk, FHS
	210-0006-00	B010100	B020149	2						LOCKWASHER, internal, #6
	210-0407-00	B010100	B020149	2						NUT, hex., 6-32 x 1/4 inch
	210-0586-00	B020150		2						NUT, keps, 4-40 x 1/4 inch
-56	670-0610-00			1						ASSEMBLY, circuit board—POWER SUPPLY
	- - - - -			-						assembly includes:
	388-1031-00			1						BOARD, circuit
-57	131-0633-00			47						TERMINAL PIN
-58	136-0183-00			7						SOCKET, transistor
-59	136-0220-00			9						SOCKET, transistor
-60	136-0235-00			4						SOCKET, semi-conductor device
-61	343-0043-00			1						CLAMP, neon bulb
-62	344-0154-00			2						HOLDER, fuse
	- - - - -			-						mounting hardware: (not included w/assembly)
-63	211-0601-00			4						SCREW, sems, 6-32 x 5/16 inch, PHB
-64	385-0168-00			2						ROD, spacer, 1/4 inch, hex., x 1.168 inches long
	- - - - -			-						mounting hardware for each: (not included w/rod)
-65	210-0006-00			1						LOCKWASHER, internal, #6
	211-0538-00			1						SCREW, 6-32 x 5/16 inch, FHS
-66	385-0146-00			2						ROD, spacer, 1/4 inch, hex., x 0.700 inch long
	- - - - -			-						mounting hardware for each: (not included w/rod)
	210-0006-00			1						LOCKWASHER, internal, #6
	211-0507-00			1						SCREW, 6-32 x 5/16 inch, PHS
-67	- - - - -			1						RESISTOR, variable
	- - - - -			-						mounting hardware: (not included w/resistor)
-68	210-0940-00			1						WASHER, flat, 1/4 ID x 3/8 inch OD
	210-0046-00			1						LOCKWASHER, internal, 1/4 ID x 0.400 inch OD
	210-0583-00			1						NUT, hex., 1/4-32 x 5/16 inch
-69	- - - - -			1						TRANSISTOR
	- - - - -			-						mounting hardware: (not included w/transistor)
-70	213-0183-00			2						SCREW, thread forming, 6-32 x 1/2 inch, PHS

FIG. 2 REAR (Cont)

Fig. & Index No.	Tektronix Part No.	Serial/Model Eff	No. Disc	Q					Description	
				t	y	1	2	3		4
2-71	- - - - -			2						TRANSISTOR
	- - - - -			-						mounting hardware for each: (not included w/transistor)
-72	213-0183-00			2						SCREW, thread forming, 6-32 x 1/2 inch, PHS
-73	386-0143-00			1						PLATE, mica insulator
-74	- - - - -			2						TRANSISTOR
	- - - - -			-						mounting hardware for each: (not included w/transistor)
-75	213-0183-00			2						SCREW, thread forming, 6-32 x 1/2 inch, PHS
-76	386-0978-00			1						PLATE, mica insulator
-77	136-0280-00			3						SOCKET, transistor
	- - - - -			-						mounting hardware for each: (not included w/socket)
-78	213-0088-00			2						SCREW, thread forming, 4-40 x 1/4 inch, PHS
-79	136-0280-00			2						SOCKET, transistor
	- - - - -			-						mounting hardware for each: (not included w/socket)
-80	213-0088-00			2						SCREW, thread forming, 4-40 x 1/4 inch, PHS
-81	200-0608-00			1						COVER, plastic, variable resistor
-82	- - - - -			1						RESISTOR
	- - - - -			-						mounting hardware: (not included w/resistor)
-83	211-0553-00			1						SCREW, 6-32 x 1 1/2 inches, RHS
-84	210-0601-00			1						EYELET
-85	210-0478-00			1						NUT, hex., 5/16 x 2 1/32 inch long
-86	211-0507-00			1						SCREW, 6-32 x 5/16 inch, PHS
-87	210-0204-00			2						LUG, solder, DE #6
	- - - - -			-						mounting hardware for each: (not included w/lug)
-88	211-0541-00			1						SCREW, 6-32 x 1/4 inch, 100° csk, FHS
	210-0407-00			1						NUT, 6-32 x 1/4 inch
-89	200-0900-00			1						COVER, transformer terminals
-90	- - - - -			1						TRANSFORMER
	- - - - -			-						transformer includes:
-91	212-0522-00			4						SCREW, 10-32 x 2 1/2 inches, HHS
-92	210-0812-00			4						WASHER, fiber, #10
	- - - - -			-						mounting hardware: (not included w/transformer)
-93	220-0410-00			4						NUT, keps, 10-32 x 3/8 inch
-94	136-0089-00			1						CONNECTOR, 9 contact
	- - - - -			-						mounting hardware: (not included w/connector)
-95	211-0013-00			4						SCREW, 4-40 x 3/8 inch, PHS
-96	210-0586-00			4						NUT, keps, 4-40 x 1/4 inch
-97	131-0126-00			1						CONNECTOR, coaxial, 1 contact, BNC, w/hardware
	- - - - -			-						mounting hardware: (not included w/connector)
	210-0241-00			1						LUG, solder, 0.515 ID x 0.625 inch OD

Mechanical Parts List—Type R564B

FIG. 2 REAR (Cont)

Fig. & Index No.	Tektronix Part No.	Serial/Model No. Eff Disc	Q					Description	
			t	y	1	2	3		4
2-98	134-0067-00		9						PLUG, plastic, gray
-99	119-0031-00		1						ASSEMBLY, blower
-100	351-0046-00		2						GUIDE, clip, fan
	- - - - -		-						mounting hardware for each: (not included w/guide)
-101	211-0541-00		4						SCREW, 6-32 x 1/4 inch, 100° csk, FHS
-102	210-0457-00		4						NUT, keps, 6-32 x 5/16 inch
-103	378-0761-00		1						SCREEN, grille
-104	200-0762-00		1						COVER, line voltage selector
	- - - - -		-						cover includes:
-105	352-0102-00		2						HOLDER, fuse
	- - - - -		-						mounting hardware for each: (not included w/holder)
	213-0035-00		2						SCREW, thread cutting, 4-40 x 1/4 inch, PHS
-106	204-0279-00		1						ASSEMBLY, line voltage selector
	- - - - -		-						mounting hardware: (not included w/assembly)
-107	210-0407-00		2						NUT, hex., 6-32 x 1/4 inch
	210-0006-00		2						LOCKWASHER, internal, #6
-108	358-0161-00		1						BUSHING, strain relief
-109	161-0046-00		1						CORD, power, 3 conductor
-110	384-0439-00		1						ROD, extension, w/knob
-111	376-0053-00		1						COUPLING, rod
	- - - - -		-						coupling includes:
	213-0048-00		2						SCREW, set, 4-40 x 1/8 inch, HHS
-112	384-0702-00		1						ROD, extension, 1/8 OD x 2 1/2 inches long
-113	260-0276-00		1						SWITCH, toggle, POWER
	- - - - -		-						mounting hardware: (not included w/switch)
-114	354-0055-00		1						RING, locking switch
-115	210-0473-00		1						NUT, switch, 12 sided
-116	354-0285-00		1						RING, locking
-117	407-0467-00		1						BRACKET, toggle switch
	- - - - -		-						mounting hardware: (not included w/bracket)
-118	211-0504-00		2						SCREW, 6-32 x 1/4 inch, PHS
-119	406-0949-00		1						BRACKET
	- - - - -		-						mounting hardware: (not included w/bracket)
-120	210-0586-00		2						NUT, keps, 4-40 x 1/4 inch
-121	103-0056-00		1						ADAPTER, switch actuator
-122	129-0072-00		1						POST
	- - - - -		-						mounting hardware: (not included w/post)
-123	361-0007-00		1						SPACER, nylon

FIG. 2 REAR (Cont)

Fig. & Index No.	Tektronix Part No.	Serial/Model Eff	No. Disc	Q t y						Description
					1	2	3	4	5	
2-	621-0436-00			1						ASSEMBLY, high voltage
-	- - - - -			-						assembly includes:
-124	136-0308-00			1						ASSEMBLY, CRT socket
-	- - - - -			-						assembly includes:
	136-0304-00			1						SOCKET, CRT
-125	200-0714-00			1						COVER, high voltage box
-	- - - - -			-						mounting hardware: (not included w/cover)
-126	211-0529-00			2						SCREW, 6-32 x 1 1/4 inches, PHS
-127	211-0510-00			1						SCREW, 6-32 x 3/8 inch, PHS
-128	670-0607-00			1						ASSEMBLY, circuit board (lower)
-	- - - - -			-						assembly includes:
	388-1030-00			1						BOARD, circuit
-	- - - - -			-						mounting hardware: (not included w/board)
-129	211-0040-00			4						SCREW, 4-40 x 1/4 inch, BH plastic
-130	670-0609-00			1						ASSEMBLY, circuit board (upper)
-	- - - - -			-						assembly includes:
	388-1029-00			1						BOARD, circuit
-	- - - - -			-						mounting hardware: (not included w/board)
-131	211-0040-00			4						SCREW, 4-40 x 1/4 inch, BH plastic
-132	361-0137-00			4						SPACER
-133	214-0931-00	B010100	B029999X	2						RETAINER, component
	346-0032-00	B010100	B029999X	1						STRAP, mousetail, rubber (not shown)
-134	166-0319-00			4						SPACER, plastic
-135	380-0115-00			1						HOUSING
-	- - - - -			-						mounting hardware: (not included w/assembly)
	211-0507-00			3						SCREW, 6-32 x 5/16 inch, PHS
-136	337-0889-00			1						SHIELD, high voltage
-	- - - - -			-						mounting hardware: (not included w/shield)
	210-0457-00			2						NUT, keps, 6-32 x 5/16 inch
-137	337-0971-00			1						SHIELD, high voltage
-	- - - - -			-						mounting hardware: (not included w/shield)
-138	211-0504-00			2						SCREW, 6-32 x 1/4 inch, PHS
-139	200-0917-00			1						COVER, CRT socket
-140	337-1046-01			1						SHIELD, CRT socket
-141	367-0095-00			1						HANDLE, CRT socket
-142	260-0450-00			1						SWITCH, slide
-	- - - - -			-						mounting hardware: (not included w/switch)
-143	210-0406-00			2						NUT, hex., 4-40 x 1/4 inch
-144	179-1329-00			1						CABLE HARNESS, high voltage
-	- - - - -			-						cable harness includes:
-145	131-0371-00			4						CONNECTOR, single contact, female
-146	348-0055-00			1						GROMMET, plastic, 1/4 inch
-147	348-0056-00			2						GROMMET, plastic, 3/8 inch
-148	348-0063-00			3						GROMMET, plastic, 1/2 inch

Mechanical Parts List—Type R564B

FIG. 2 REAR (Cont)

Fig. & Index No.	Tektronix Part No.	Serial/Model No. Eff	No. Disc	Q t y						Description
					1	2	3	4	5	
2-149	343-0042-00			2						CLAMP, cable, 5/16 inch (1/2 clamp)
	- - - - -			-						mounting hardware for each: (not included w/clamp)
-150	210-0457-00			1						NUT, keps, 6-32 x 5/16 inch
	210-0802-00			1						WASHER, flat, 0.150 ID x 5/16 inch OD
	211-0507-00			1						SCREW, 6-32 x 5/16 inch, PHS
-151	179-1328-00			1						CABLE HARNESS, line voltage selector
	- - - - -			-						cable harness includes:
-152	214-0768-00			8						CONTACT, electrical, female
-153	348-0064-00			1						GROMMET, plastic, 5/8 inch
-154	386-1422-00			1						SUPPORT, chassis shield
-155	200-0176-00			1						COVER, clip

# SECTION 8

## DIAGRAMS

The following special symbols are used on the diagrams:

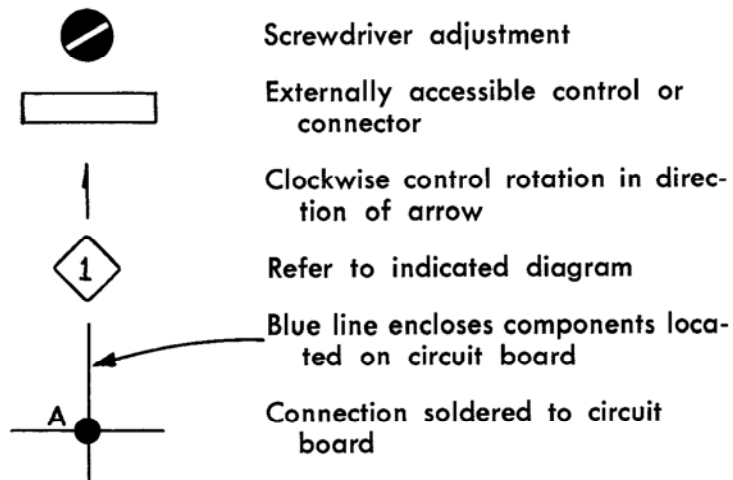

### IMPORTANT

#### VOLTAGE AND WAVEFORM CONDITIONS

Circuit voltages measured with an electronic voltmeter, having an input resistance of  $100\text{ M}\Omega$ ,  $\pm 5\%$ , and a meter accuracy of  $\pm 2\%$ . Voltages are measured with respect to chassis ground unless otherwise noted. If a  $20,000\ \Omega/\text{volt}$  VOM is used, the effects of circuit loading at high impedance points must be taken into consideration.

Waveforms shown are actual photographs taken with a Tektronix Oscilloscope Camera System and Projected Graticule.

Voltages and waveforms on the schematics (shown in blue) are not absolute and may vary between instruments because of component tolerances (or possible circuit loading of the voltmeter).

The test oscilloscope used had the following characteristics: Minimum deflection factor, 0.1 volts/division using a  $10\times$  probe; frequency response, DC to 10 MHz. DC input coupling was used.

(Cont on next diagram)



Voltage readings and waveforms were obtained under the following conditions unless otherwise noted on the individual diagrams:

**TYPE R564B**

INTENSITY	Counterclockwise
FOCUS	Centered
SCALE ILLUM	Counterclockwise
ASTIGMATISM	Centered
CALIBRATOR	40 V
STORE (upper)	Store (in)
ENHANCE (either)	On (in)
Enhance LEVEL	Counterclockwise
CRT CATHODE SELECTOR	NORM

**Amplifier Unit**

Position	Centered
Mode	Normal (Channel 1)
Volts/Div	5
Input Coupling	GND

**Time-Base Unit**

Position	Centered
Time/Div	1 ms
Sweep Mode	Normal
Level	Free run (clockwise)
Triggering Source	Internal
Triggering Slope	+
Triggering Coupling	Auto
Line Voltage	115 VAC
Signal Applied	None



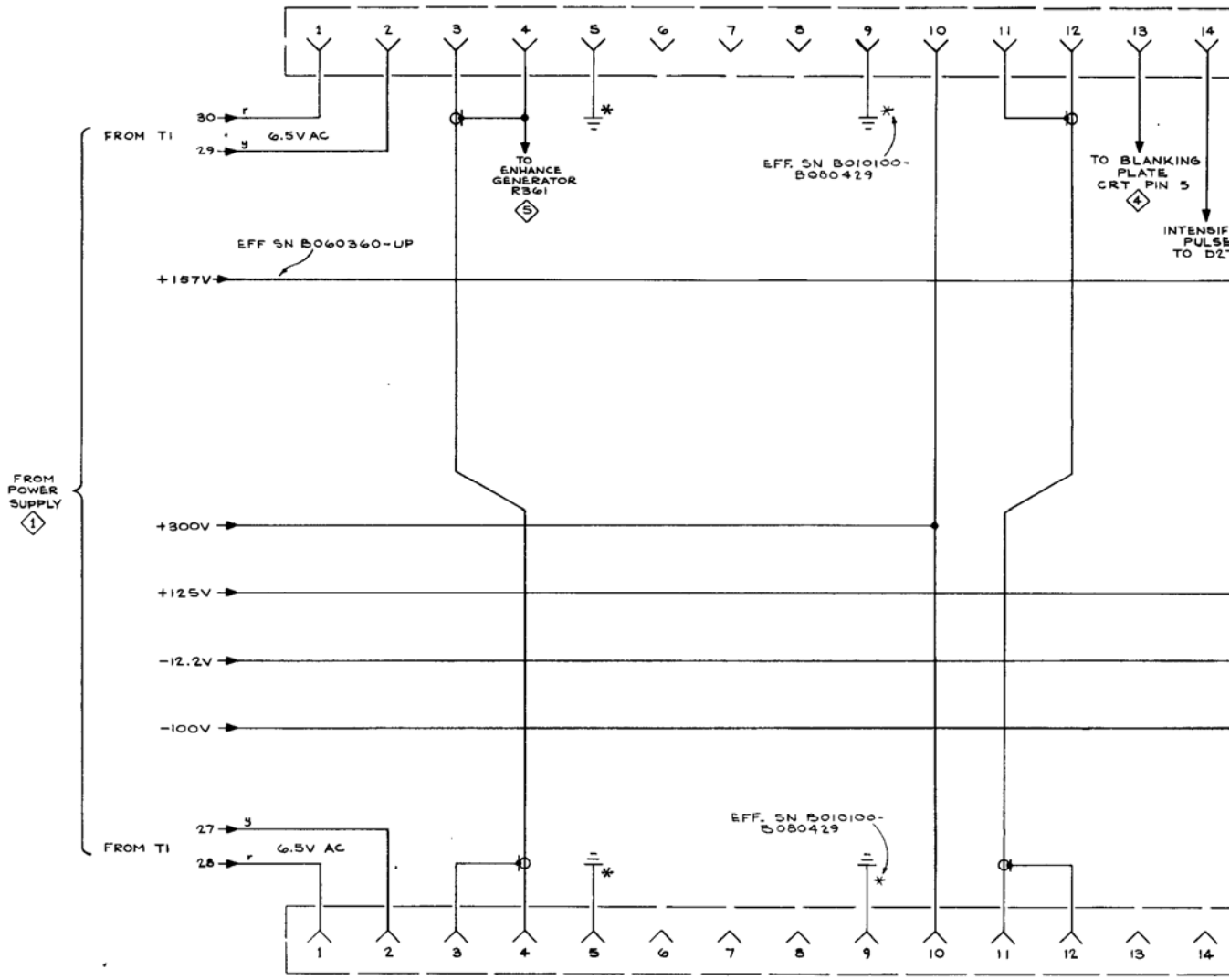

\* RETURNED TO COMMON GROUND POINT NEAR Q51

+ TYPE R564B

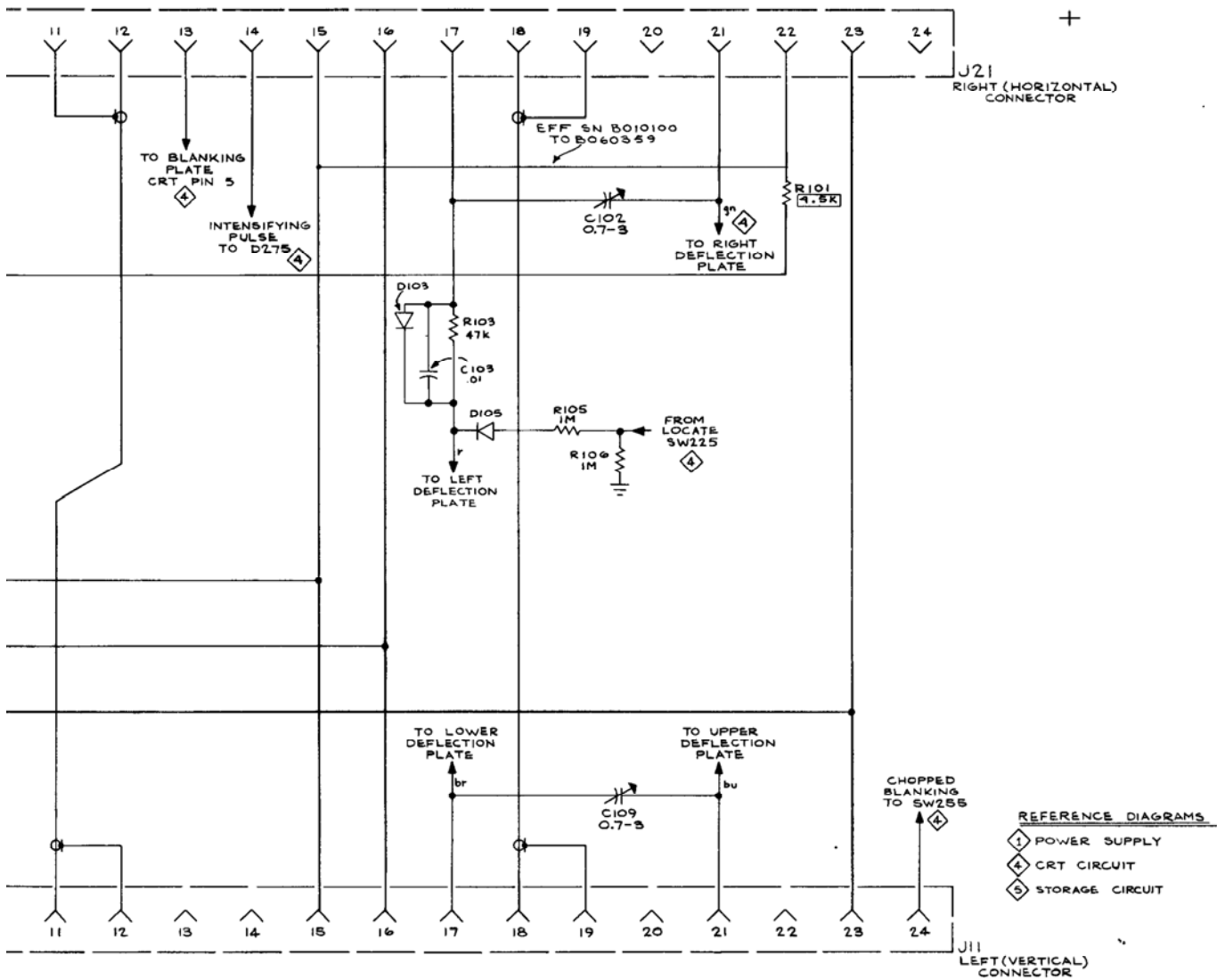

SEE PARTS LIST FOR EARLIER  
VALUES AND SERIAL NUMBER  
RANGES OF PARTS MARKED  
WITH BLUE OUTLINE.

869  
PLUG-IN CONNECTORS 2

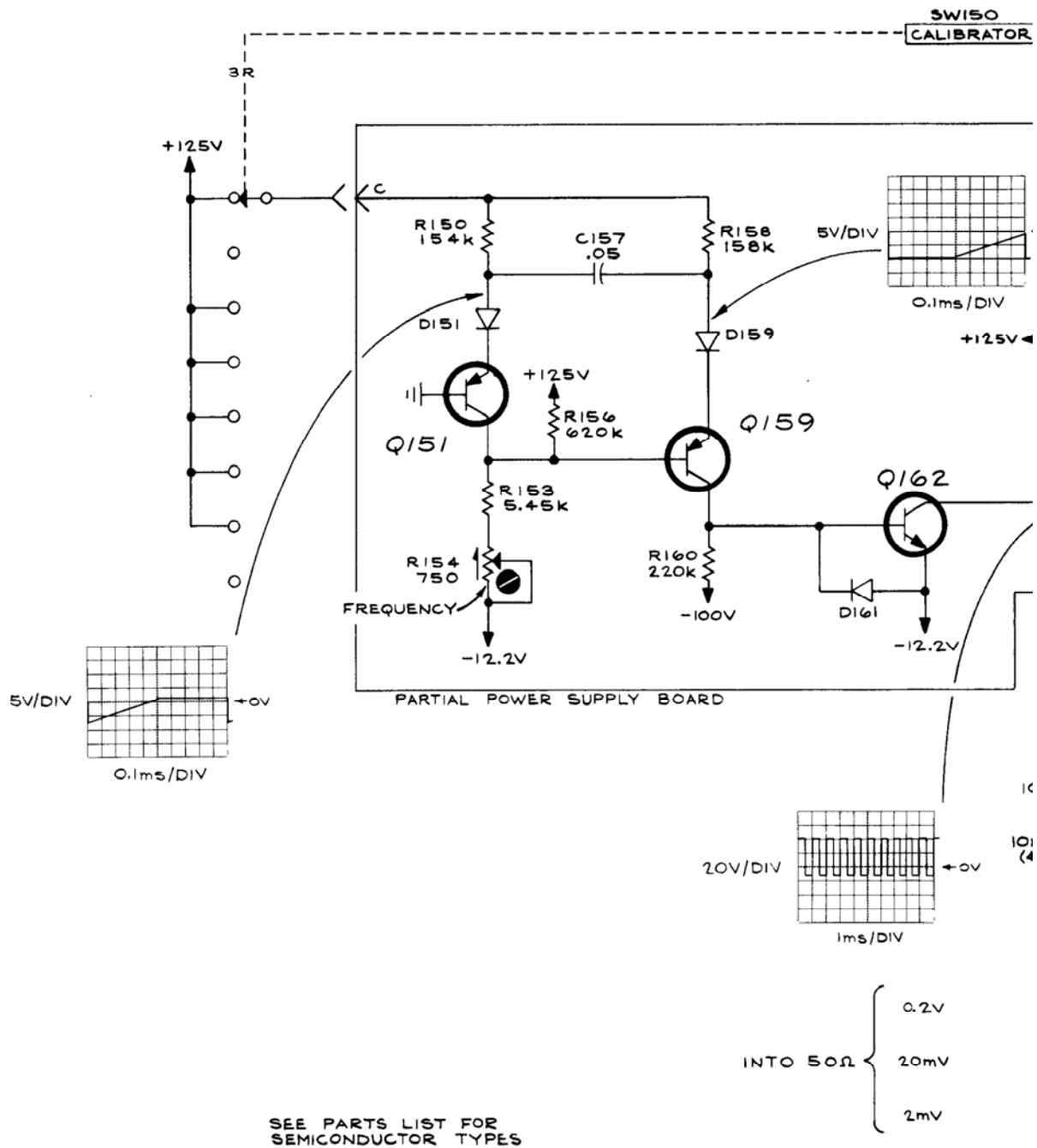

TYPE R564B

VOLTAGES and WAVEFORMS obtained under conditions given on Diagram  $\diamond$ .

A

SW150  
CALIBRATOR

2F 2R 1F&R

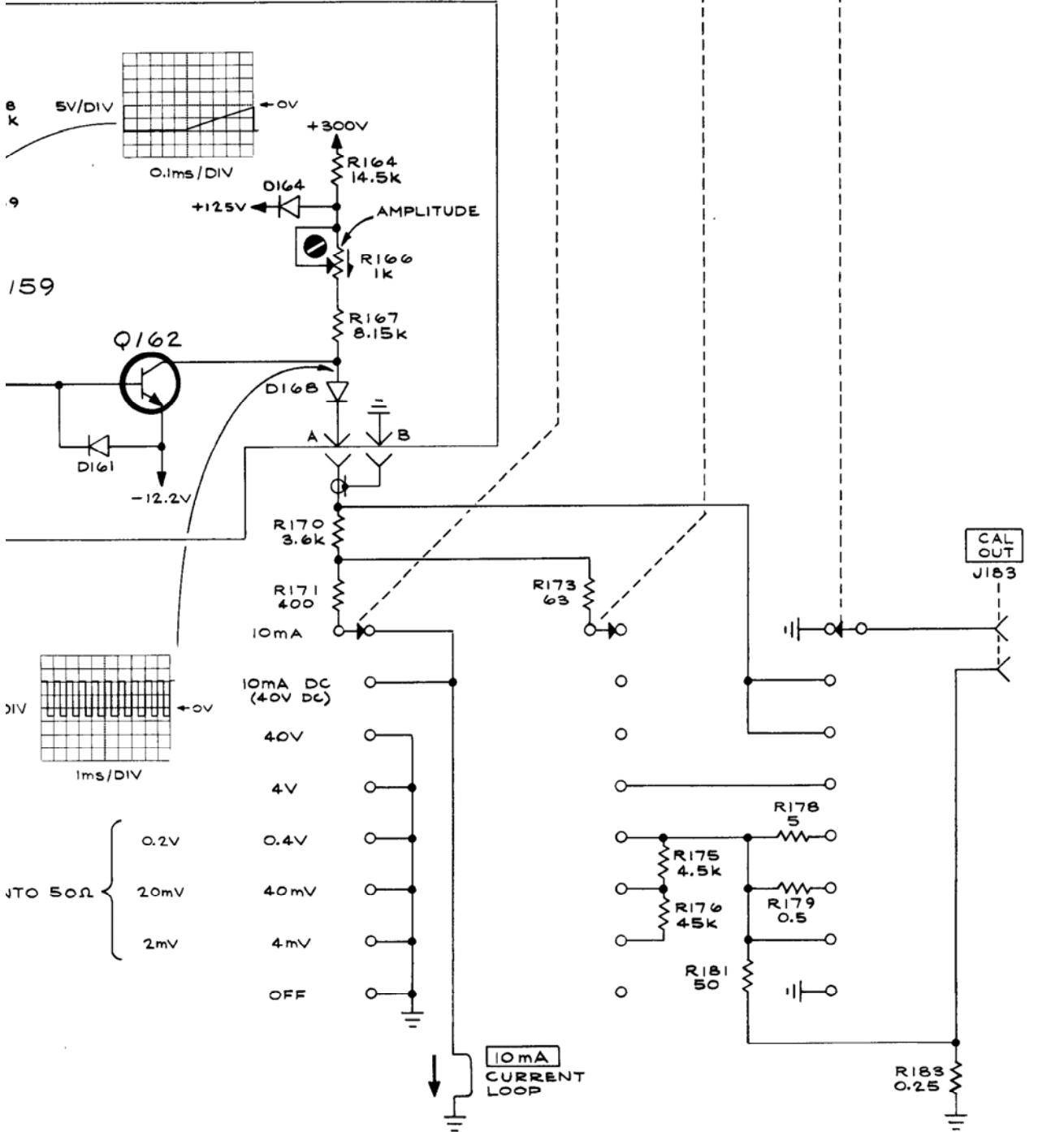

1kHz CALIBRATOR 3

868

ained under

A

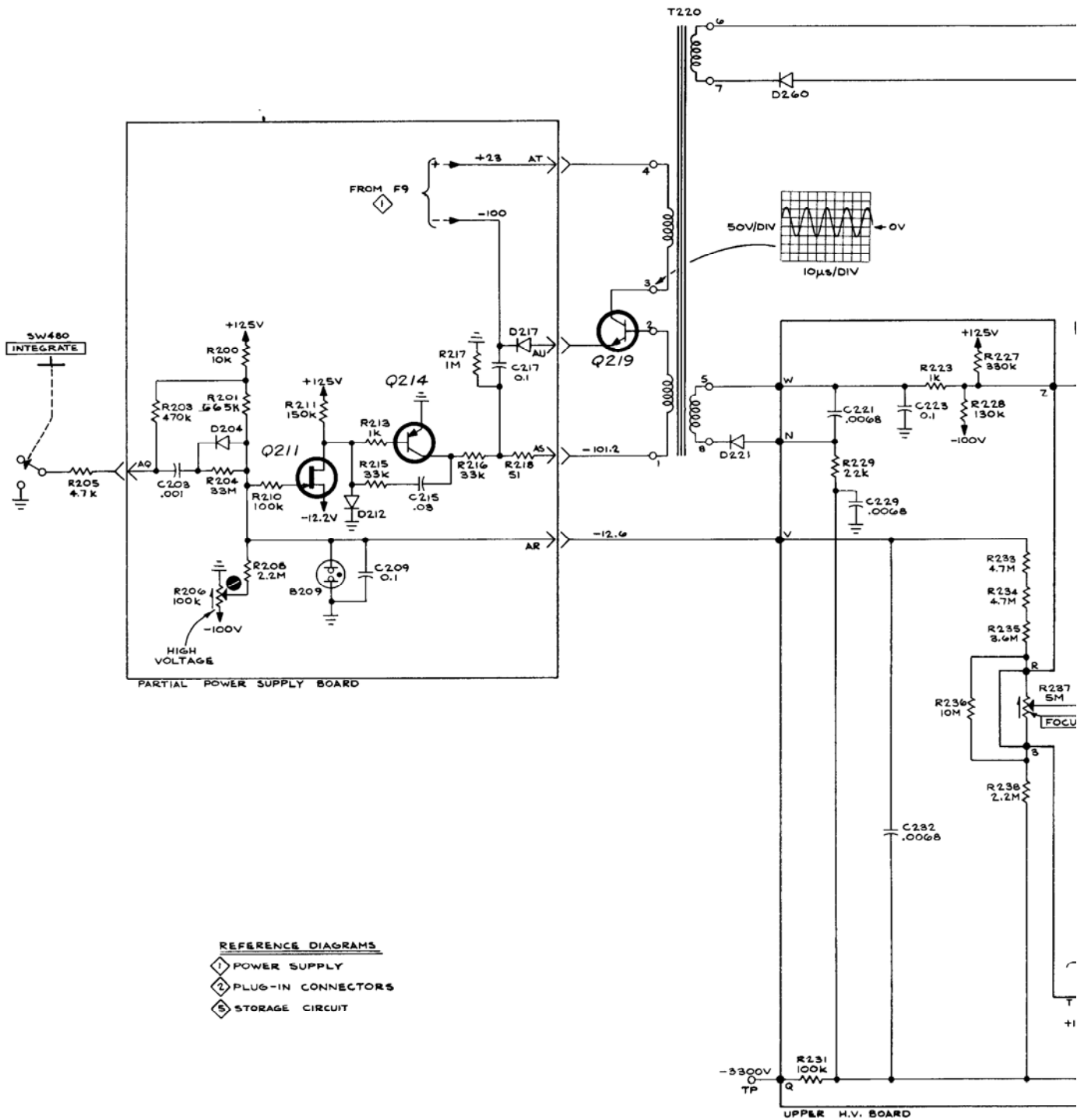

TYPE R564B

+

SEE SEM

b

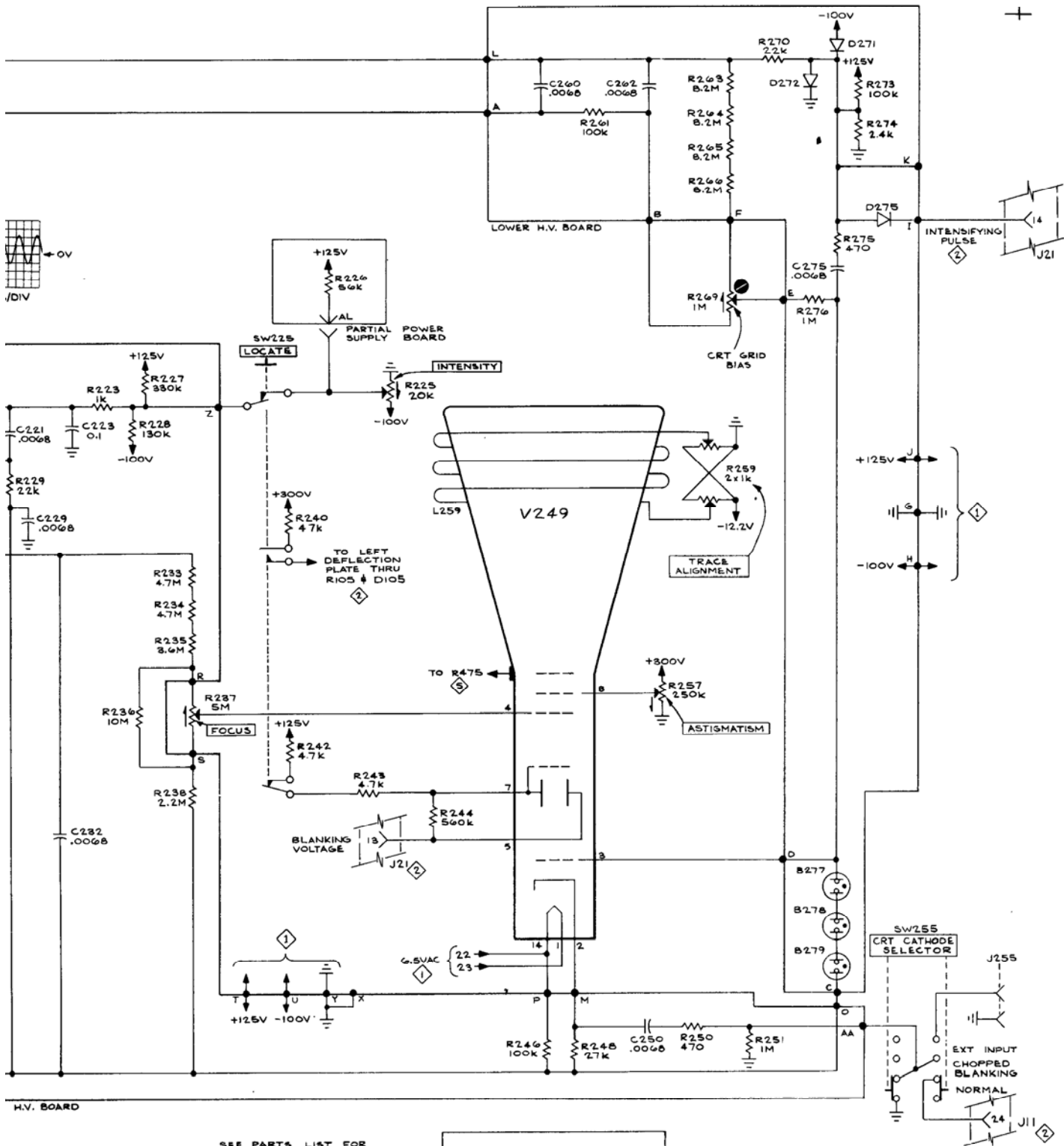

SEE PARTS LIST FOR SEMICONDUCTOR TYPES

VOLTAGES and WAVEFORMS obtained under conditions given on Diagram

CRT CIRCUIT 769



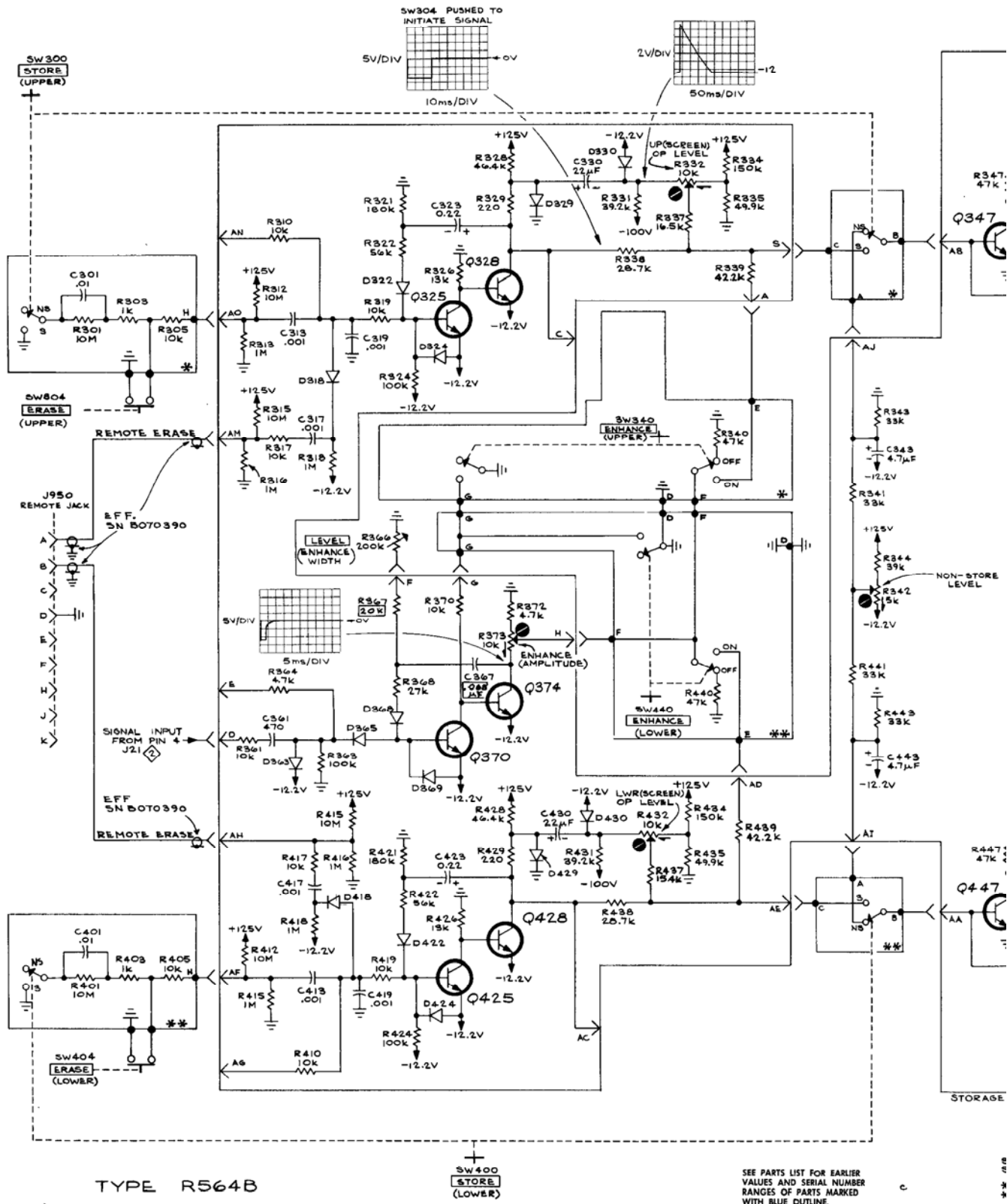

VOI  
con

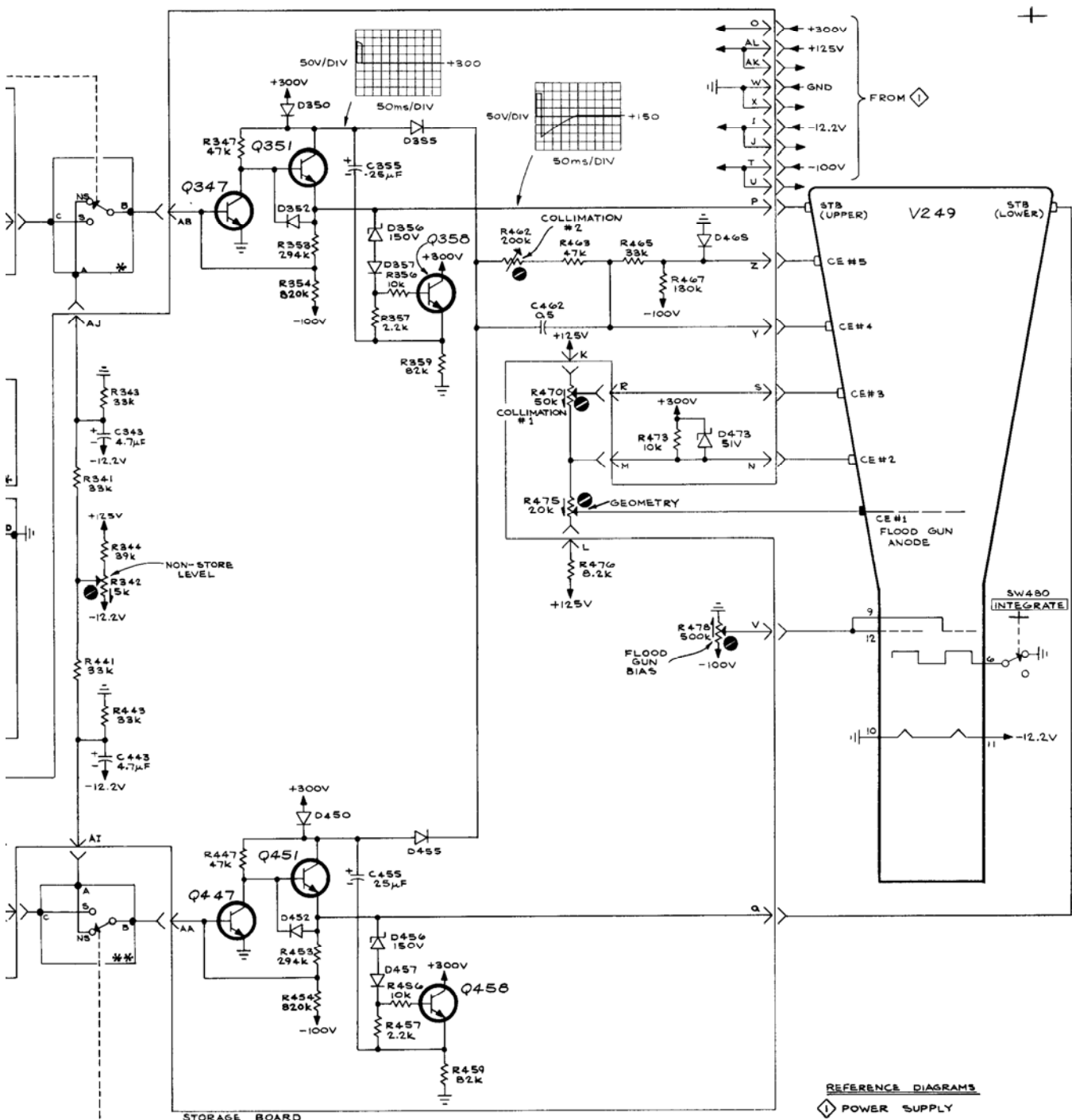

REFERENCE DIAGRAMS  
 ① POWER SUPPLY  
 ② PLUG-IN CONNECTORS

SEE PARTS LIST FOR SEMICONDUCTOR TYPES  
 \* DENOTES UPPER SWITCH INTERFACE  
 \*\* DENOTES LOWER SWITCH INTERFACE

VOLTAGES and WAVEFORMS obtained under conditions given on Diagram ①

669  
 STORAGE CIRCUIT ⑤

IS LIST FOR EARLIER AND SERIAL NUMBER OF PARTS MARKED IF OUTLINE.

FIG. 1 FRONT

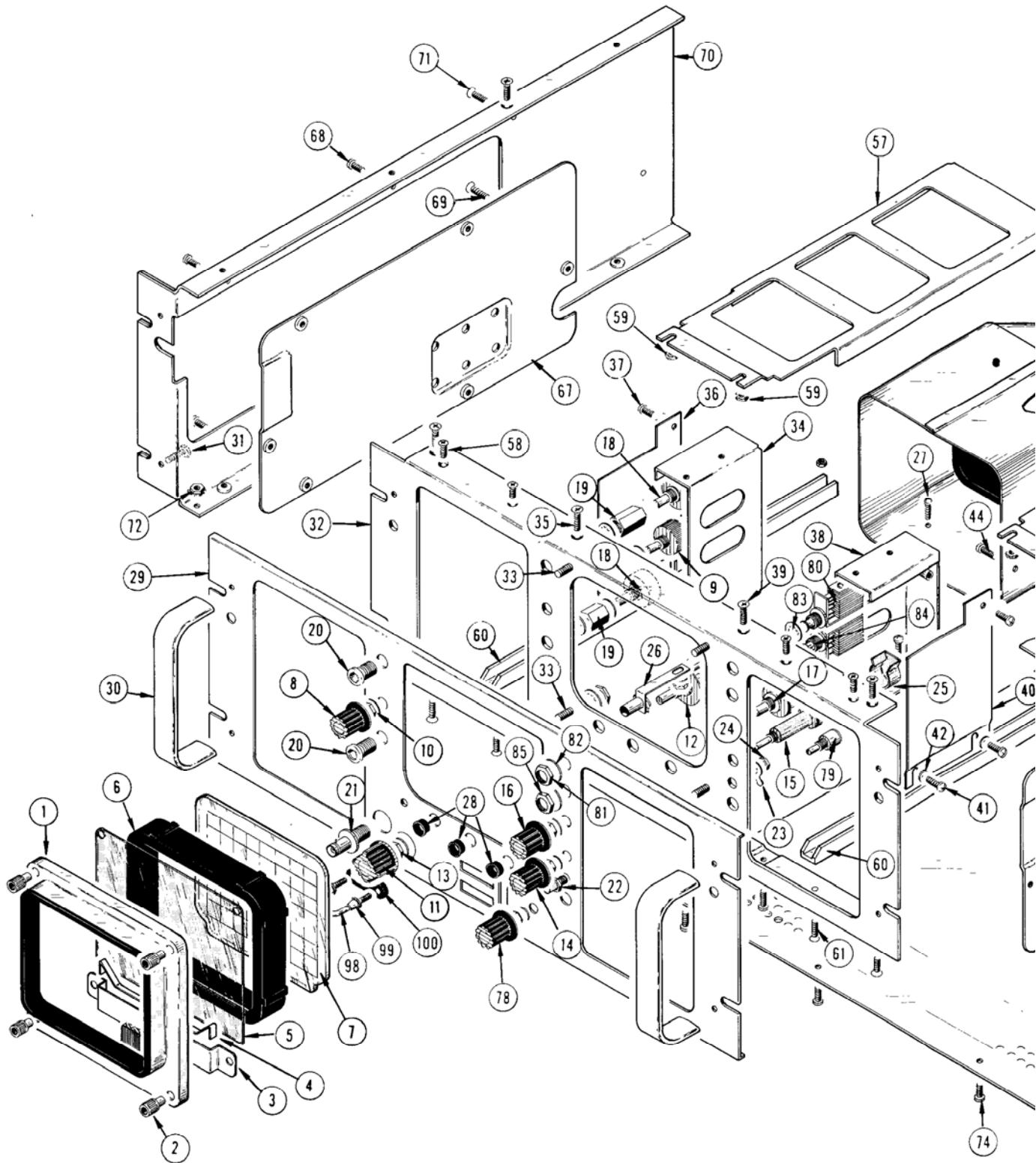

+ A

FIG. 1 FRONT

+

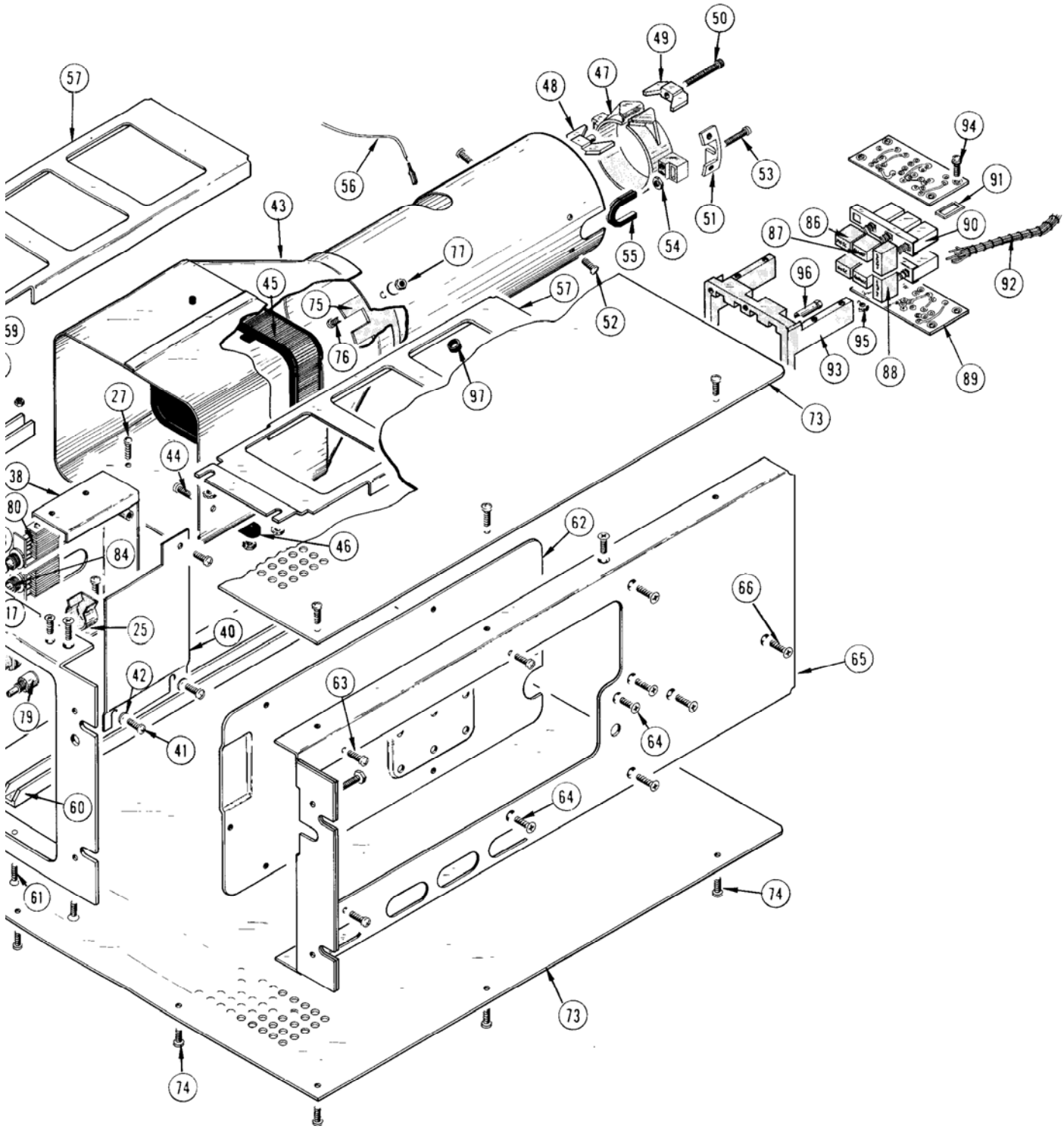

FIG. 2 REAR

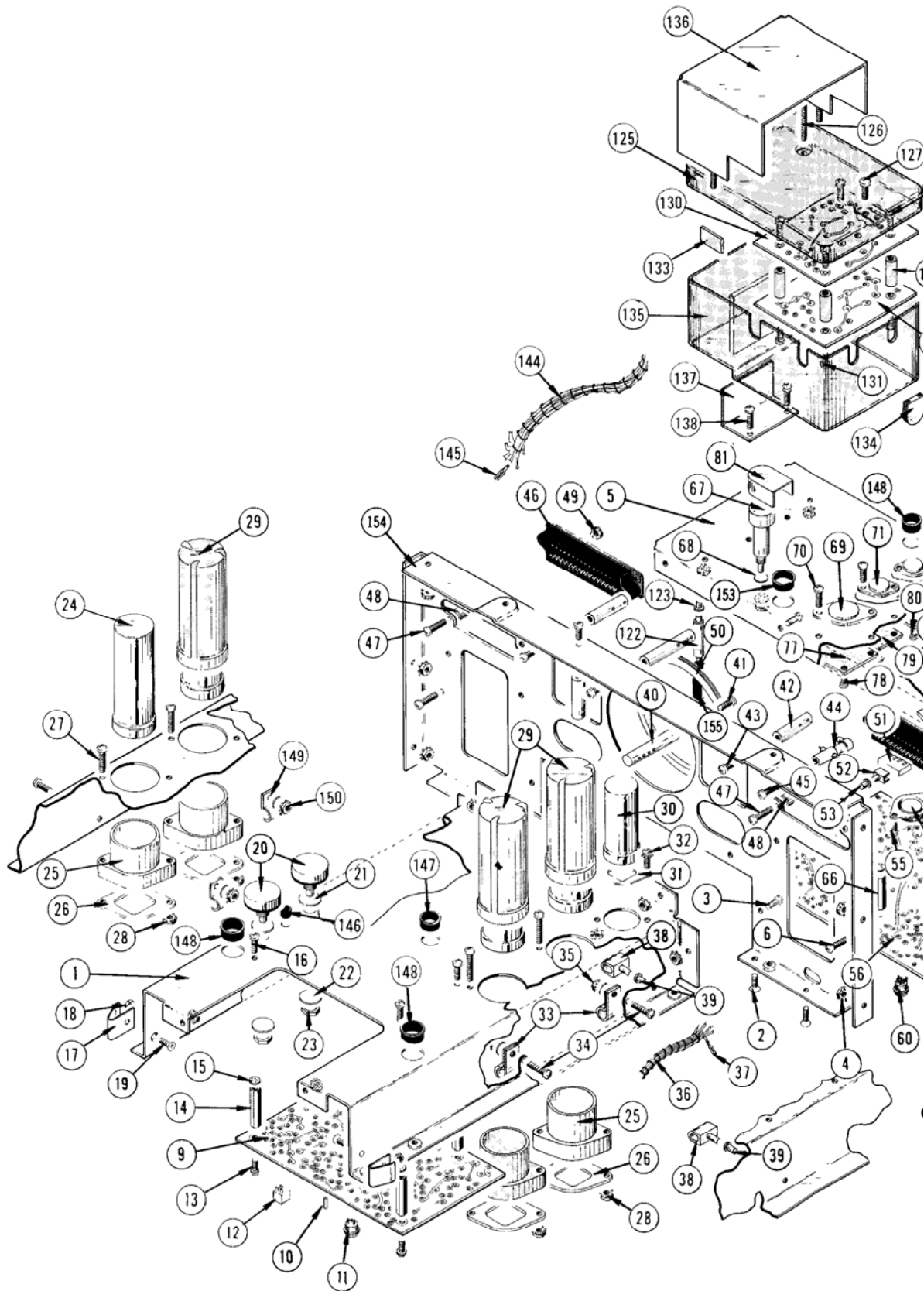
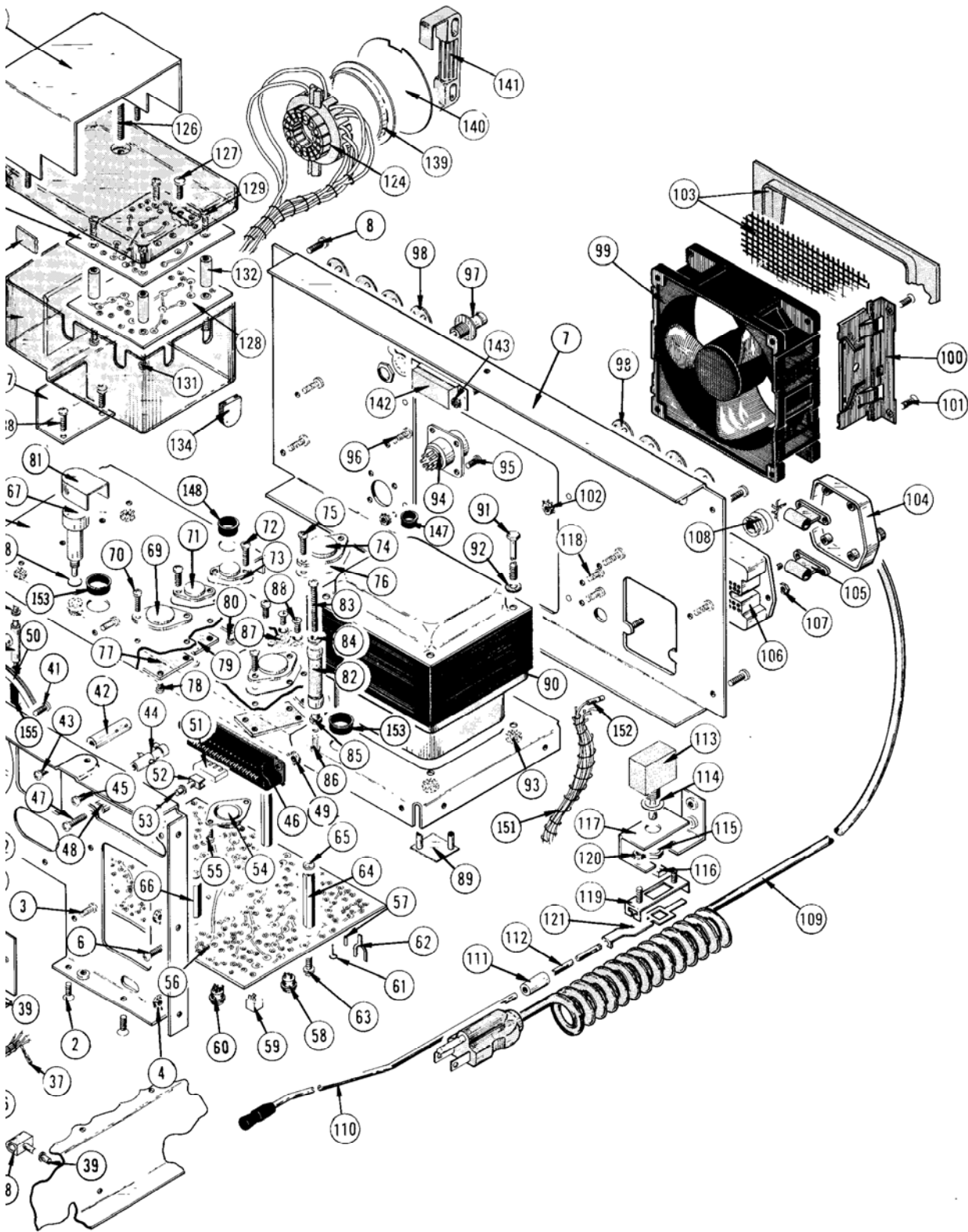

FIG. 2 REAR

+



MECHANICAL PARTS LIST—TYPE R564B

FIG. 3 STANDARD ACCESSORIES

+

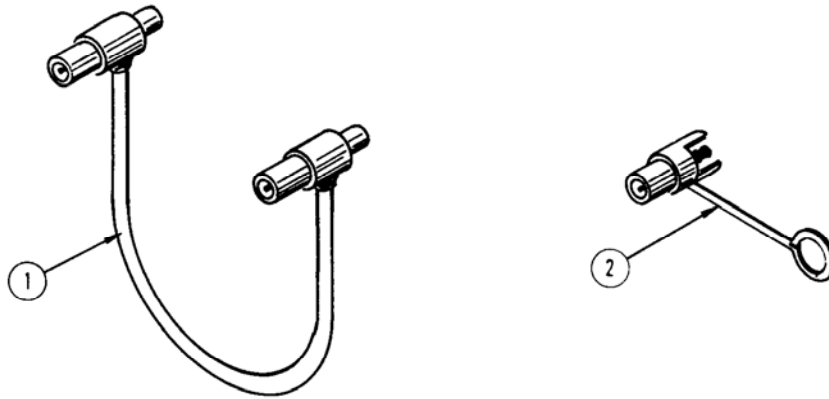

+A

FIG. 3 ACCESSORIES

Fig. & Index No.	Tektronix Part No.	Serial/Model Eff	No. Disc	Q					Description	
				t	y	1	2	3		4
3-1	012-0087-00			1						CORD, patch
-2	012-0092-00			1						JACK, BNC-post
	016-0131-00			1						HARDWARE KIT (not shown)
	070-0805-00			2						MANUAL, instruction (not shown)

## **MANUAL CHANGE INFORMATION**

At Tektronix, we continually strive to keep up with latest electronic developments by adding circuit and component improvements to our instruments as soon as they are developed and tested.

Sometimes, due to printing and shipping requirements, we can't get these changes immediately into printed manuals. Hence, your manual may contain new change information on following pages.

A single change may affect several sections. Sections of the manual are often printed at different times, so some of the information on the change pages may already be in your manual. Since the change information sheets are carried in the manual until ALL changes are permanently entered, some duplication may occur. If no such change pages appear in this section, your manual is correct as printed.



Type 561B, R561B

Type 564B, R564B

### Illustration Correction

Reference to Upper High Voltage circuit board, 561B, Fig. 4-5,  
R561B, Fig. 4-6,  
564B, Fig. 4-8,  
R564B, Fig. 4-9,

Change "C283" to read "C223."

Reference to Lower High Voltage circuit board, 561B, Fig. 4-6,  
R561B, Fig. 4-7,  
564B, Fig. 4-9,  
R564B, Fig. 4-10,

Add R273 and R274 as shown in accompanying illustration:

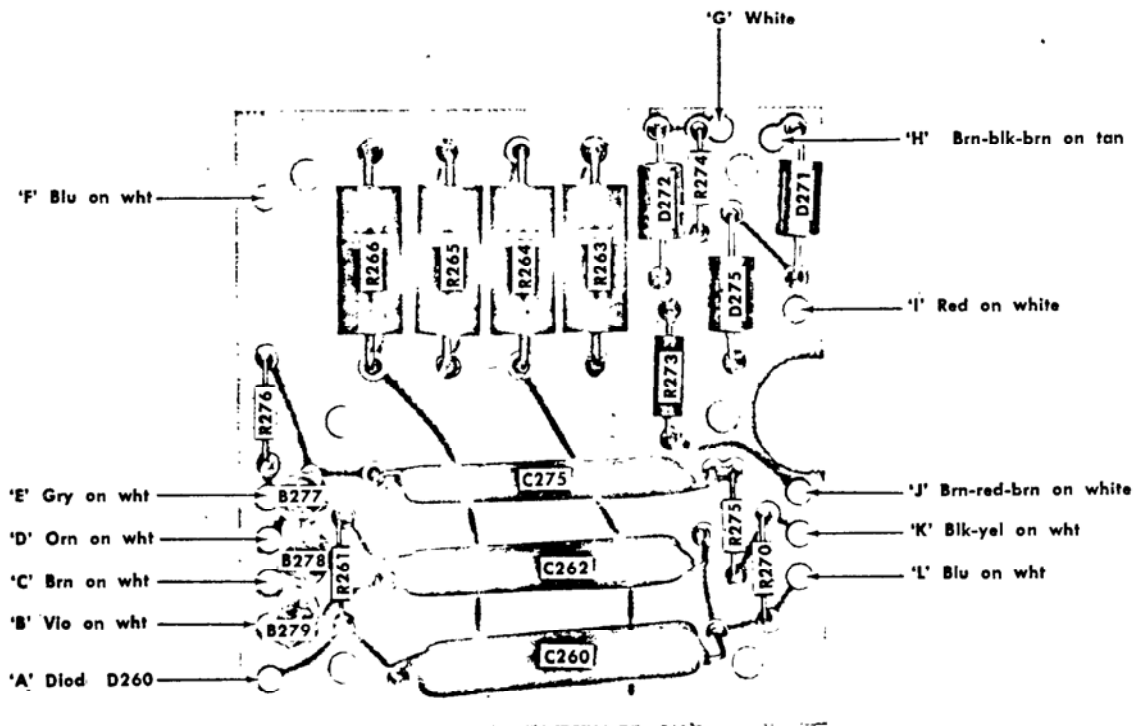

TYPE R564B

TEXT CORRECTION

Section 5            Calibration

Page 5-6            Step 6

CHANGE: Step 6 to read as follows:

6. Adjust CRT Grid Bias

a. Set the time-base Normal-Single Sweep switch to Normal and rotate the INTENSITY control clockwise until a trace can be seen.

b. Position the start of the sweep to the left edge of the graticule and adjust the FOCUS control for a well-defined trace.

c. Rotate the INTENSITY control fully counterclockwise.

d. Set the time-base Normal-Single Sweep switch to Single Sweep and rotate R269, CRT Grid Bias (Fig. 5-4), counterclockwise.

e. Press the LOCATE button and hold it in while performing the next step.

f. ADJUST--R269, CRT Grid Bias, clockwise until a low-intensity spot appears to the left of the sweep start in the locate zone. (It is best to view the CRT trace under low ambient light conditions or by using a viewing hood.)

g. With the LOCATE button still depressed, rotate the INTENSITY control throughout its range and note that it has no effect on the spot brilliance.

h. Rotate the INTENSITY control fully counterclockwise and release the LOCATE button.

Page 5-13            Step 17 A

DELETE: the note after step d, which says to clip a wire jumper around R167 to increase the drive to the Capacitance Normalizer.

C4/1168

TYPE R564B

TENT SN B060360

ELECTRICAL PARTS LIST CORRECTION

CHANGE :

R101

308-0021-00

4.5 k $\Omega$

10 W

WW

5%

SCHEMATIC CORRECTION

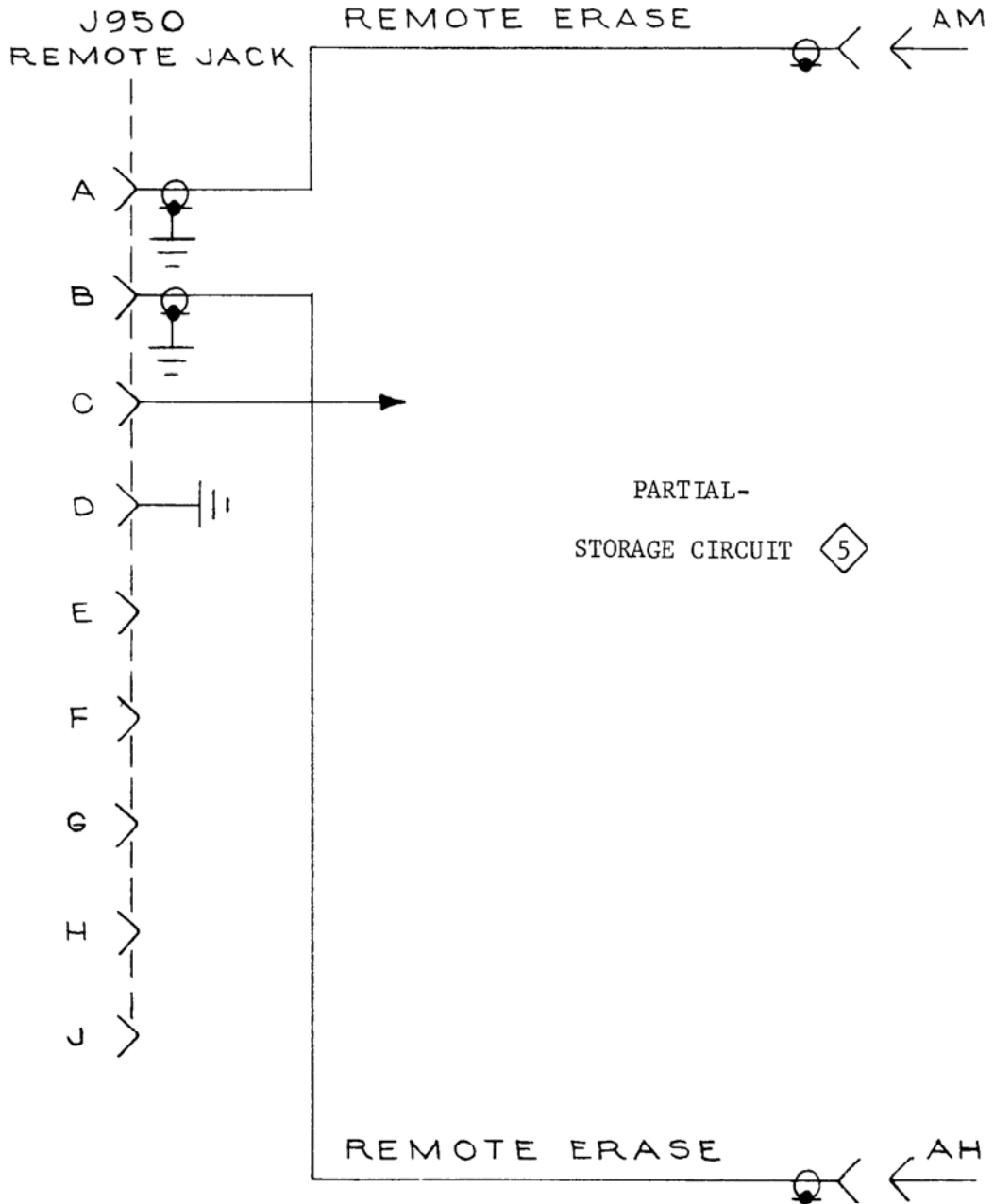

TYPE R564B    TENT SN B090740

ELECTRICAL PARTS LIST AND SCHEMATIC ADDITION

ADD:

C475	283-0002-00	0.01 $\mu$ F	Cer	500 V
------	-------------	--------------	-----	-------

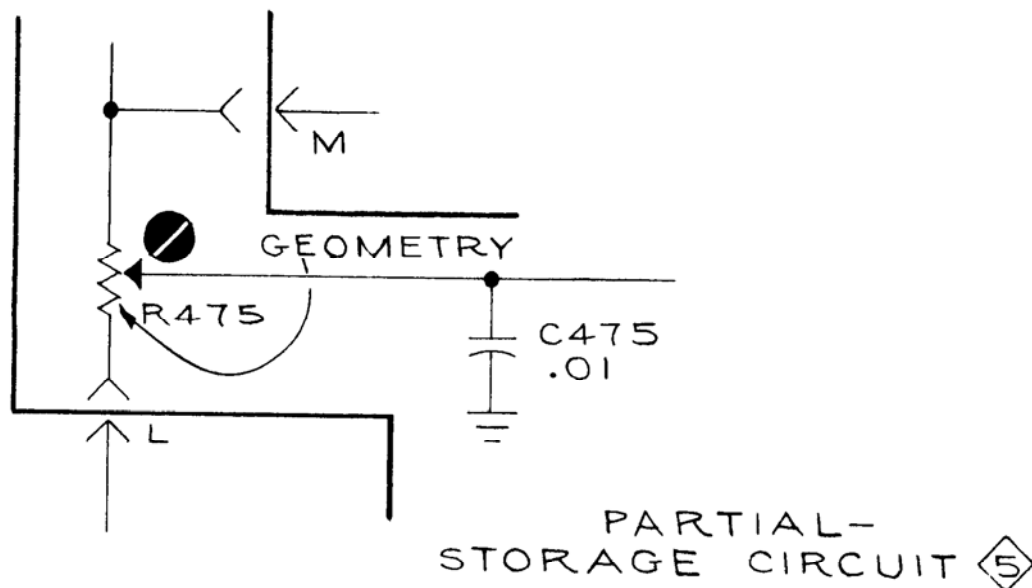

TYPE R564B

SCHEMATIC CORRECTION

PLUG-IN CONNECTORS 

DELETE: the \* on pin 9 of J11 and J21.

Pin 9 is now grounded near J11 and J21.